



DO NOT

**RETURN THIS
PRODUCT TO
THE RETAIL STORE**

**For assistance or warranty information,
please contact us at: 1-800-779-2102
Office hours are 8am to 5pm CST**



Dee Zee Running Board Installation Instructions

Congratulations on your purchase of a quality Dee Zee product. Dee Zee is recognized as having the highest quality running boards and accessories on the market today. We have earned this reputation by offering our customers a product they can be proud to place on their vehicles. Dee Zee meets all the criteria of manufacturing a custom-fit product which guarantees it to be the easiest product to install.

Note: Please take time to read all of the instructions before beginning this installation.

Cleaning instructions: To maintain the bright finish of your Dee Zee Running Board, clean with a mild detergent and use a high grade automotive type wax. **DO NOT USE ABRASIVE CLEANERS ON THIS PRODUCT!**









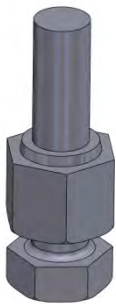
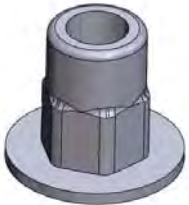

If you should happen to have any questions with this product or you have an installation question, please feel free to call us at:

1-800-779-8222

If you would like to find out more information on Dee Zee's products, please feel free to visit our website at:

WWW.DEEZEE.COM

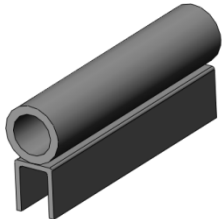
**DZ 3027 / DZ 3028 / DZ 3029 / DZ 3030
(2009-Current) Dodge Ram All cab styles**

<p>A Running Board</p>  <p>Various 1LH / 1RH</p>	<p>B Mounting Bracket</p>  <p>B 1711P X6 REG X4</p>	<p>C Install tool</p>  <p>PN 685 X1</p>
<p>D M8 nut insert</p>  <p>PN 686 X12 REG X8</p>	<p>E 8mm X 25mm Flange Head Bolt</p>  <p>PN 525-CHY X12 REG X8</p>	<p>F 1/4" Carriage Bolt</p>  <p>PN 87 X12 REG X8</p>
<p>G Mud flap</p>  <p>FP0311 / FP0312 X1 of Each</p>	<p>H 1/4" Hex head bolt</p>  <p>PN 70 X4</p>	<p>I 1/4" Flange Nut</p>  <p>PN 178 X16 REG X12</p>
<p>J Bulb Seal Gasket</p>  <p>GSK-41 Various</p>	<p>K 1/4" Sheet metal screw</p>  <p>PN 97 X4</p>	<p>L 1/4" Washer</p>  <p>PN 72 X16 REG X12</p>

Tools Required

Ratchet / Wrench
10mm / 15mm / 13mm
7/16" 3/8"
Drill
1/4" drill bit
3/16" drill bit

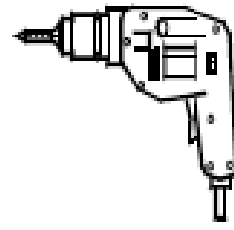
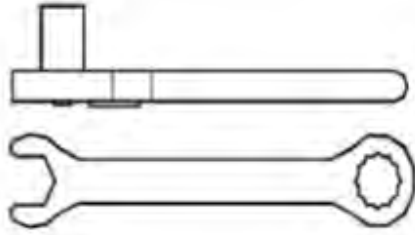

1

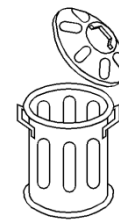
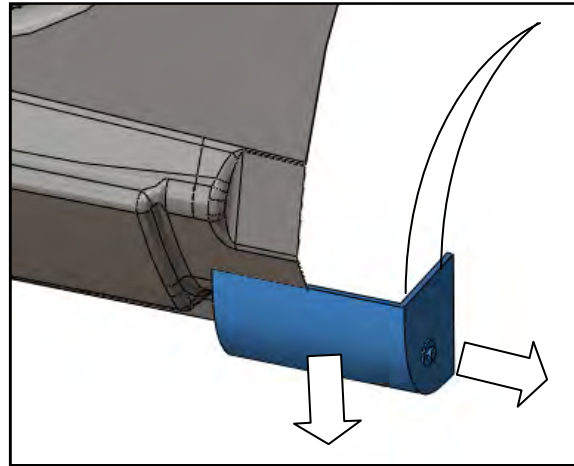

8mm Socket
Wrench

2

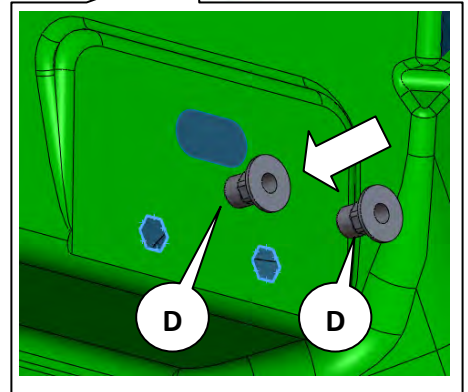
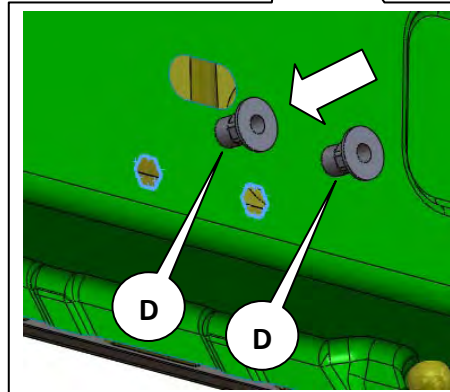
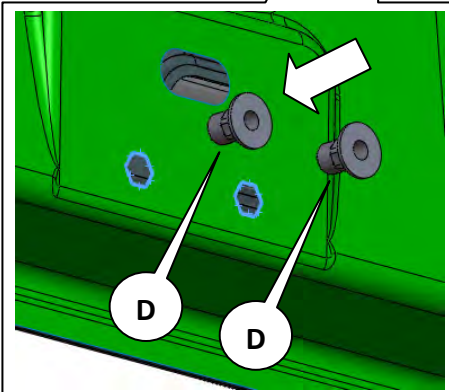
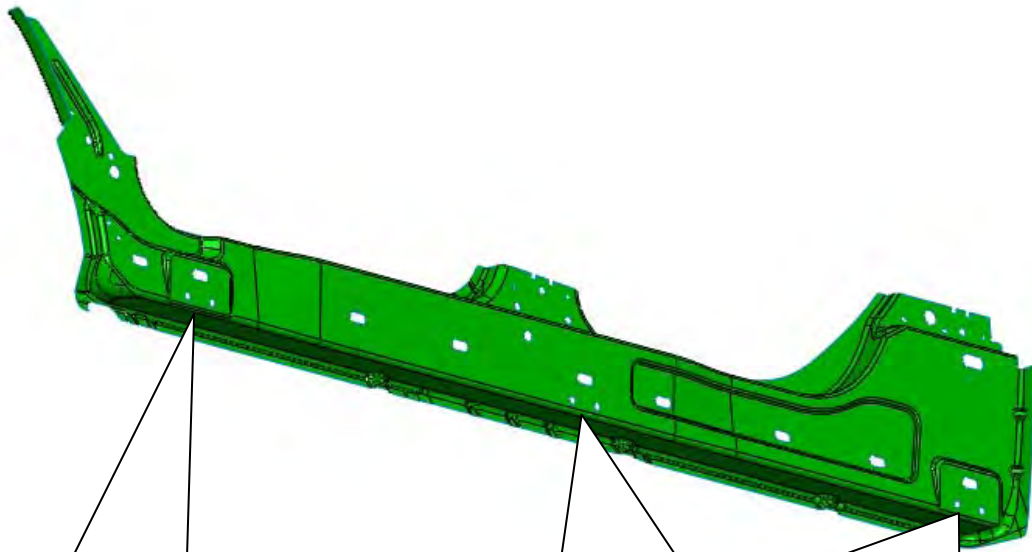

3

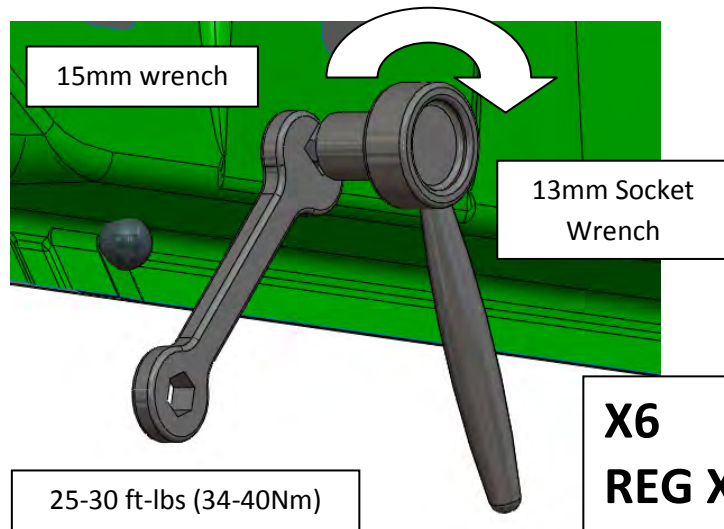
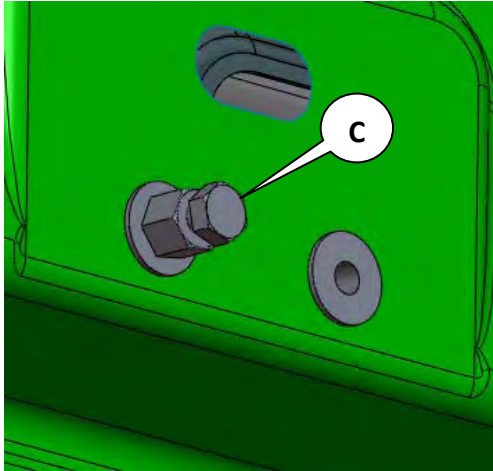

**X6
REG X4**

4

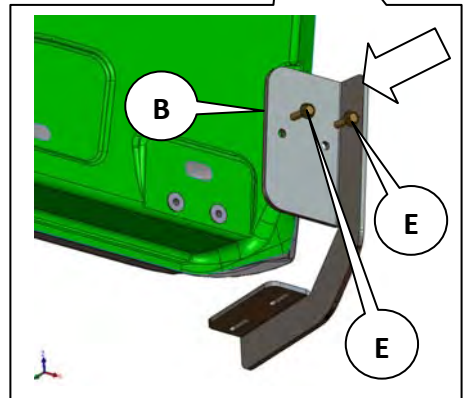
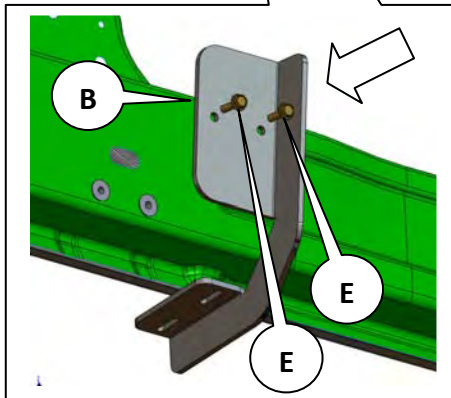
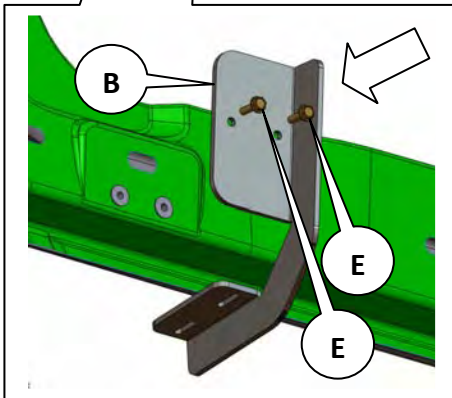
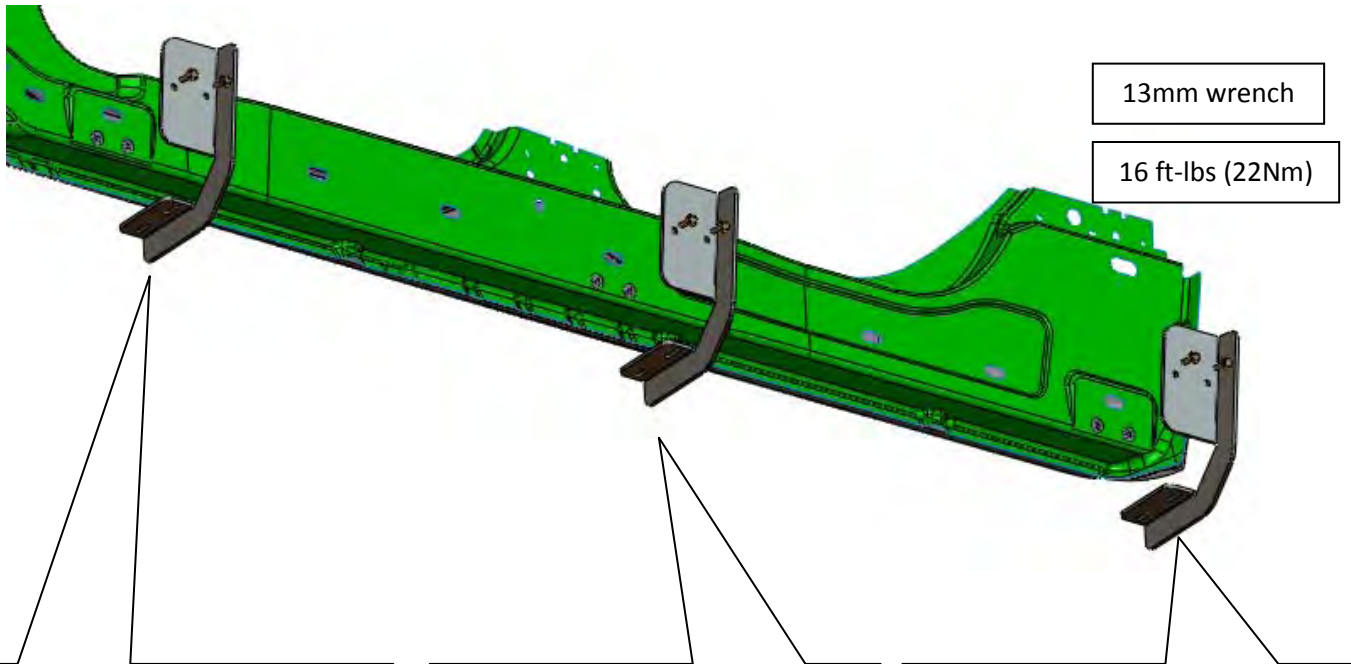

5

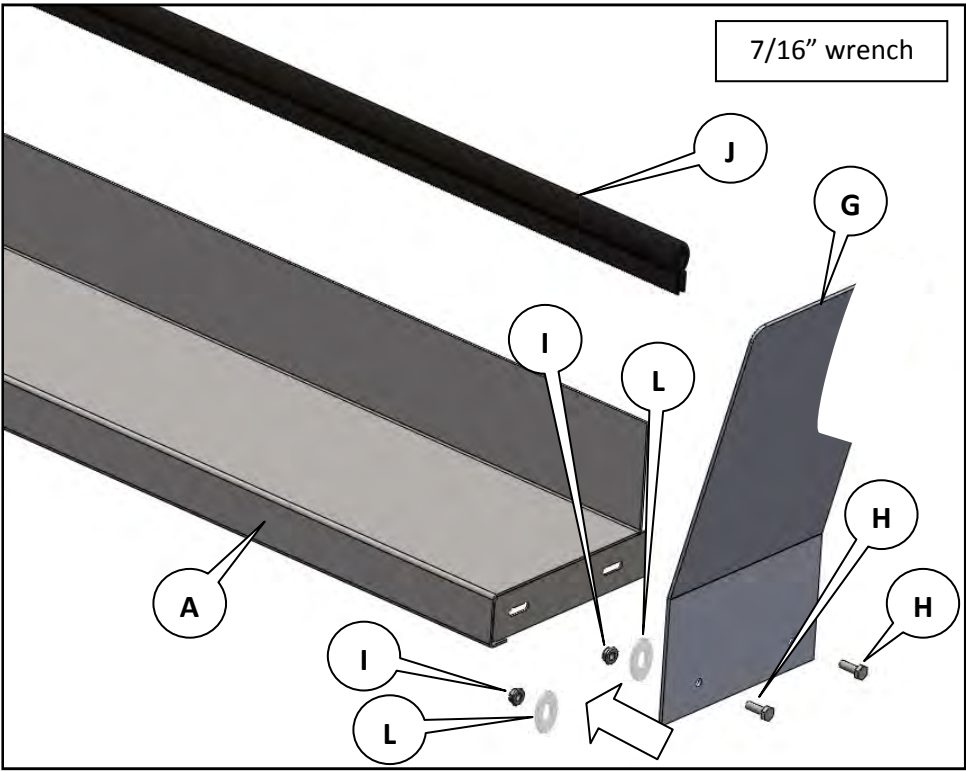

6

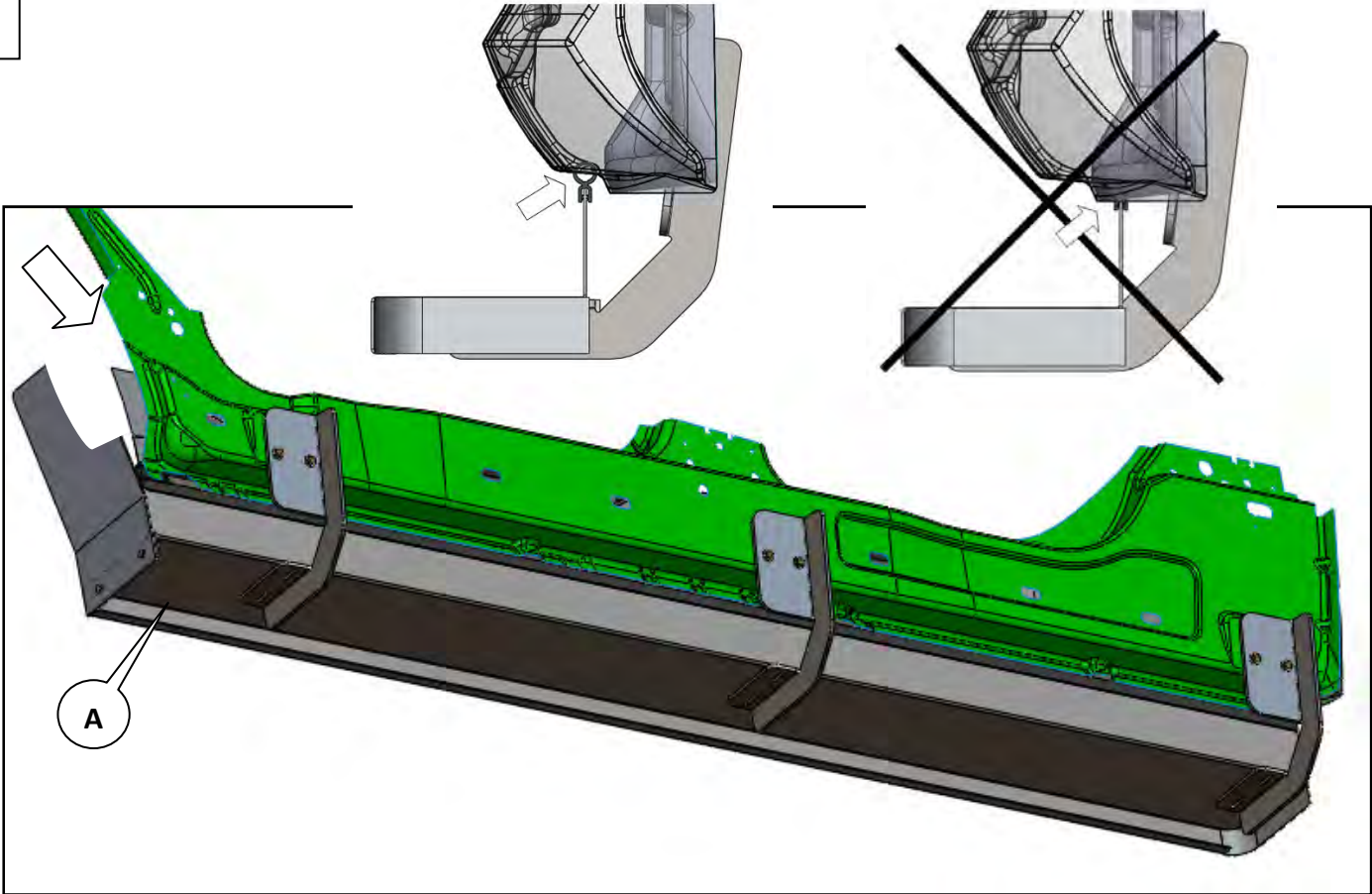

7

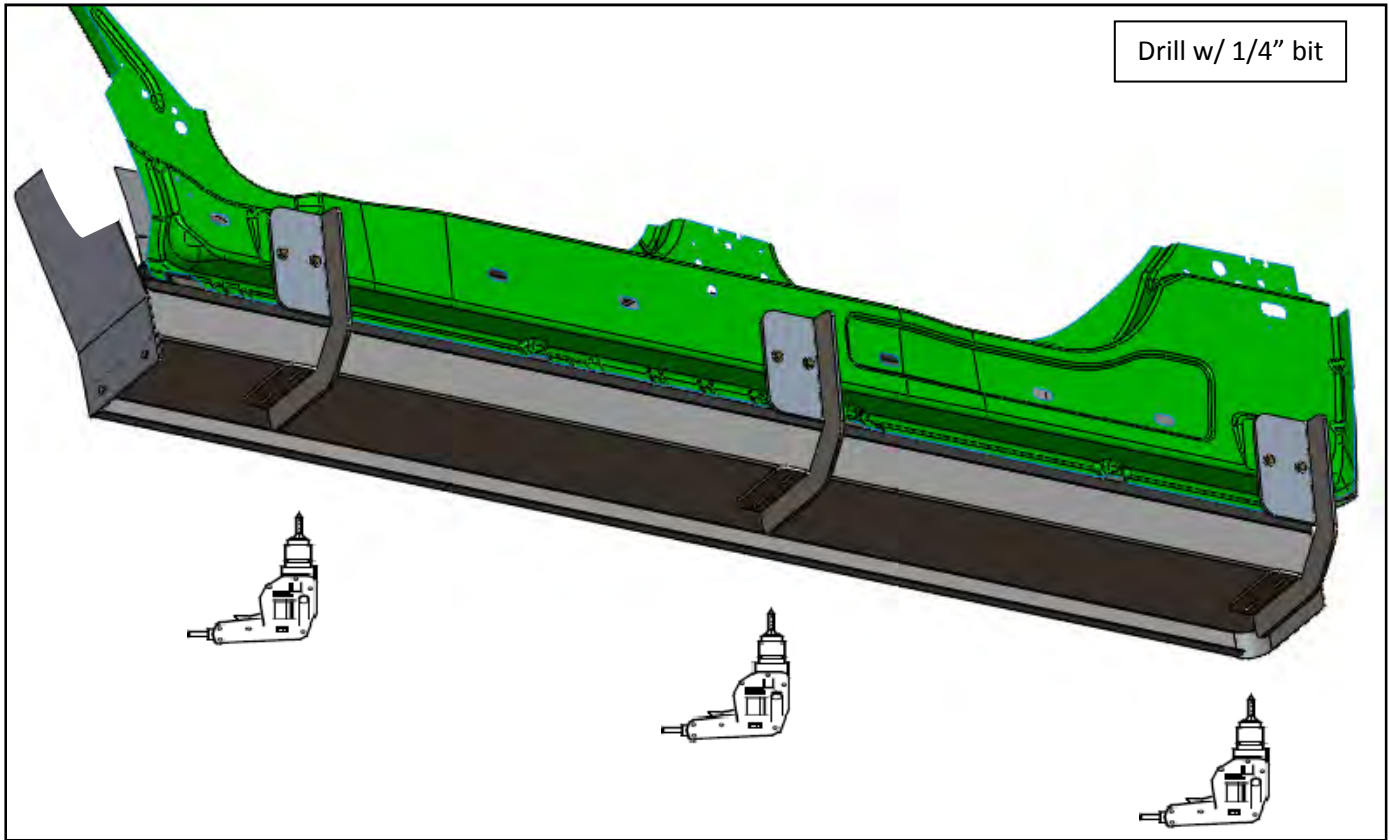

8

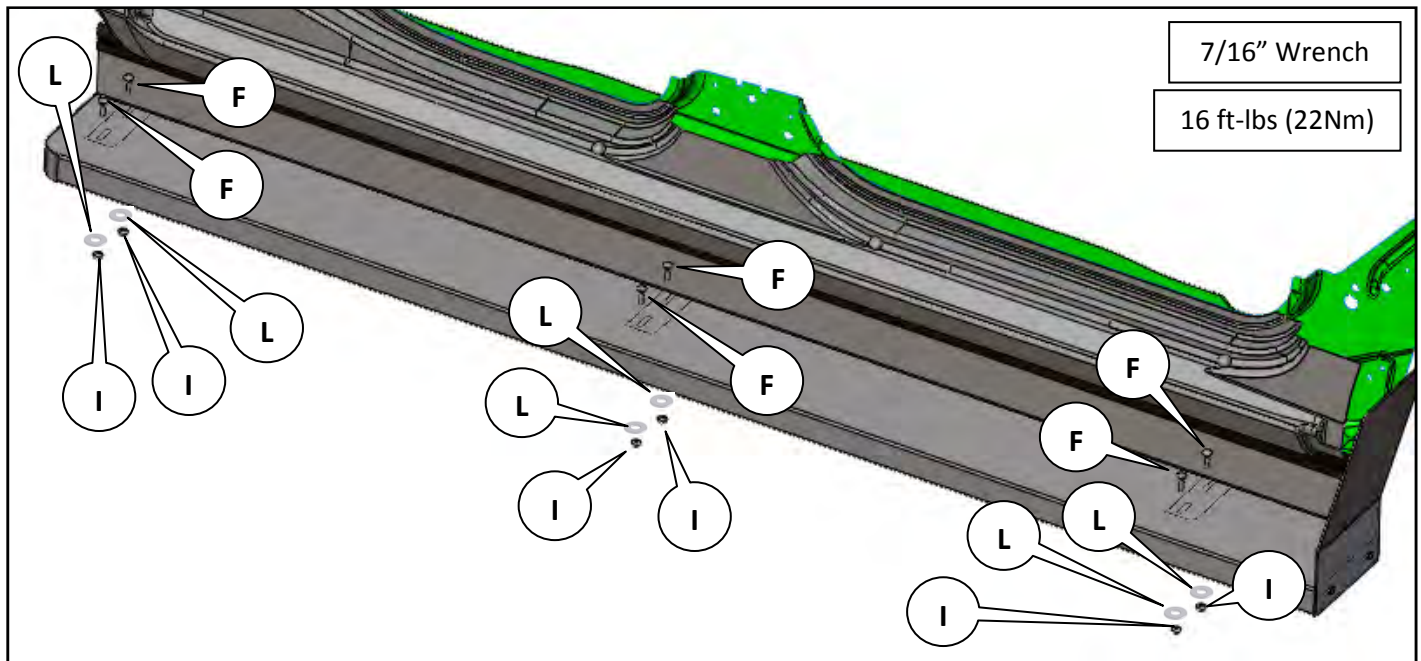

9

