



**Before returning this product
to the store of purchase**

Contact Dee Zee if you experience the following problems:

- Missing Parts
- Installation Problems/Questions
- Warranty Questions

1.800.779.2102

Hours of operation: 8am - 5pm CST, Mon-Friday

Review complete warranty policy and register your product at:

www.deezee.com



Dee Zee Running Board Installation Instructions

Congratulations on your purchase of a quality Dee Zee product. Dee Zee is recognized as having the highest quality running boards and accessories on the market today. We have earned this reputation by offering our customers a product they can be proud to place on their vehicles. Dee Zee meets all the criteria of manufacturing a custom-fit product which guarantees it to be the easiest product to install.

Note: Please take time to read all of the instructions before beginning this installation.

Cleaning instructions: To maintain the finish of your Dee Zee Running Board, clean with a mild detergent and use a high grade automotive type wax. **DO NOT USE ABRASIVE CLEANERS ON THIS PRODUCT!**







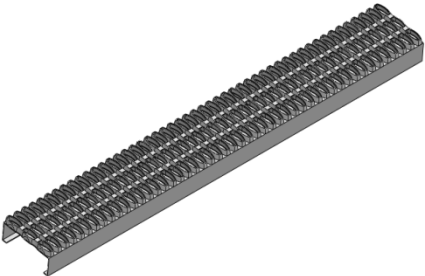
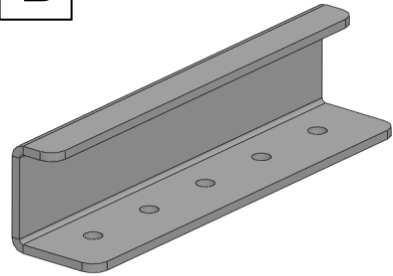

If you should happen to have any questions with this product or you have an installation question, please feel free to call us at:

1-800-779-8222

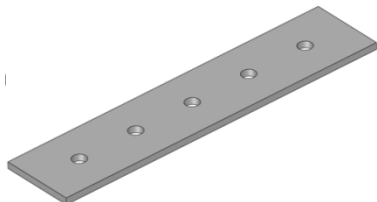
If you would like to find out more information on Dee Zee's products, please feel free to visit our website at:

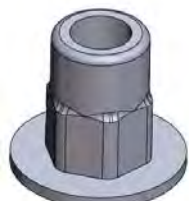
WWW.DEEZEE.COM

DZ 3527 / DZ 3528 / DZ 3530
(2009-Current) Dodge Ram Regular, Quad, & Crew cab styles

<p>A Running Board</p>  <p>Various</p>	<p>B End Caps</p>  <p>2X EC RSP</p>	<p>C Angle Bracket</p>  <p>X4 B 1792P X4-Regular cab X6-Crew & Super cabs</p>
<p>D Strap bracket</p>  <p>B 1791P X8-Regular cab X10-Crew & Super cabs</p>	<p>E Mounting Bracket</p>  <p>B 1711P X4-Regular cab X6-Crew & Super cabs</p>	<p>F Install tool</p>  <p>PN 685 X2</p>
<p>G M8 Crimp nut</p>  <p>PN 686 X8-Regular cab X12-Crew & Super cabs</p>	<p>H M8 Bolt</p>  <p>PN 525-CHY X8-Regular cab X12-Crew & Super cabs</p>	<p>I 1/4" nut</p>  <p>PN 71B X20-Regular cab X26-Crew & Super cabs</p>
<p>J 1/4" bolt</p>  <p>PN 96B X20-Regular cab X26-Crew & Super cabs</p>	<p>K 1/4" washer</p>  <p>PN 72B X40-Regular cab X52-Crew & Super cabs</p>	

Tools Required

Ratchet / Wrench
13mm / 15mm / 7/16"

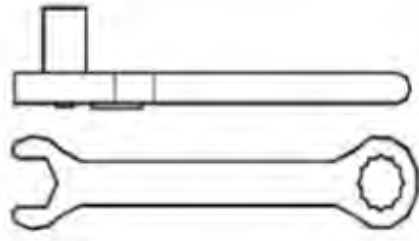

1

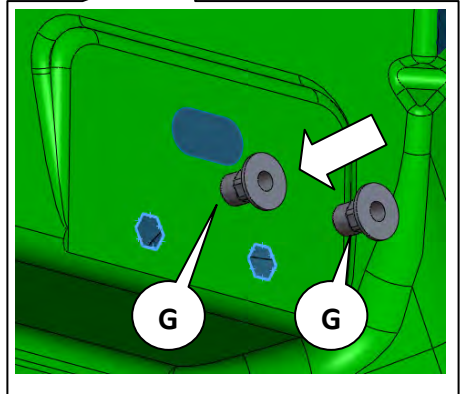
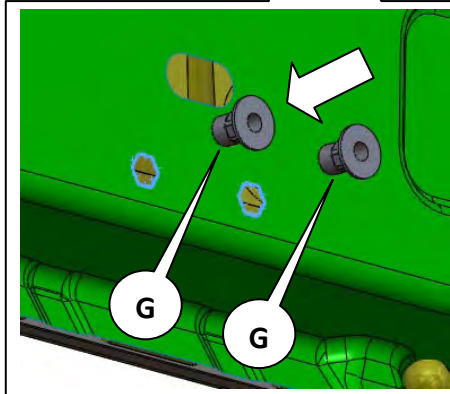
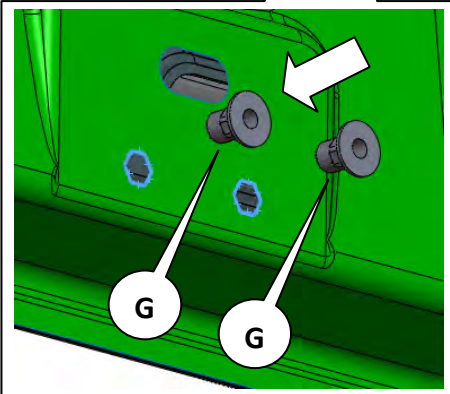
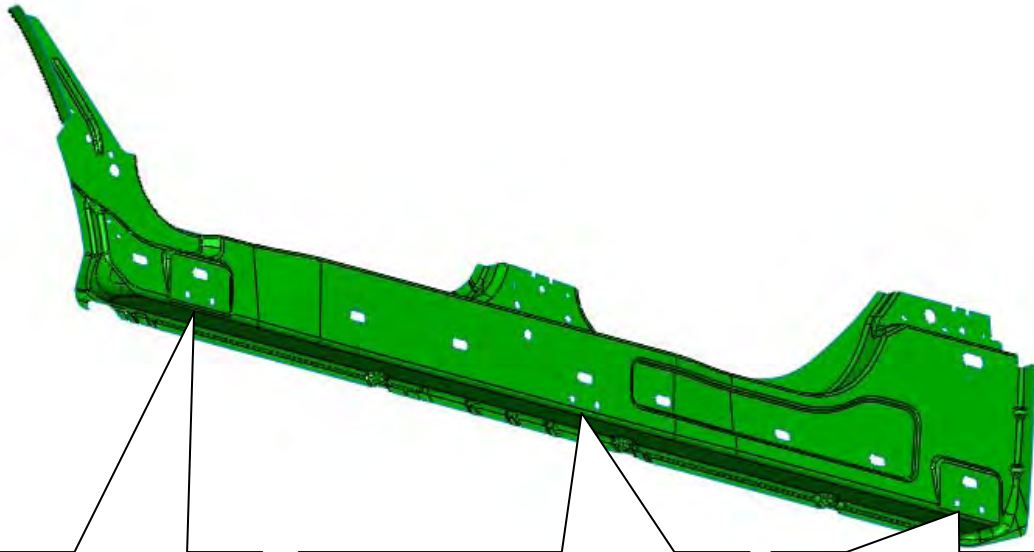

2

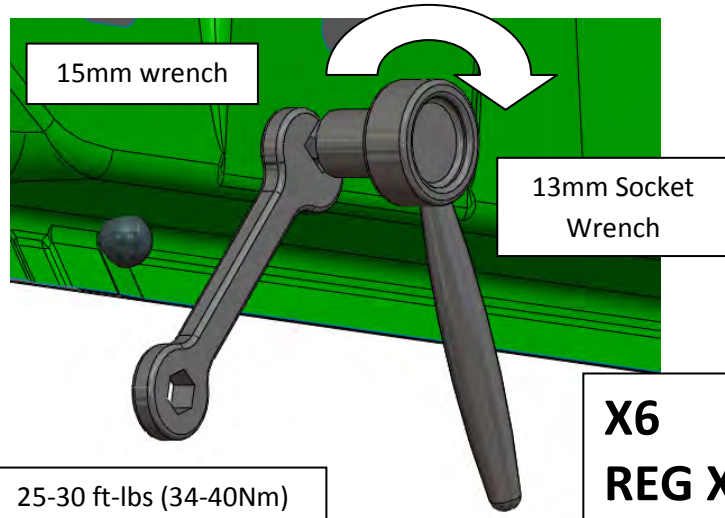
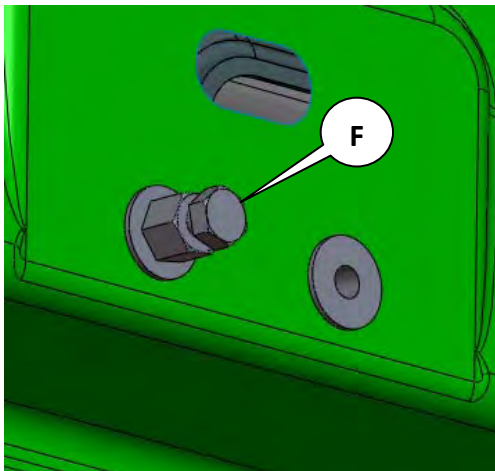

3

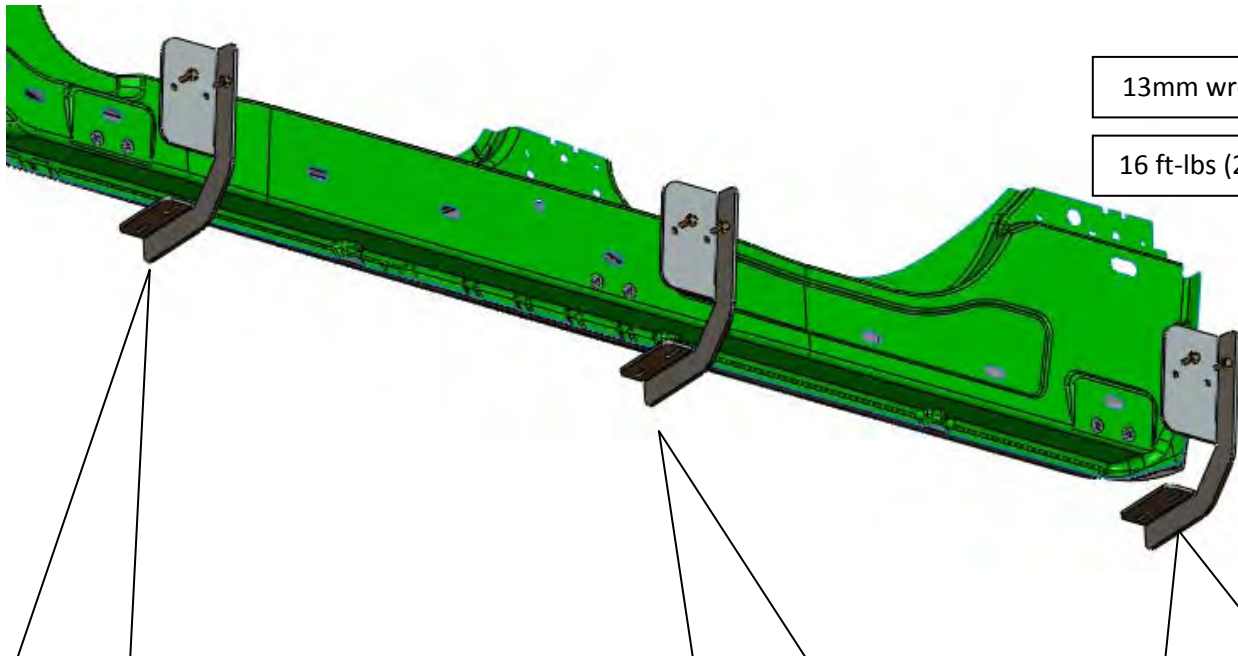

13mm wrench
16 ft-lbs (22Nm)

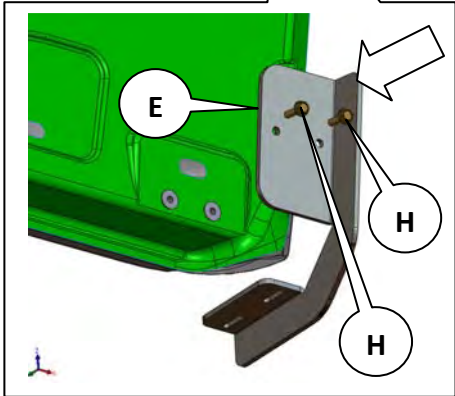
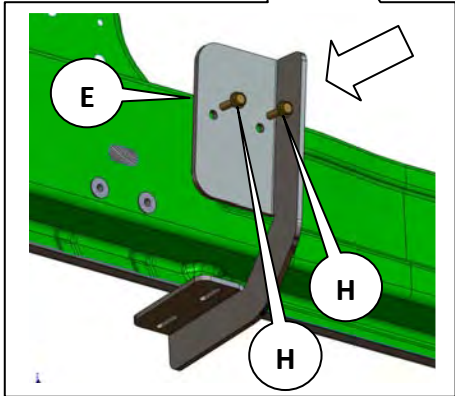
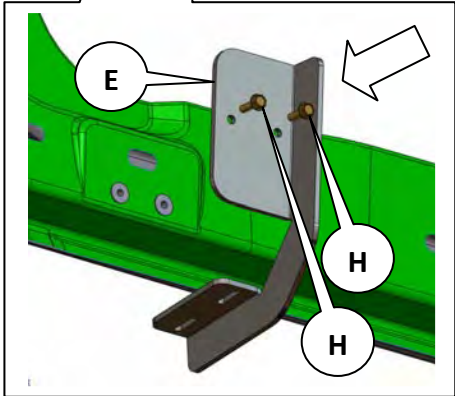

4

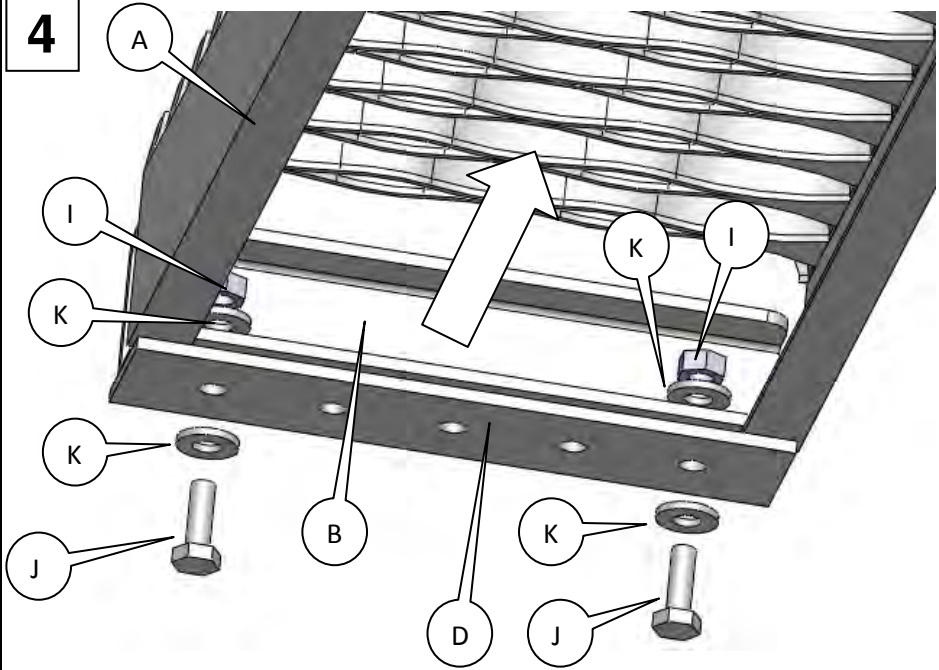

X4

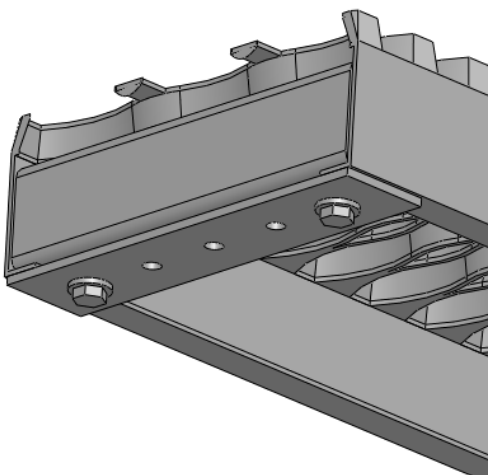

5

