



**Before returning this product
to the store of purchase**

Contact Dee Zee if you experience the following problems:

- Missing Parts
- Installation Problems/Questions
- Warranty Questions

1.800.779.2102

Hours of operation: 8am - 5pm CST, Mon-Friday

Review complete warranty policy and register your product at:

www.deezee.com/warranty.php

INSTALLATION INSTRUCTIONS

**3"& 4" 90DEG BENT END SIDEBARS
97-03, 04 HERITAGE FORD REGULAR CAB F150, F250 LIGHT DUTY
PART# DZ 370331/370332/370333**

PARTS LIST:

1	Driver/Left Sidebar	2	10mm Offset Double Bolt Plates (for front)
1	Passenger/Right Sidebar	2	10mm Double Bolt Plates (for rear)
1	Driver/Left Front Mounting Bracket	8	10mm ID x 27mm OD x 3mm Flat Washers
1	Passenger/Right Front Mounting Bracket	8	10mm Lock Washers
1	Driver/Left Rear Mounting Bracket	8	10mm Hex Nuts
1	Passenger/Right Rear Mounting Bracket	8	8mm x 25mm Hex Bolts
4	1/2" x 2" Hex Bolts	16	8mm x 24mm OD x 2mm Flat Washers
4	1/2" Lock Washers	8	8mm Lock Washers
4	1/2" ID x 1 1/2" OD x 1/8 Flat Washers	8	8mm Hex Nuts

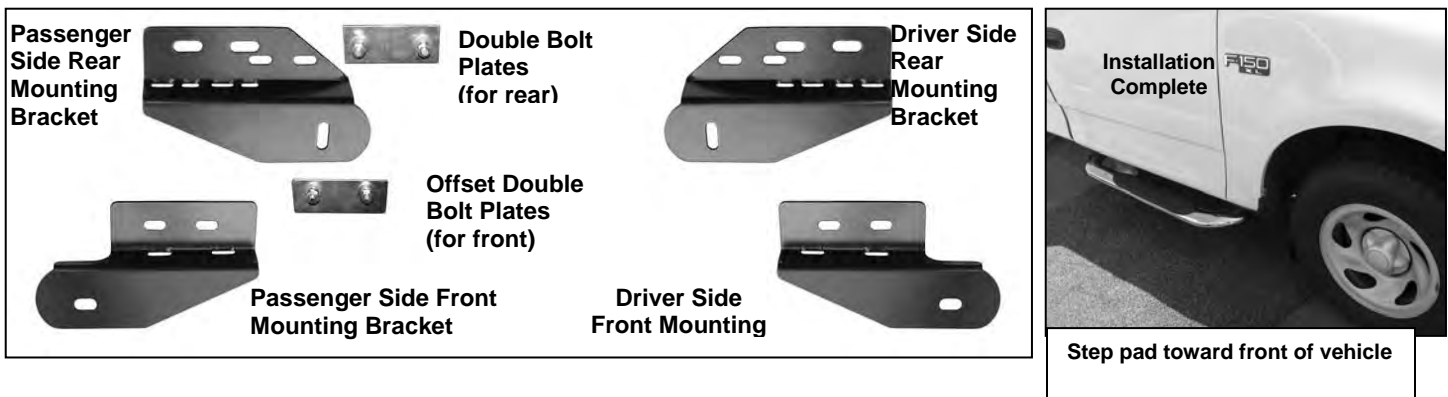

PROCEDURE:

- 1. REMOVE CONTENTS FROM BOX. VERIFY ALL PARTS ARE PRESENT. READ INSTRUCTIONS CAREFULLY BEFORE STARTING INSTALLATION.**
- From under the driver side front of the vehicle, remove the oval grommet located on the inside of the rocker panel, (**Figure 1**). Insert (1) Offset Double Bolt Plate, (with threaded studs toward the top), into the factory oval hole, (**Figure 2**).
- Locate the driver side front Mounting Bracket. Hold the Double Bolt Plate from one side while you position and attach the Mounting Bracket to the opposite side. Secure the Bolt Plate with one 10mm Flat Washer, 10mm Lock Washer and 10mm Hex Nut. Proceed to install the rest of the hardware to secure the Mounting Bracket to the Double Bolt Plate. (**Figure 3**). Do not tighten hardware at this time.
- Align the Mounting Bracket with holes in the pinch weld. Attach the Mounting Bracket to the pinch weld using the included (2) 8mm x 25mm Hex Bolts, (4) 8mm Flat Washers, (2) 8mm Lock Washers and (2) 8mm Hex Nuts. **NOTE:** Insert Bolt with Flat Washer from the outside-in. Do not tighten hardware at this time.
- Moving to the rear, use one of the (centered) Double Bolt Plates and hardware to install the Rear Bracket. Repeat steps 2 – 4 for driver side rear Mounting Bracket. Depending on model year, slots in rear Mounting Brackets may align with only one factory hole along pinch weld, (**Figure 4**). If desired, installer may drill through Pinch Weld for second Pinch Weld bolt, (included). **IMPORTANT:** Do not drill for second hole until the Sidebar has been completely installed and adjusted to properly locate the Mounting Bracket on the vehicle. Do not tighten hardware at this time.
- Once the Mounting Brackets have been partially installed, carefully unpack and separate the driver and passenger Sidebar. **NOTE:** Step pad typically goes toward front of vehicle to match

footwell. Position Sidebar onto Mounting Brackets using the included (2) 1/2" x 2" Hex Head Bolts, (2) 1/2" Lock Washers, and (2) 1/2" Flat Washers, **(Figure 4)**. Do not tighten hardware.

7. Level and adjust the Sidebar, drill for second Pinch Weld Bolt if necessary, then tighten all hardware at this time.
8. Repeat steps 2 – 7 for passenger Sidebar installation.
9. Do periodic inspections of the installation to make sure all hardware is secure and tight.

To protect your investment, wax this product after installing. Regular waxing is recommended to add a protective layer over the finish. Do not use any type of polish or wax that may contain abrasives that could damage the finish.

For stainless steel: Aluminum polish may be used to polish small scratches and scuffs on the finish. Mild soap may be used also to clean the Sidebar.

For gloss black finishes: Mild soap may be used to clean the Sidebar.

Driver Side Installation Pictured

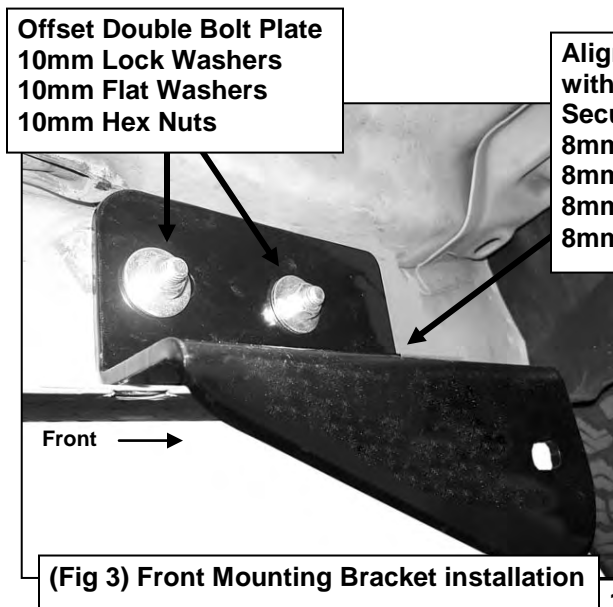
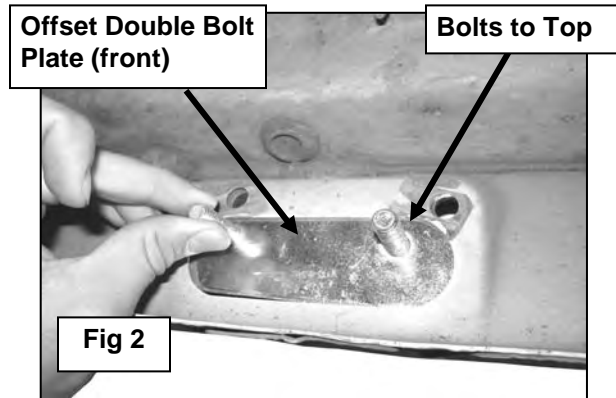
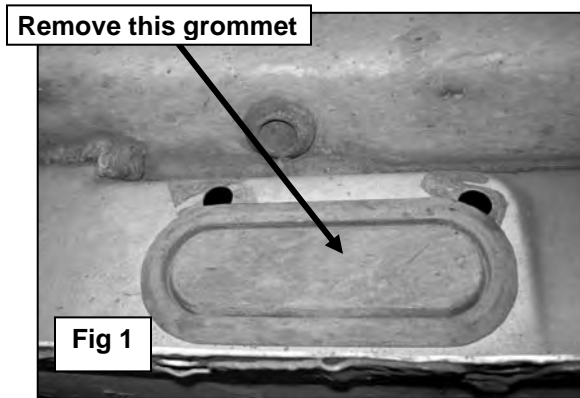

Align holes in brackets with holes in pinch weld. Secure with:
 8mm x 25mm Hex Bolts
 8mm Hex Nuts
 8mm Lock Washers
 8mm Flat Washers

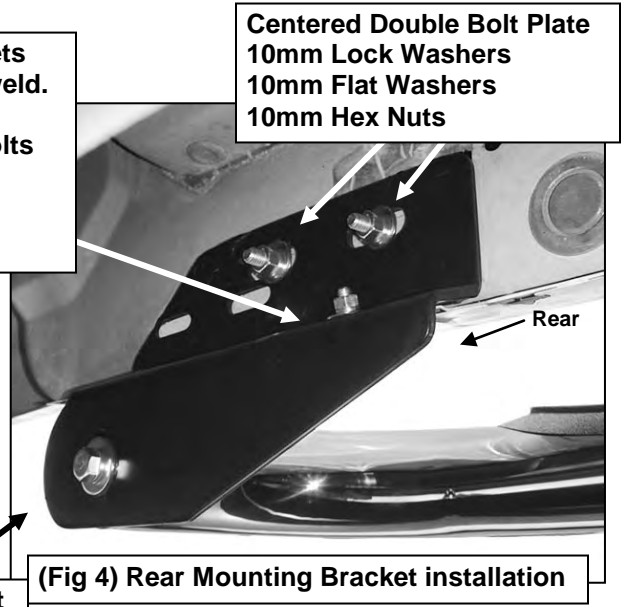

1/2" x 2" Hex Bolt
 1/2" Lock Washer
 1/2" Flat Washer