



**Before returning this product
to the store of purchase**

Contact Dee Zee if you experience the following problems:

- Missing Parts
- Installation Problems/Questions
- Warranty Questions

1.800.779.2102

Hours of operation: 8am - 5pm CST, Mon-Friday

Review complete warranty policy and register your product at:

www.deezee.com/warranty.php

Installation Instructions
SIDE BAR PART# DZ 371241/371242/371243
06 – 07 Dodge Ram Mega Cab

PARTS LIST

(2) SIDE TUBES WITH STEPS	(16) M12 FLAT WASHER
(2) FRONT MOUNT BRACKETS	(16) M12 LOCK WASHER
(2) REAR MOUNT BRACKETS	(16) M10 FLAT WASHERS
(2) FRONT BRACE BRACKETS	(16) M10 LOCK WASHERS
(2) CENTER BRACE BRACKETS	(12) M10 HEX NUTS
(4) M12 – 1.75 x 120mm HEX HEAD BOLT	(2) M12 FLAT WASHERS (50mm O.D.)
(4) M12X60mm HEX HEAD BOLT	
(2) M10X40mm HEX HEAD BOLT	
(2) M10x35mm HEX HEAD BOLT WITH METAL STRAP	
(2) M10X25mm HEX BOLTS	
(2) M10 BOLT PLATES	

PROCEDURE

1. Begin installation by working on driver side of the vehicle (refer to Figures 1. 1- 1.5)
2. From underneath truck, loosen and remove body mount bolts that run upward through mounts into floorboard. Attach and secure Front Mount Bracket to underside of vehicles front body mount (see Figure 1.3), re-using isolator, but replacing factory bolt with (1) M12 – 1.75 x 120mm bolt, (1) 1/2" LOCK WASHER, and (1) M12 FLAT WASHER. Also,
3. Attach and secure Rear Mount Bracket to underside of vehicles rear body mount in same manner as the front.
4. Attach and secure Center Brace brackets. See Figure 1.3 to know where to install the Center Brace Brackets.
5. Attach Front Brace Bracket to side of Front Mount Bracket using (1) M10X40mm bolt, (2) M10 flat washers, and (1) M10 hex nut ,(1) lock washer (see Figure 1.5). Place (1) 3/8" x 1 1/2" bolt with welded strap and (1) M12 flat washer through cut out in frame rail. Line up slot on the long arm of the Brace Bracket with this bolt and secure using (1) M10 flat washer and (1) M10 lock nut,(1) lock washer. Hand tighten.
6. Attach Side Tube to Front and Rear Brackets using (1) M12 – 1.75 x 60mm HEX HEAD BOLT, (1) M12 split lock washer and (1) M12 flat washer for each bracket, and hand tighten. Torque M12 bolts first to 65 ft-lbs and then tighten all remaining fasteners to complete the driver-side assembly.
7. Repeat process for passenger side of vehicle to complete installation.



1500/2500/3500 Front Brace

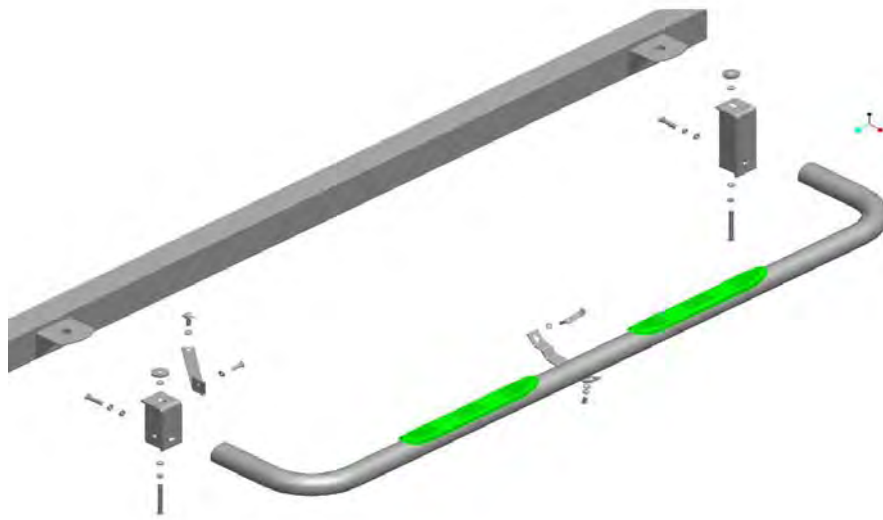

Attach center support bracket as shown in Fig.3-4. Place hooked T-bolt through body with threaded stud through hole. Secure bracket to bolt using 3/8 nut, lock-washer, and flat washer. Attach side bar to center support bracket with 3/8 bolt, lock washer, and flat washer

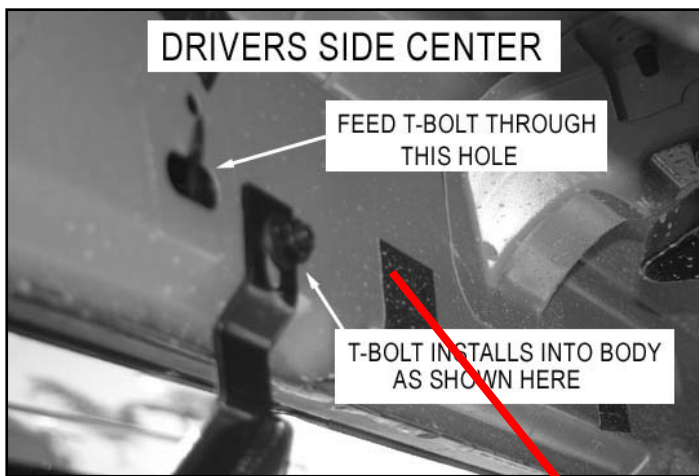

The customer should take off the black sticker on the middle of frame, and then they will see two holes there. Use the T-bolt (bolt plate) hook the center hole through the neighbor hole like the left picture above. After that, they can install the center bracket without any problem.

Figure 1.3 –Driver-Side Front Assembly View (1500/2500/3500 Series set-up shown)

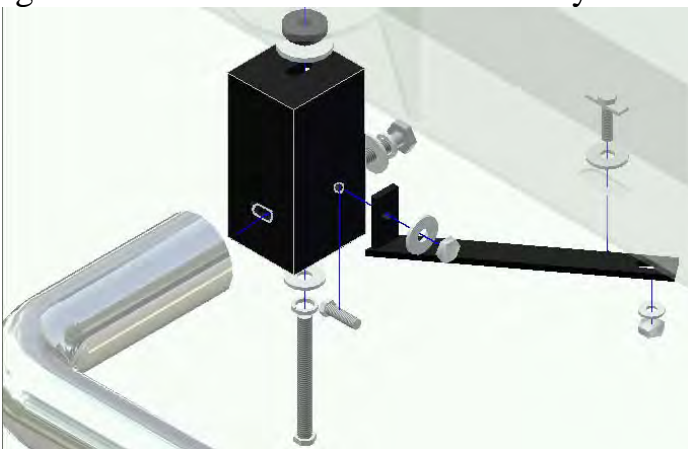

Figure 1.5 – 1500/2500/3500 Front Mount Assembly