



**Before returning this product
to the store of purchase**

Contact Dee Zee if you experience the following problems:

- Missing Parts
- Installation Problems/Questions
- Warranty Questions

1.800.779.2102

Hours of operation: 8am - 5pm CST, Mon-Friday

Review complete warranty policy and register your product at:

www.deezee.com/warranty.php

INSTALLATION INSTRUCTIONS

SIDEBAR PART # 371821/371823

08 TOYOTA HIGHLANDER

PARTS LIST:

1	Driver/Left Sidebar	2	12mm Lock Washers
1	Passenger/Right Sidebar	2	12mm Hex Nuts
1	Driver/Left Front Mounting Bracket	2	12mm Oversize Hex Nuts
1	Passenger/Right Front Mounting Bracket	2	12mm ID x 35mm OD x 3mm Flat Washers
1	Driver/Left Rear Mounting Bracket	2	6-1.00mm x 25mm Hex Bolts
1	Passenger/Right Rear Mounting Bracket	2	6mm ID x 19mm OD x 1.5mm Flat Washers
2	12-1.75mm x 30mm Bolt Plate	2	6mm Lock Washers
2	12-1.75mm x 90mm Bolt Plate	8	8-1.25mm x 25mm Hex Bolts
2	6mm Nut Plate	8	8mm Lock Washers
		8	8mm ID x 22m OD x 3mm Flat Washers

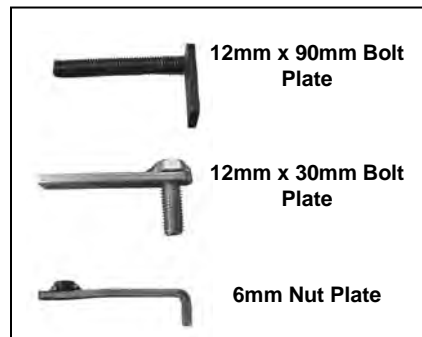
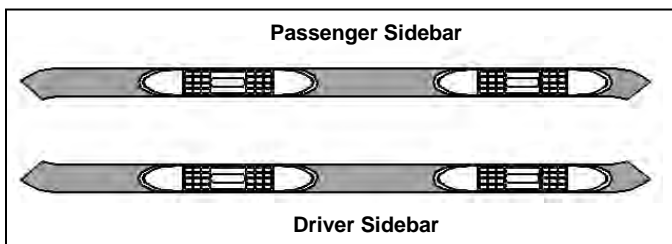
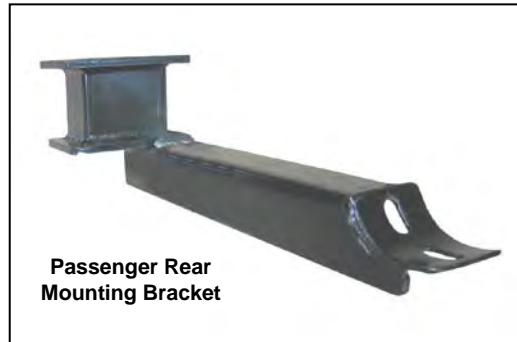
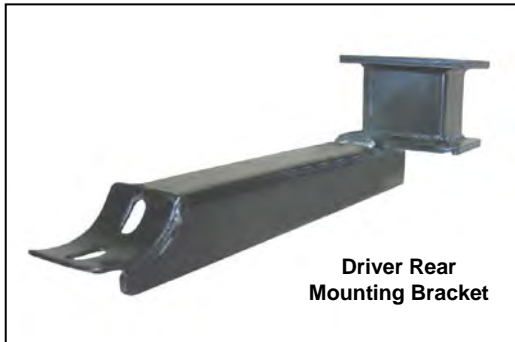
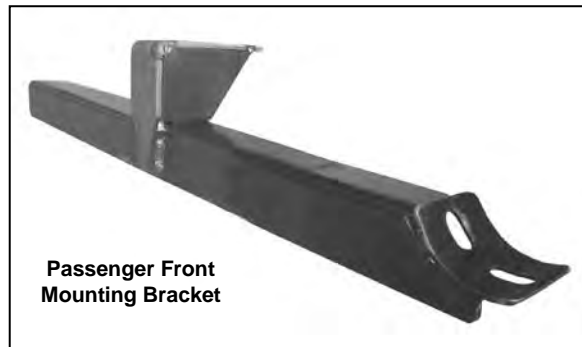

PROCEDURE:

1. REMOVE CONTENTS FROM BOX. VERIFY ALL PARTS ARE PRESENT. READ INSTRUCTIONS CAREFULLY BEFORE STARTING INSTALLATION.
2. From underside of vehicle, remove front and middle section of the driver side plastic rock guard (**Figure 1 & 2**).
3. Place the plastic rock guard on a clean working area. Use a hack saw to cut out an opening 2" x 3 1/2" on the middle rock guard as marked in **Figure 1**. Cut a 1 1/2" x 1 1/2" opening in the front guard as marked in **Figure 1 & 2**.
4. Re-position plastic rock guard back to the vehicle and tighten it using the factory fasteners.
5. Insert (1) 12mm x 30mm Bolt Plate into factory hole in the inner frame rail located by the front tie downs (**Figure 3**).
6. There are four factory holes in the cross frame rail, two holes front to back and two perpendicular. Insert (1) 6mm Nut Plate into the outer perpendicular hole (larger) and orient it to the rear front to back hole (**Figure 4**).
7. Partially hang driver side front Mounting Bracket to already inserted 12mm Bolt plate and secure it using (1) 12mm Lock Washer, (1) 12mm Flat Washer, and (1) 12mm Hex Nut (**Figure 5**). Proceed to attach the outer side of the front Mounting Bracket to already inserted 6mm Nut Plate and secure it using (1) 6mm x 25mm Hex Head Bolt, (1) 6mm Lock Washer, and (1) 6mm Flat Washer (**Figure 5**).
8. Remove the rubber grommet located in the rear floor panel. Insert (1) 12mm x 90mm Bolt Plate into existing oval factory hole (**Figure 6**).
9. Partially hang driver rear Mounting Bracket to already inserted Bolt Plate. Use the included (1) 12mm Oversize Hex Nut (**Figure 7**).
10. Position driver's Sidebar onto Mounting Brackets. Use the included (4) 8mm x 25mm Hex Head Bolts, (4) 8mm Lock Washers, and (4) 8mm Flat Washers to attach Sidebar to Mounting Brackets (**Figure 7**).
11. Align Sidebar properly, and then tighten all hardware at this time.
12. Repeat steps 2 – 11 for passenger Sidebar. **NOTE:** On the passenger you would need to remove the entire plastic rock guard. The cutting location is the same as the driver side.
13. Do periodic inspections to the installation to make sure that all hardware is secure and tight.

(Driver Sidebar Installation Shown)

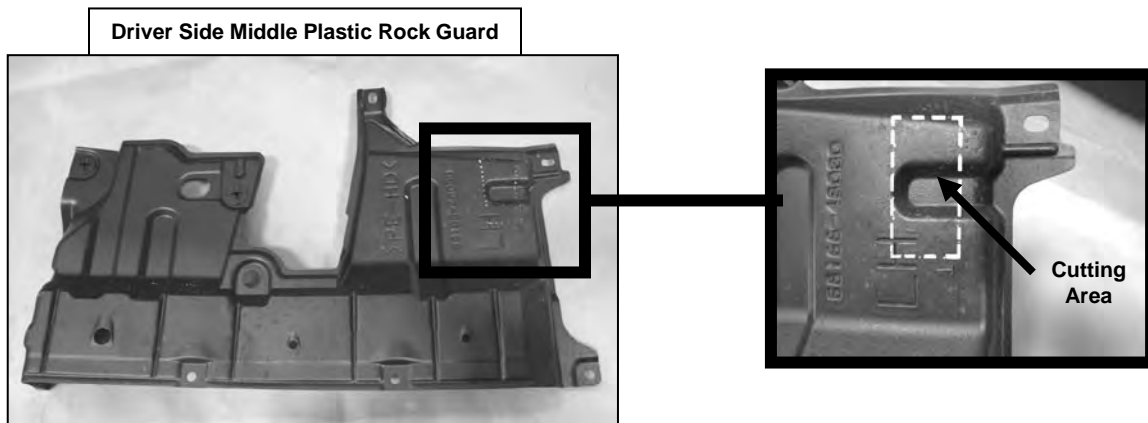

Fig 1

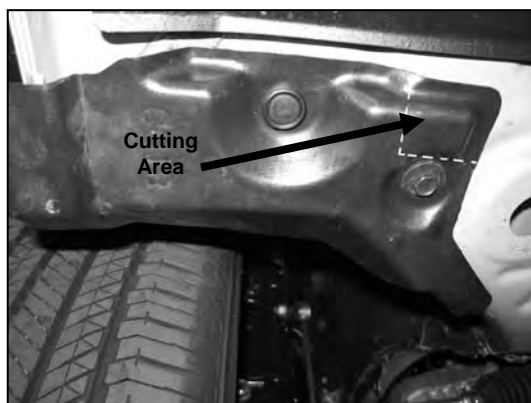

Fig 2

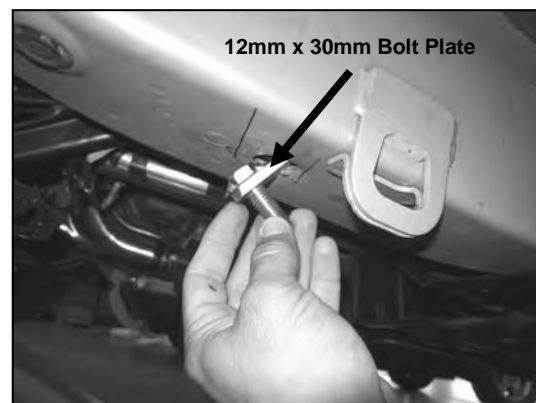

Fig 3

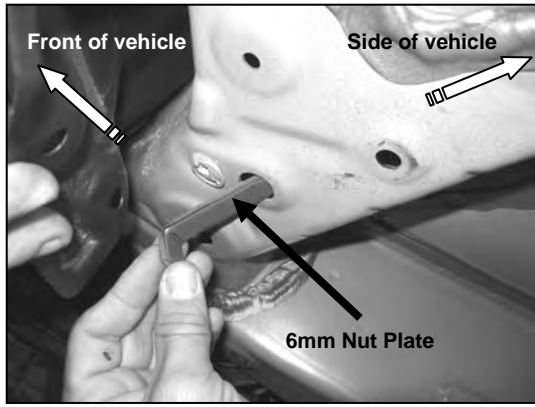

Fig 4

(6mm Nut Plate)
6mm x 25mm Hex Bolt
6mm Lock Washer
6mm Flat Washer

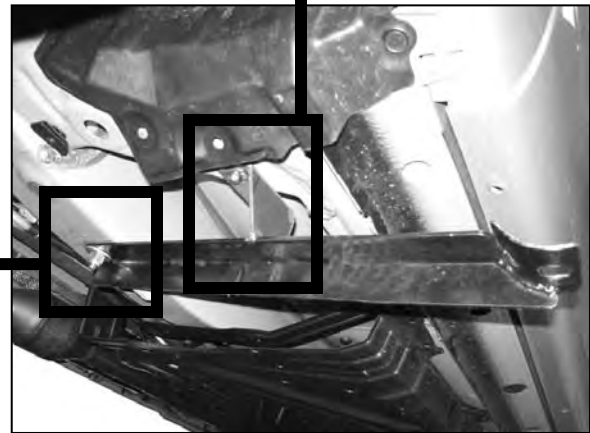

Fig 5

(12mm x 30mm Bolt Plate)
12mm Lock Washer
12mm Flat Washer
12mm Hex Nut

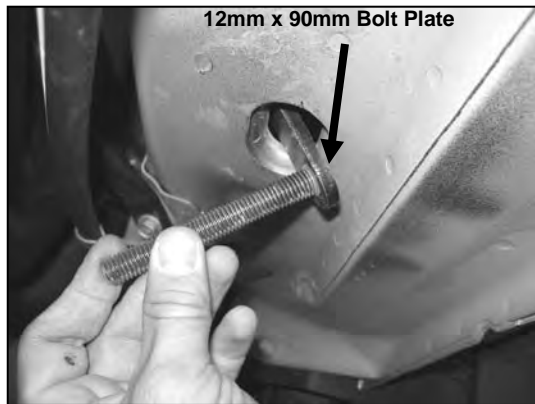

Fig 6



Fig 7

8mm x 25mm Hex Bolts
8mm Lock Washers
8mm Flat Washers

(12mm x 90mm Bolt Plate)
12mm Double Nut



Fig 8

Installation Complete