



**Before returning this product
to the store of purchase**

Contact Dee Zee if you experience the following problems:

- Missing Parts
- Installation Problems/Questions
- Warranty Questions

1.800.779.2102

Hours of operation: 8am - 5pm CST, Mon-Friday

Review complete warranty policy and register your product at:

www.deezee.com/warranty.php

INSTALLATION INSTRUCTIONS

GRILL GUARD

06-08 DODGE RAM 1500

PART#DZ 502244/DZ 502245

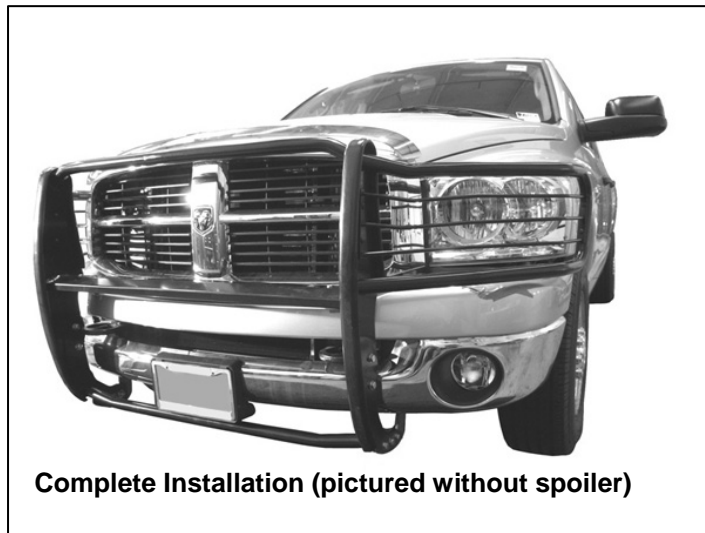

PARTS LIST:

Qty	Description	Qty	Description
1	Grille Guard	12	12mm x 24mm OD x 2.5mm Flat Washers
1	Driver/Left Frame Mounting Bracket	10	12-1.75mm Nylon Lock Nuts
1	Passenger/Right Frame Mounting Bracket	2	10-1.5mm x 35mm Hex Bolts
2	Mounting Brackets	4	10mm x 20mm OD x 2mm Flat Washers
2	Top Mounting Brackets	2	10mm Nylon Lock Nuts
1	Driver/Left Top Support Bracket	1	5mm Wrench
1	Passenger/Right Top Support Bracket	2	8mm x 25mm Button Head Allen Bolts
10	12-1.75mm x 35mm Hex Bolts	4	8mm x 16mm OD x 1.6mm Flat Washers
12	12mm x 32mm OD x 3mm Flat Washers	2	8mm Nylon Lock Nuts

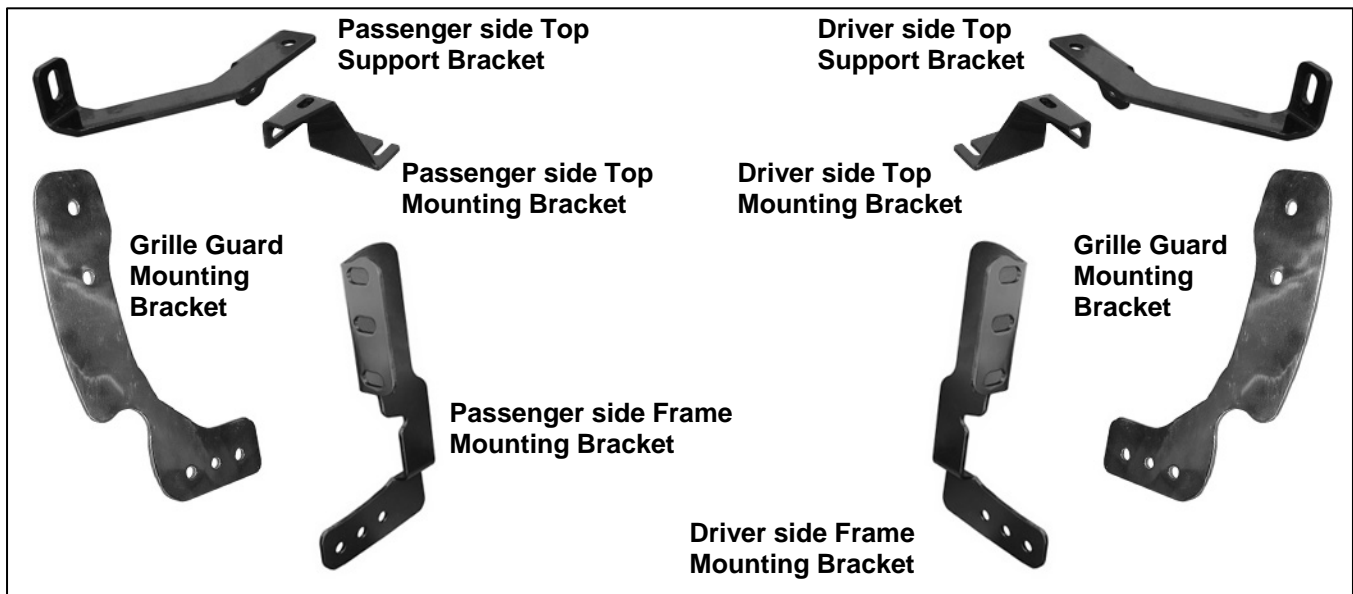

PROCEDURE:

- 1. REMOVE CONTENTS FROM BOX. VERIFY ALL PARTS ARE PRESENT. READ INSTRUCTIONS CAREFULLY BEFORE STARTING INSTALLATION. CUTTING IS REQUIRED. ASSISTANCE IS RECOMMENDED.**
- Begin the installation at the underside of the front bumper. Carefully release the bolts and/or factory clips and remove the plastic spoiler. **NOTE:** It may be necessary to remove the bumper mounted factory fog light or cover (if equipped) to access the spoiler hardware. Place the spoiler on a clean, stable work surface.
- Starting on the passenger side, remove the (2) factory hex nuts from the bumper bolts securing the bumper bracket to the back of the bumper. Select the driver side Frame Mounting Bracket and hold it up behind the bumper. Align the holes in the Frame Mounting Bracket with the (2) bumper bolts. Attach the Bracket to the bumper bolts using the factory hex nuts, **(Figure 1)**. Snug but do not tighten the hardware at this time.
- Cover the top of the bumper cover with a layer of masking tape to prevent damage to the cover during bracket installation, **(Figure 4)**. Remove the (2) factory hex bolts located on the bottom of the crossmember, **(Figure 2A& 2B)**. Select the passenger side Top Frame Mounting Bracket and attach it to the crossmember using the factory hex bolts, **(Figure 3)**. Push the Bracket back against the crossmember and tighten the factory hardware on this bracket only at this time.

5. Secure the passenger side Top Bracket to the Top Mounting Bracket with the included (1) 10mm x 35mm Hex Bolt, (2) 10mm Flat Washers and (1) 10mm Nylon Lock Nut. Insert (1) 12mm x 35mm Hex Bolt, (2) 12mm Flat Washers and (1) 12mm Nylon Lock Nut through the slotted hole on the side of the Top Bracket, **(Figure 4)**. Snug but do not tighten hardware at this time.
6. Repeat Steps 3-5 for the driver side Mounting Bracket installation.
7. Lay the Grille Guard face down on a clean surface on the ground in front of the vehicle. Bolt the Mounting Brackets to each upright on the Grille Guard using the included (4) 12-1.75mm x 35mm Hex Head Bolts, (8) 12mm x 24mm OD x 2.5mm Flat Washers, and (4) 12mm Nylon Lock Nuts, (2 per side, see **Figure 5**). Tighten this hardware only at this time.
8. Raise the Mounting Brackets on the Grille Guard up to the outside of the Frame Mounting Brackets. Insert (1) 12-1.75mm x 35mm Hex Head Bolt, (2) 12mm 32mm OD x 3mm Flat Washers and (1) 12mm Nylon Lock Nut into each of the rear-most mounting holes to act as a hinge. With assistance, rotate the Grille Guard up to line up with the Top Brackets and insert (4) 12-1.75mm x 35mm Hex Head Bolts, (8) 12mm x 32mm OD x 3mm Flat Washers and (4) 12mm Nylon Lock Nuts into the remaining holes in the Mounting Brackets, **(Figure 6)**. Use (2) 8mm x 20mm Button Head Allen Bolts, (4) 8mm x 22mm OD x 1.5mm Flat Washers and (2) 8mm Nylon Lock Nuts to fasten the Top Bracket to the Grille Guard, **(Figure 7)**. **IMPORTANT:** Slowly close the hood to check for clearance and fit of the Grille Guard and brackets. Adjust the Brackets as necessary then snug but do not tighten all of the hardware. Due to factory build variances in vehicles, it may be necessary to adjust the height of the front bumper to provide additional clearance for the Grille Guard Top Brackets. Loosen the bumper mounting hardware and adjust as necessary.
9. Stand back from the vehicle and check the Grille Guard alignment, for level and if it is centered and on the vehicle. Adjust as necessary. **IMPORTANT:** Once properly aligned, tighten only the hardware securing the Frame Mounting Brackets to the truck. Do not tighten the hardware on the Grille Guard. Leave the Frame Mounting Brackets and Top Brackets on the vehicle and remove the Grille Guard
10. Next, hold the spoiler up to the bumper cover and align it with the mounting points. Mark the location of the Mounting Brackets onto the spoiler, **(Figure 8)**. Cut an approximately 1/2" wide slot in the lower portion of the spoiler to clear the Mounting Brackets. **NOTE:** The size of the slot is an estimate only and may vary due to different factory designs for the spoiler and front bumper covers. **IMPORTANT:** To maintain the integrity of the spoiler, do not cut the slot any larger than necessary. Do not cut through the mounting surface. It is recommended to make several small cuts and check the fit often for a clean installation.
11. Once the final cuts have been made, re-install the spoiler using the factory hardware. It may be necessary to remove the Frame Mounting Brackets for more clearance to reinstall the spoiler.
12. Re-install, level and adjust the Grille Guard as described in Step # 8-9. Tighten all hardware.
13. Do periodic inspections of the installation to make sure that all hardware is secure and tight.

To protect your investment, wax this product after installing. Regular waxing is recommended to add a protective layer over the finish. Do not use any type of polish or wax that may contain abrasives that could damage the finish.

For stainless steel: Aluminum polish may be used to polish small scratches and scuffs on the finish. Mild soap may be used also to clean the Grille Guard.

For gloss black finishes: Mild soap may be used to clean the Grille Guard

Passenger Side Installation Pictured

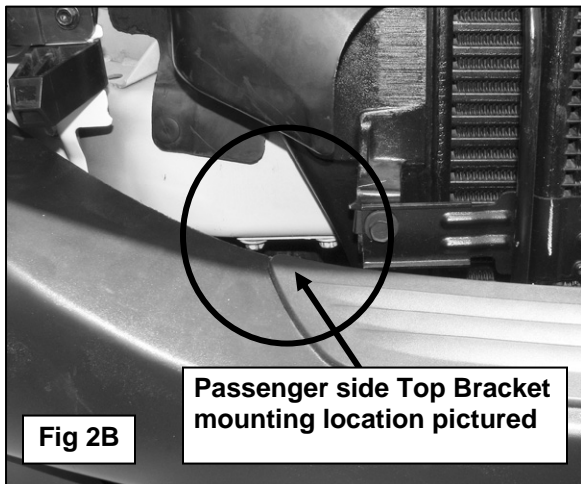
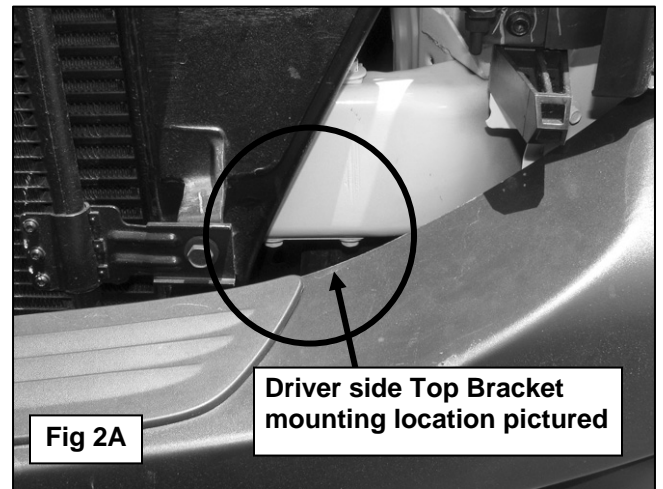
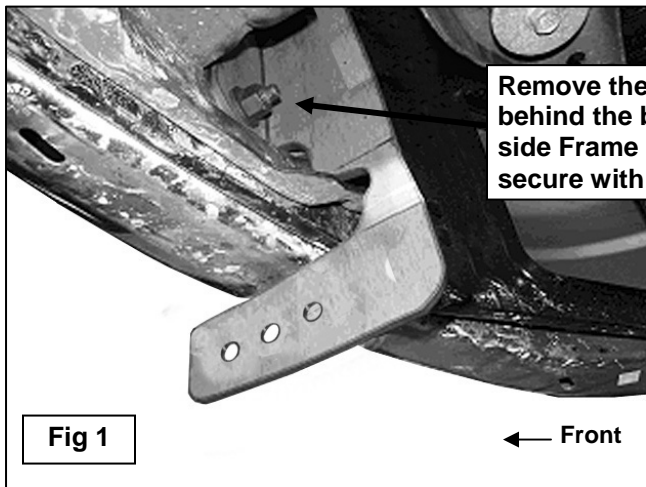

Use the 8mm factory hex bolt to attach the Top Mounting Bracket to the crossmember

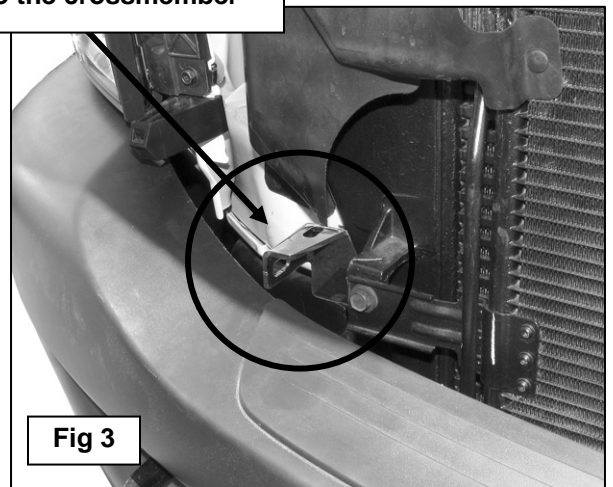

- 12-1.75mm x 35mm Hex Bolts
- 12mm x 24mm OD x 2.5mm Flat Washers
- 12mm Nylon Lock Nuts

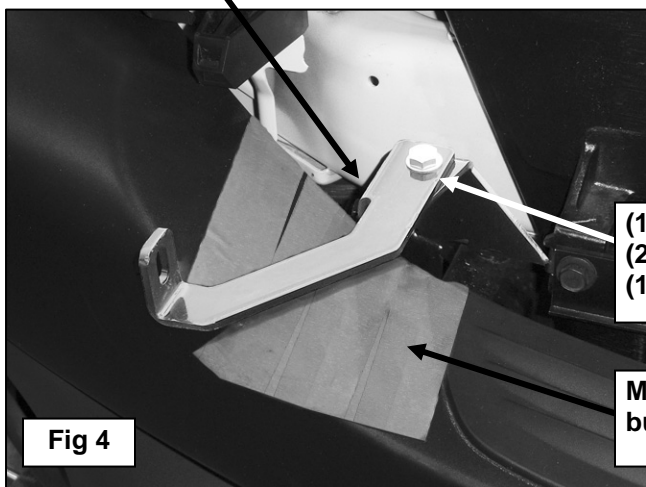

Passenger Side Installation Pictured

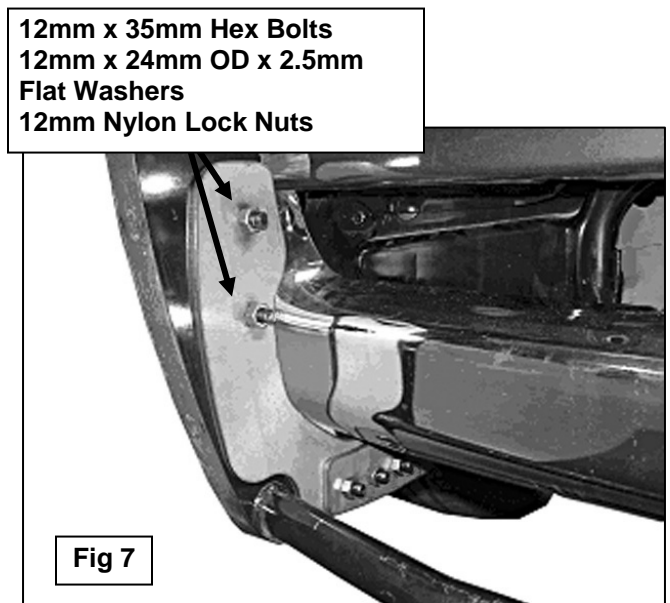
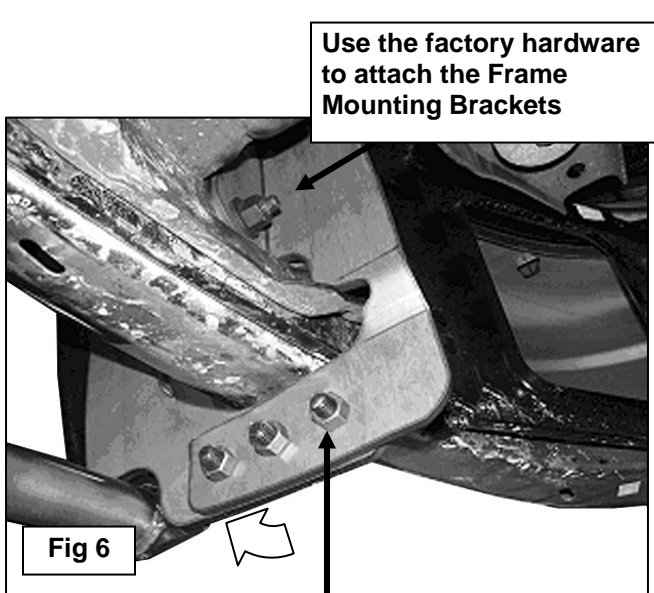
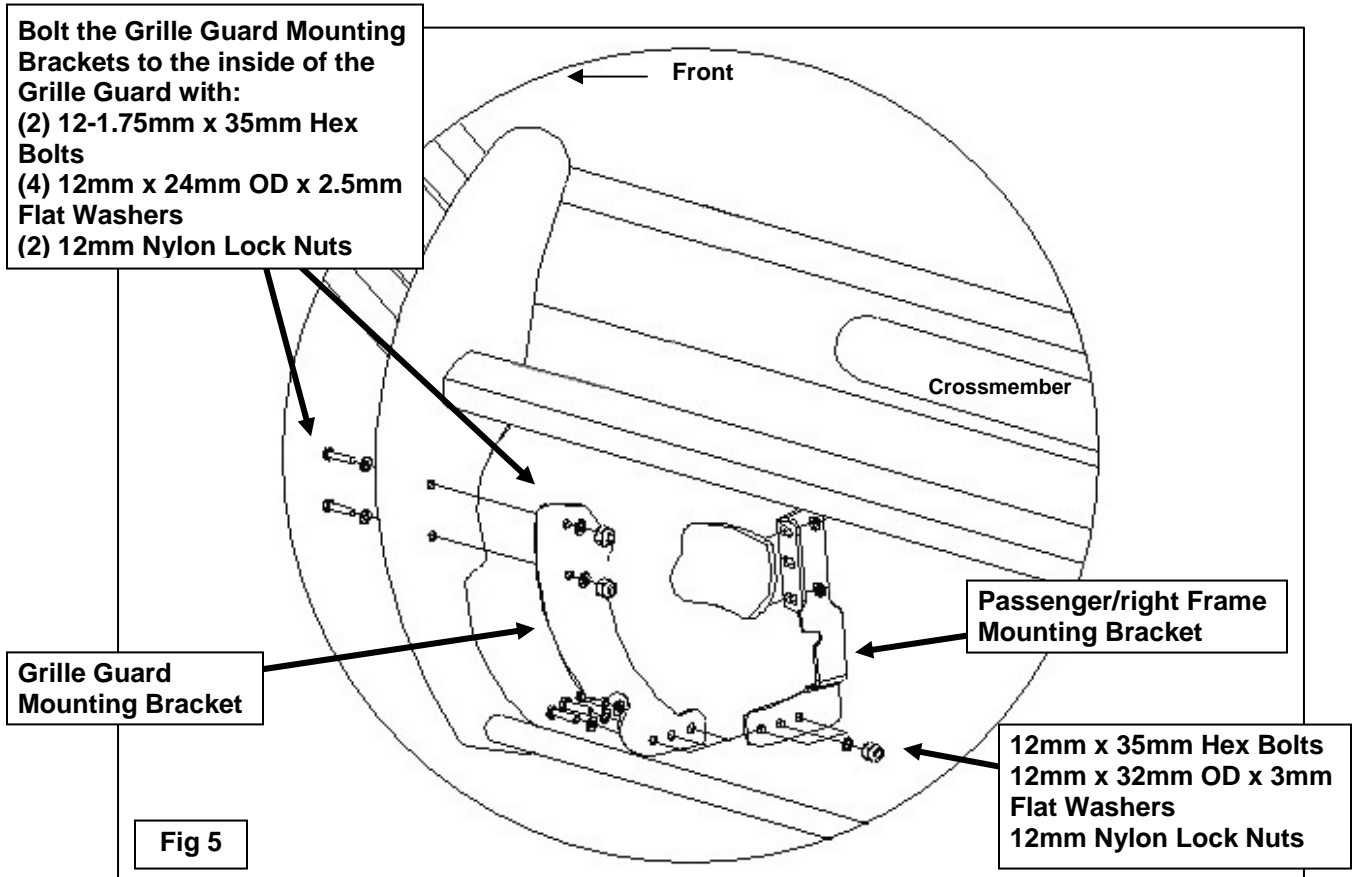

Start Grille Guard installation by inserting (1 per side) Hex Bolt with hardware in the rear-most mounting holes first to act as a hinge. Tilt the Grille Guard up into position and install remaining hardware

Passenger Side Installation Pictured

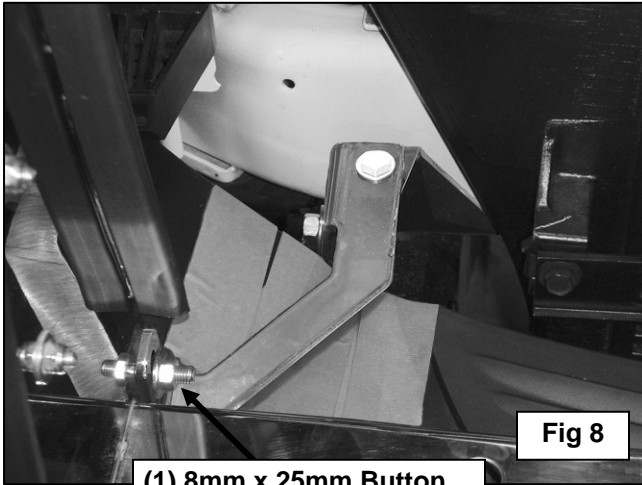

- (1) 8mm x 25mm Button Head Allen Bolt
- (2) 8mm Flat Washers
- (1) 8mm Nylon Lock Nut

Warning: Do not cut through the mounting area (top) of the spoiler

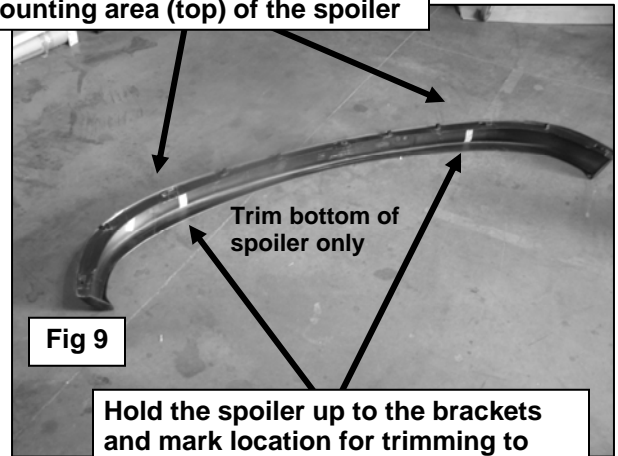

Hold the spoiler up to the brackets and mark location for trimming to clear brackets. Cut only the material required to clear the brackets. To maintain strength, it is not necessary or recommended to cut through the mounting edge (top) of the spoiler

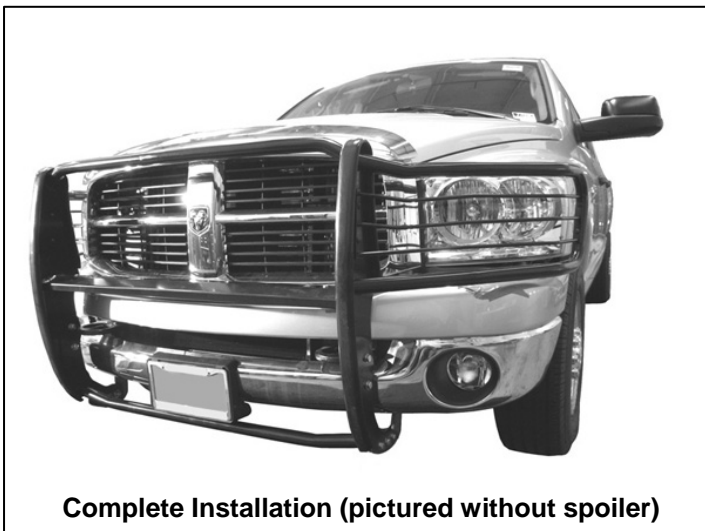

Complete Installation (pictured without spoiler)