



**Before returning this product
to the store of purchase**

Contact Dee Zee if you experience the following problems:

- Missing Parts
- Installation Problems/Questions
- Warranty Questions

1.800.779.2102

Hours of operation: 8am - 5pm CST, Mon-Friday

Review complete warranty policy and register your product at:

www.deezee.com/warranty.php

Installation Instructions

Grill/Brush Guard

04-on Ford F-150 Pick Up (Non Heritage)

Step One: Locate hardware and check the contents with the hardware listed below.

QTY	DESCRIPTION
2	Top Support Brackets (04-05 models)
2	Top Support Brackets (06-07 models)
2	L-Brackets Mounts (06-07 models)
2	Retainer Bracket (use for all 2wd models)
2	Lower Mounting Brackets (Passenger & Driver) (04-07 models)
8	M12 x 30mm Hex Head Bolts
12	M12 Oversized Flat Washers
4	M12 Lock Nuts
2	M10 x 40mm Hex Head Bolts
2	M10 x 25mm Round Head Bolts
4	M10 Oversized Flat Washers
2	M10 Flat Washers
2	M10 Lock Nut

Step Two: Locate the Passenger side Lower Mounting Bracket, (1) Retainer Bracket, (2) M12 x 30mm Hex Head Bolts, and (2) M12 Oversized Flat washers. Insert Retainer Bracket through the front of the frame as shown in Fig 1 & 2. Line up holes on the bracket with holes on the frame. Make sure the flat side of the Retainer Bracket is facing down when inserted into the frame. Orient Lower Mounting Bracket as per Fig 1 & 2 and loosely install it to the Retainer Bracket by using the hardware listed in this step. **NOTE:** On all 4wd models, tow hooks are re-mountable and will be using factory existing bolts to install the Mounting Bracket. Repeat this step for opposite side.

Step Three: Locate (4) M12 x 30mm Hex Head Bolts, (4) M12 Lock Nuts, and (8) M12 Oversized Flat Washers. Position the Guard on the vehicle and place the lower portion of the guard to the outside of the Lower Mounting Brackets as per Fig 1 & 2. Secure the Guard to Mounting Brackets with hardware listed in this step. Do not tighten hardware at this time.

Step Three: Locate driver side Top Bracket, (2) M10 x 40mm Hex Head Bolt, and (2) M10 Flat Washers. Open hood and locate the Top Bracket mounting location (Fig 3). **NOTE:** The Top Bracket mounting location is located in the inside of the vehicle next to the rubber stopper. Attach Bracket by using the hardware listed in this step. Do not tighten hardware at this time. Repeat this step for opposite side.

For 06-07 models you will need to install an “L” bracket before installing Top Bracket, refer to page 3 for “L” Bracket and Top Bracket installation.

To install the “L” Bracket, locate the existing hole through the bumper intake (Fig 4). Position the “L” Bracket behind existing hole. Attach “L” Bracket with the included M12 x 30mm Hex Bolts, M12 Flat Washers, and M12 Nylock Nut (Fig 5).

Step Four: Locate (2) M10 x 25mm Round Head Bolts, (4) M10 Oversized Flat Washers, and (2) M10 Lock Nuts. Attach the front of the Front Support Brackets to the Guard by using the hardware listed in this step (Figure 3). Center Guard and tighten all hardware at this time.

Figure 1

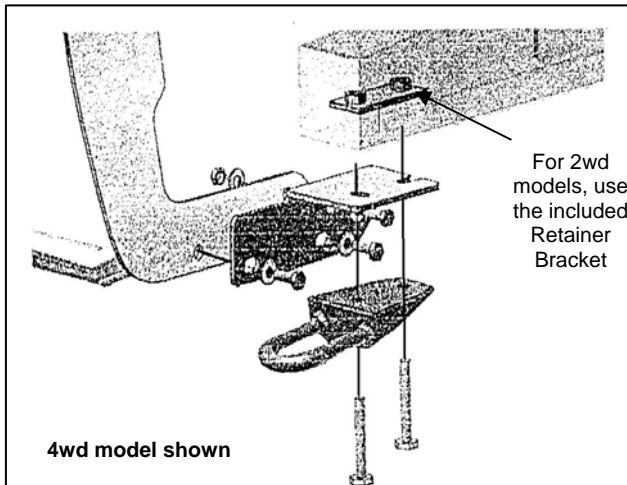
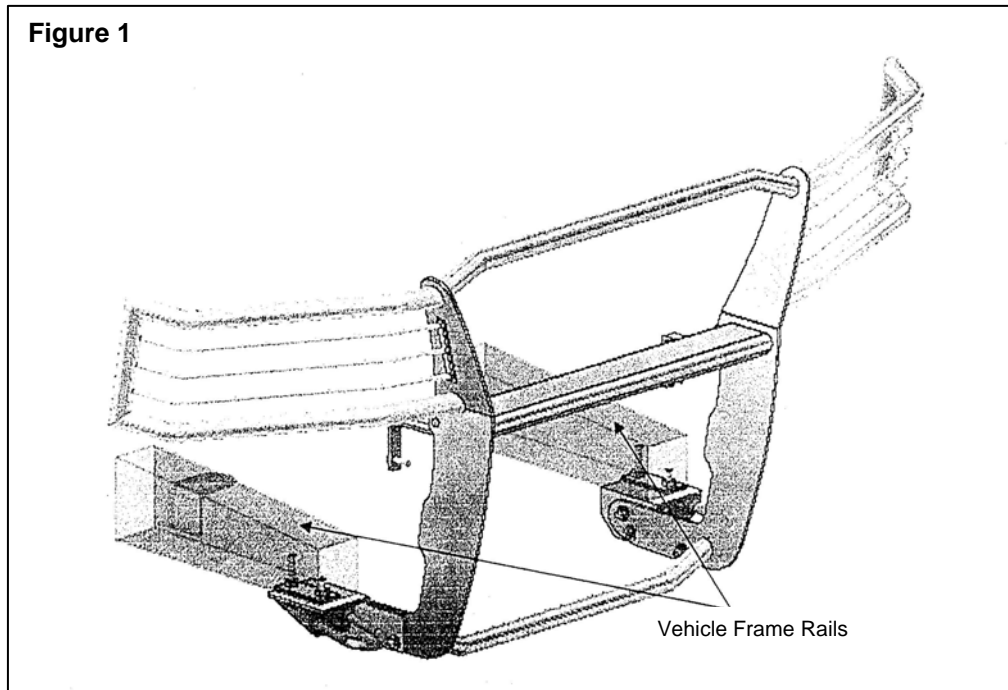

Figure 2

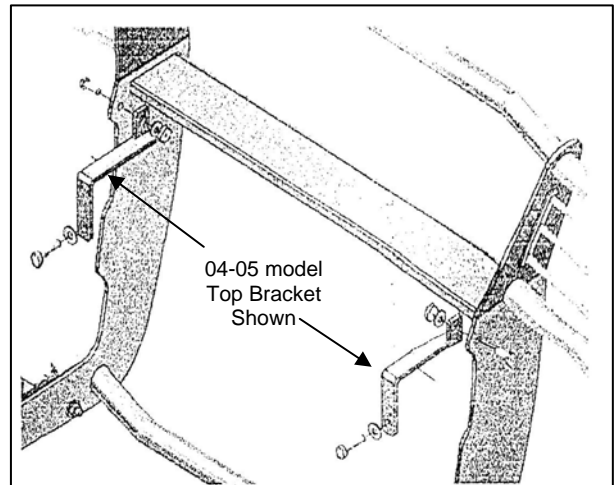
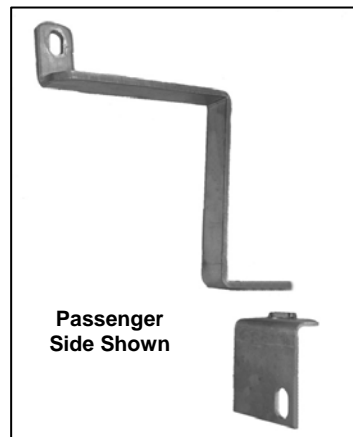

Figure 3



Note:

FORD F150 / TOP SUPPORT ASSEMBLY FOR 06-07 MODELS ONLY



Driver side existing hole shown

Figure 4

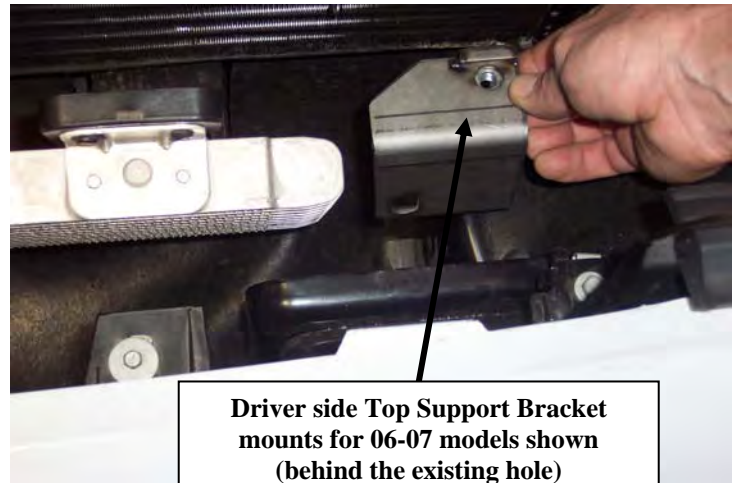

Driver side Top Support Bracket mounts for 06-07 models shown (behind the existing hole)

Figure 5

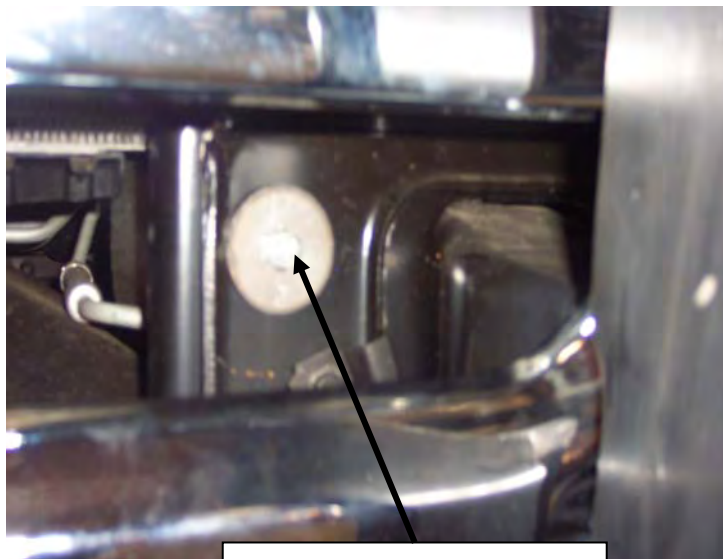

Driver side shown. (Top Support Bracket mounts behind existing hole with M12 x 30mm Hex Bolts)

Figure 6

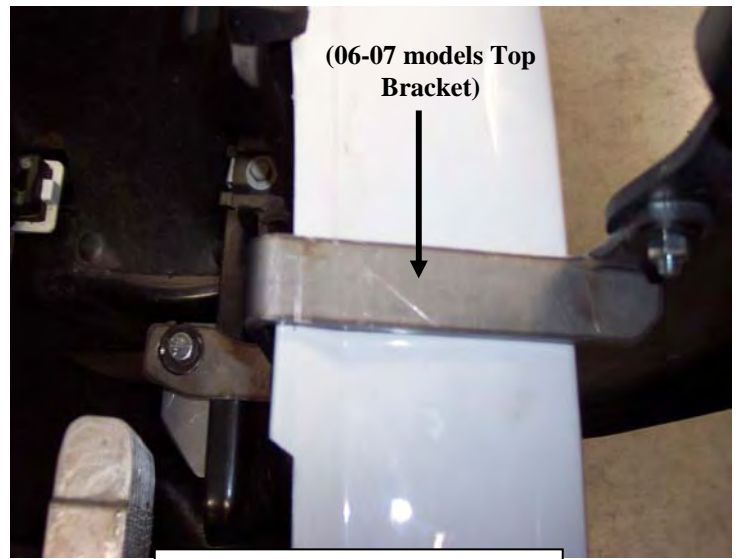

Driver side shown. Attach Top Support Bracket to the "L" Bracket previously installed using the M10 Hex Head Bolts

Figure 7