

INSTALLATION INSTRUCTIONS
SIDEBAR WITH BEND
07-ON TOYOTA TUNDRA REG / DOUBLE / CREW MAX CAB /
08-ON TOYOTA SEQUOIA
PART #

PARTS LIST:

1	Driver/Left Sidebar	4	1/2" x 2" Hex Head Bolts
1	Passenger/Right Sidebar	4	1/2" Lock Washers
1	Driver/Left Front Mounting Bracket	4	1/2" ID x 1 3/8" OD x 3/32" Flat Washers
1	Driver/Left Rear Mounting Bracket	8	8-125mm x 35mm Hex Head Bolts
1	Passenger/Right Front Mounting Bracket	2	8-1.25mm x 25mm Hex Head Bolts
1	Passenger/Right Rear Mounting Bracket	2	8mm Hex Nuts
2	10mm x 30mm Bolt Plates	10	8mm Lock Washers
		12	8mm ID x 22mm OD x 1.5mm Flat Washers
		2	10mm Lock Washers
		2	10mm Hex Nuts
		2	10mm ID x 26mm OD x 3mm Flat Washers

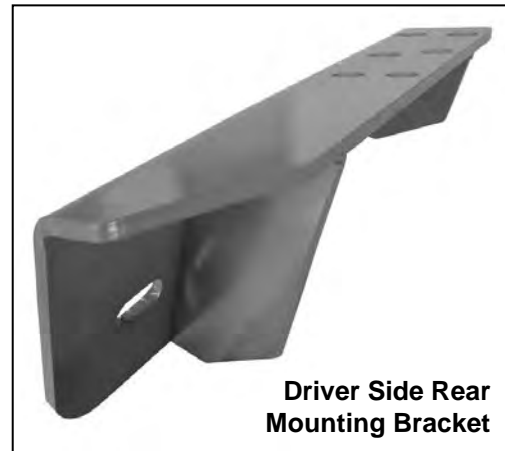

PROCEDURE:

- 1. REMOVE CONTENTS FROM BOX. VERIFY ALL PARTS ARE PRESENT. READ INSTRUCTIONS CAREFULLY BEFORE STARTING INSTALLATION. DRILLING REQUIRED**
2. Starting on the driver side front of the vehicle, locate the two factory threaded holes and a factory round hole in the side panel (**Figure 1**). **NOTE:** You need to remove plastic plug to uncover the round hole.
3. Insert one of the 10mm x 30mm Bolt Plate into factory round hole (**Figure 2**). **NOTE:** Insert Bolt Plate from front to back, and once it's inside the frame push all the way towards the front of the vehicle to fully engage
4. Position driver side Mounting Bracket over already inserted Bolt Plate. Use the included (1) 10mm Lock Washer, (1) 10mm Flat Washer, and (1) 10mm Hex Nut to secure Bracket to Bolt Plate (**Figure 3**). Do not tighten at this time.
5. Partially secure the other mounting locations of the Bracket to the two factory threaded holes by using the included (2) 8mm x 35mm Hex Head Bolts, (2) 8mm Lock Washers, and (2) 8mm Flat Washers (**Figure 3**).
6. Locate the two factory threaded holes in the side panel by the rear body mount (**Figure 4 & 5**).
7. Refer to **Figure 6** to determine the mounting holes you will be using to install the Rear Mounting Bracket to vehicle.
8. Position Bracket up to side panel and align holes in the bracket with factory threaded holes in the vehicle. Use the included (2) 8mm x 35mm Hex Head Bolts, (2) 8mm Lock Washers, and (2) 8mm Flat Washers to attach rear Bracket to vehicle (**Figure 7, 8 & 9**). Do not tighten at this time
9. Use the hole in the Bracket closer to the rear gusset as a template to mark the drilling location in the pinch weld (**Figure 10**).
10. Remove Bracket from vehicle and use a 5/16" drill bit to drill out the marked location.
IMPORTANT: Any cutting or drilling tool may break or shatter. Government regulations require safety glasses & equipment at all times when cutting or drilling.
11. Re-install rear Bracket back to threaded holes using the hardware listed in step eight. Attach rear Bracket to pinch weld using the included (1) 8mm x 25mm Hex Head Bolts, (1) 8mm Lock Washer, (1) 8mm Hex Nut, and (2) 8mm Flat Washers (**Figure 11**).
12. Position driver Sidebar up to Mounting Brackets and attach it using the included (2) ½" x 2" Hex Head Bolts, (2) ½" Lock Washers, and (2) ½" Flat Washers (**Figure 12 & 13**).
13. Adjust the Sidebar properly and then tighten all hardware at this time. **IMPORTANT!** Make sure that the Bolt Plates do not disengage when tighten the Mounting Brackets.
14. Repeat steps 2 – 13 for passenger Sidebar.
15. Do periodic inspections to the installation to make sure that all hardware is secure and tight.

To protect your investment, wax this product after installing. Regular waxing is recommended to add a protective layer over the finish. Do not use any type of polish or wax that may contain abrasives that could damage the finish.

For stainless steel: Aluminum polish may be used to polish small scratches and scuffs on the finish. Mild soap may be used also to clean the Sidebar.

For gloss black finishes: Mild soap may be used to clean the Sidebar

(Driver Side Installation Shown)

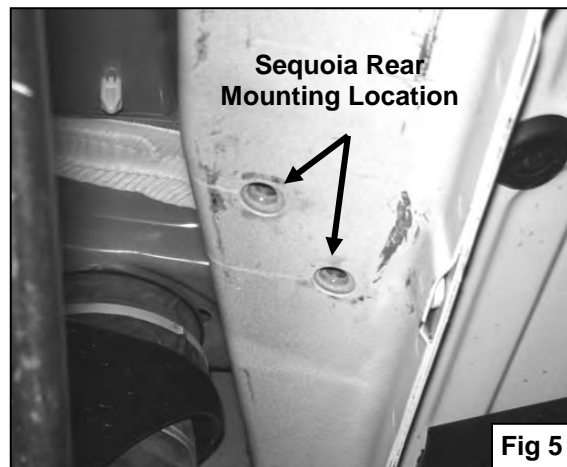
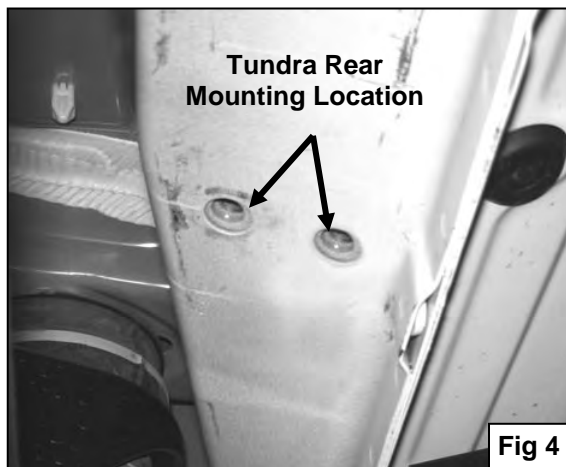
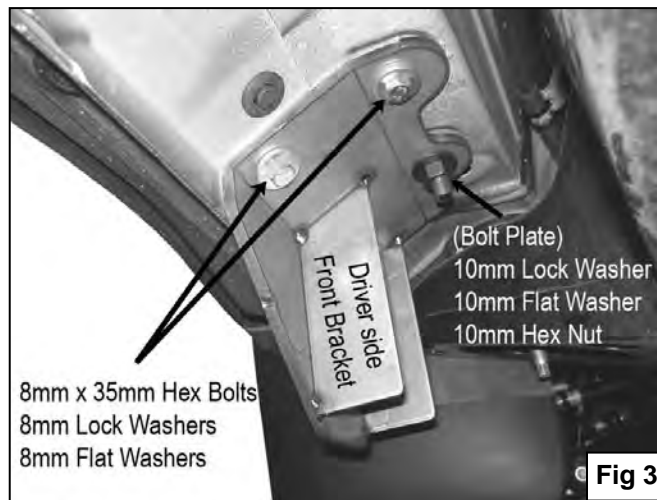

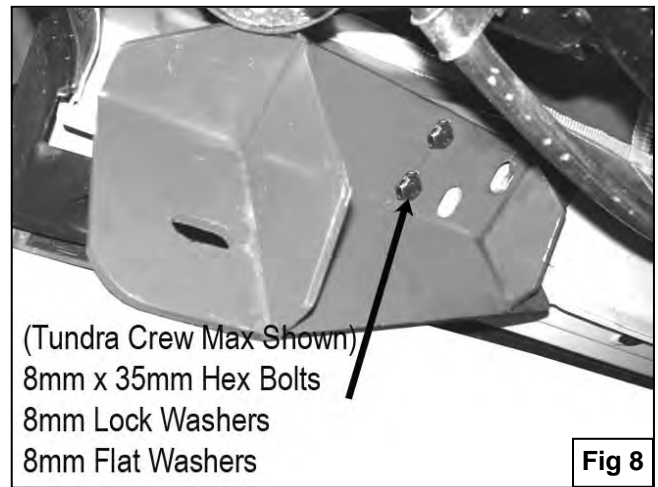
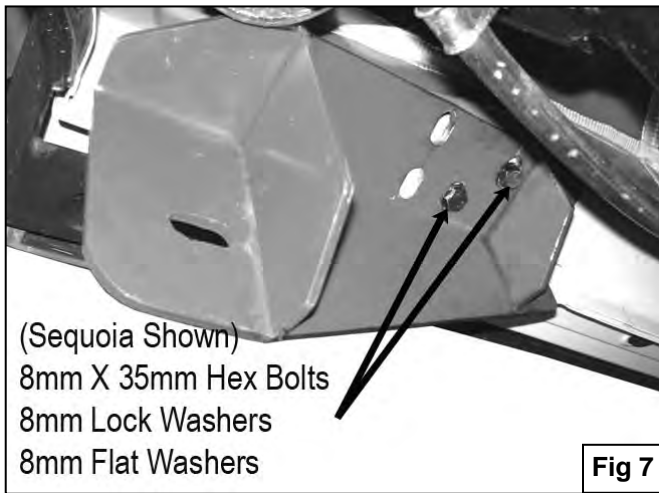
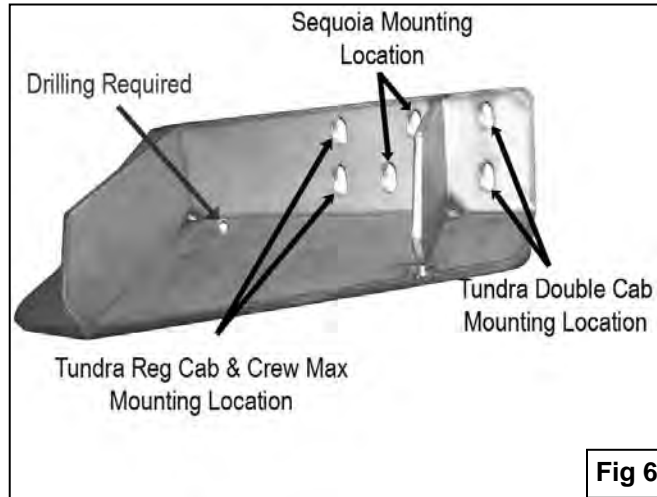

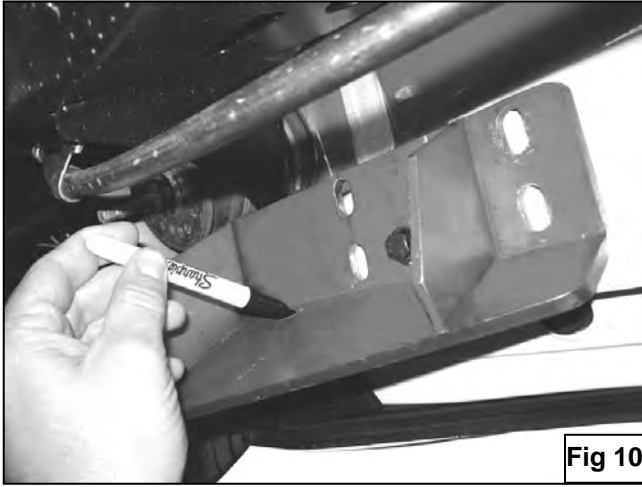
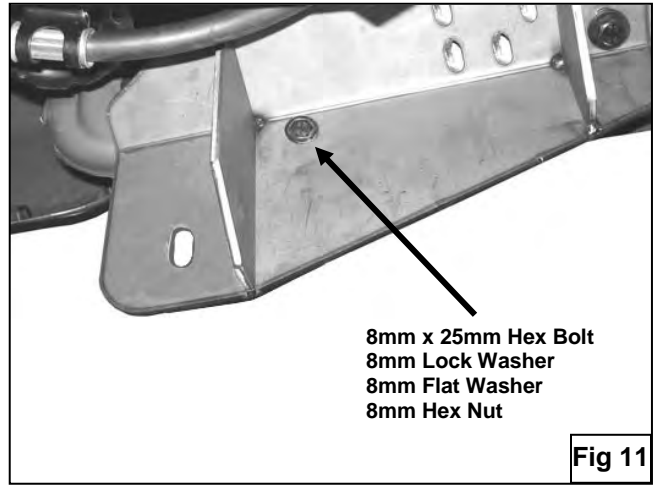

Fig 10



8mm x 25mm Hex Bolt
8mm Lock Washer
8mm Flat Washer
8mm Hex Nut

Fig 11

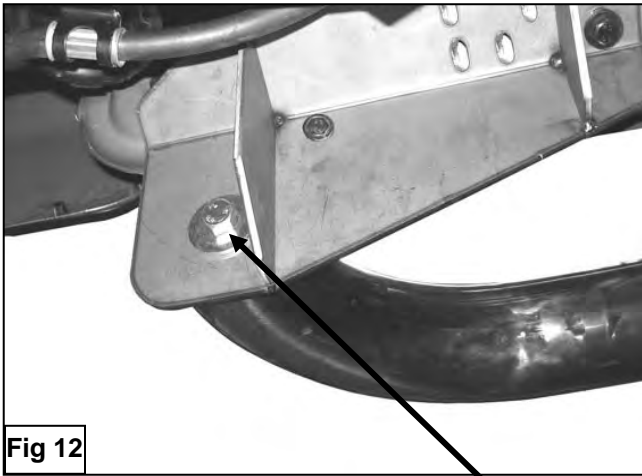

Fig 12

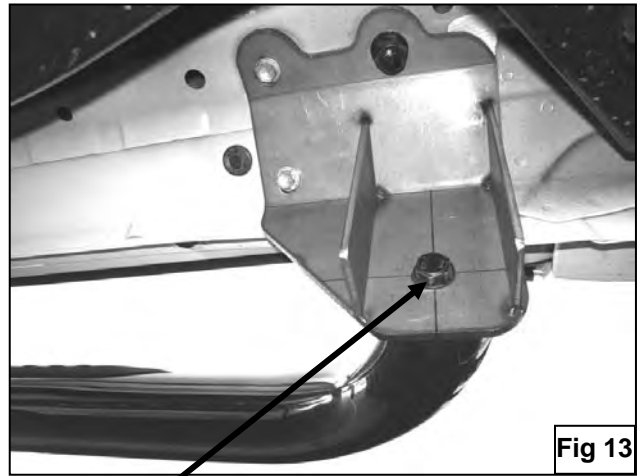

Fig 13

1/2" x 2" Hex Head Bolts
1/2" Lock Washers
1/2" Flat Washers



Sequoia Installation
Complete

Fig 14

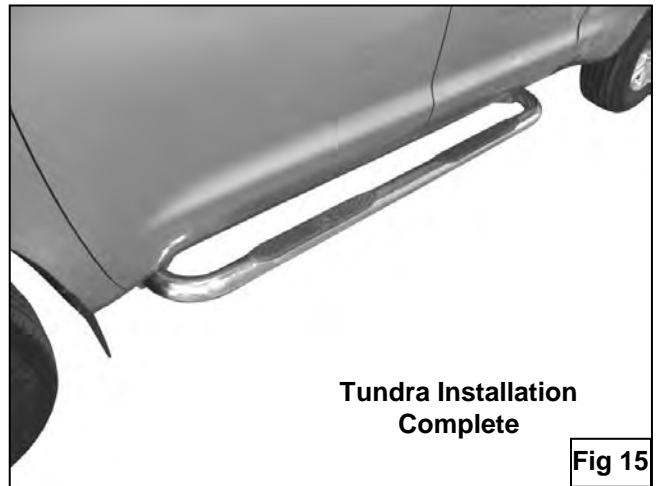

Tundra Installation
Complete

Fig 15