



**Before returning this product  
to the store of purchase**

**Contact Dee Zee if you experience the following problems:**

- Missing Parts
- Installation Problems/Questions
- Warranty Questions

**1.800.779.2102**

Hours of operation: 8am - 5pm CST, Mon-Friday

Review complete warranty policy and register your product at:

**[www.deezee.com](http://www.deezee.com)**



## Dee Zee Job Box Installation Instructions

***Congratulations on your purchase of a quality Dee Zee product. Dee Zee is recognized as having the highest quality running boards and accessories on the market today. We have earned this reputation by offering our customers a product they can be proud to place on their vehicles. Dee Zee meets all the criteria of manufacturing a custom-fit product which guarantees it to be the easiest product to install.***

**Note: Please take time to read all of the instructions before beginning this installation.**

### **RECOMMENDATION:**

- Do not put fuels, flammables, explosives, or hazardous materials inside this product.
- Gasoline, solvents, gun powder or other munitions, dynamite, propane, acetylene, or other such products can explode if stored inside this product.
- Use these products only for storing and transporting electric or hand tools and equipment, and other similar materials.
- Failure to follow these warnings or modifications or other uses of this product could result in death, serious injury or property damage.
- Keep hands clear when closing the lid. Failure to do so could result in severe injury.

**If you should happen to have any questions with this product or you have an installation question, please feel free to call us at:**

**1-800-779-8222**

**If you would like to find out more information on Dee Zee's products, please feel free to visit our website at:**

**WWW.DEEZEE.COM**

## DZ 6036 / DZ 6048 / DZ 6060 Job Box

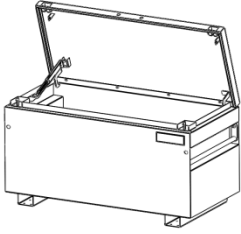
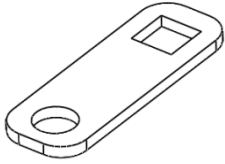
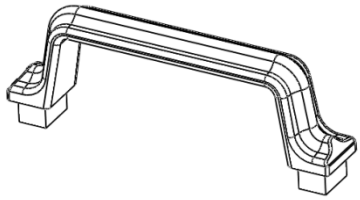
<div style="border: 1px solid black; padding: 2px; display: inline-block;"><b>A</b></div> <b>Job Box</b>    <b>VARIOUS</b> <span style="float: right;"><b>X1</b></span>	<div style="border: 1px solid black; padding: 2px; display: inline-block;"><b>B</b></div> <b>Padlock Shackle Bracket</b>    <b>B 1771</b> <span style="float: right;"><b>X2</b></span>	<div style="border: 1px solid black; padding: 2px; display: inline-block;"><b>C</b></div> <b>Lid Handle</b>    <b>TB85629</b> <span style="float: right;"><b>X1</b></span>
--	---	---

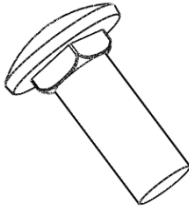
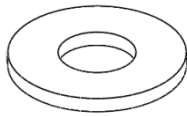
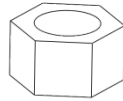
<div style="border: 1px solid black; padding: 2px; display: inline-block;"><b>D</b></div> <b>3/8" Square Neck Carriage Bolt</b>    <b>PN 317</b> <span style="float: right;"><b>X2</b></span>	<div style="border: 1px solid black; padding: 2px; display: inline-block;"><b>E</b></div> <b>3/8" Flat Washer</b>    <b>PN 113</b> <span style="float: right;"><b>X2</b></span>	<div style="border: 1px solid black; padding: 2px; display: inline-block;"><b>F</b></div> <b>3/8" Nut</b>    <b>PN 90B</b> <span style="float: right;"><b>X2</b></span>
--	--	--

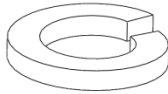
<div style="border: 1px solid black; padding: 2px; display: inline-block;"><b>G</b></div> <b>3/8" Lock Washer</b>    <b>PN 89B</b> <span style="float: right;"><b>X2</b></span>		
--	--	--

**Tools Required**

Ratchet or Wrench  
9/16"

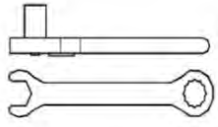

**1**

Your job box is designed to work with Masterlock No. 5 or American Lock No. 50 padlocks (not included). If you are using a lock other than those specified above, the lock needs to fit the following specification:

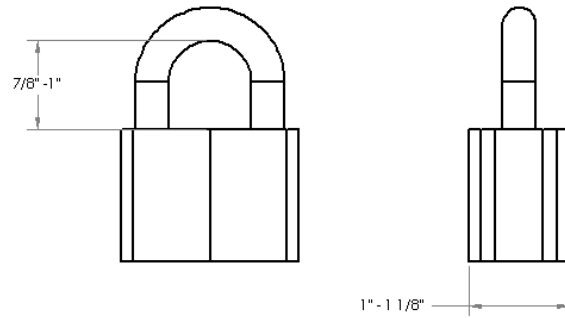

Slide the padlock shackle into the round hole in Item (B). Insert the padlock into the opening at the corner of the lid bracket first.

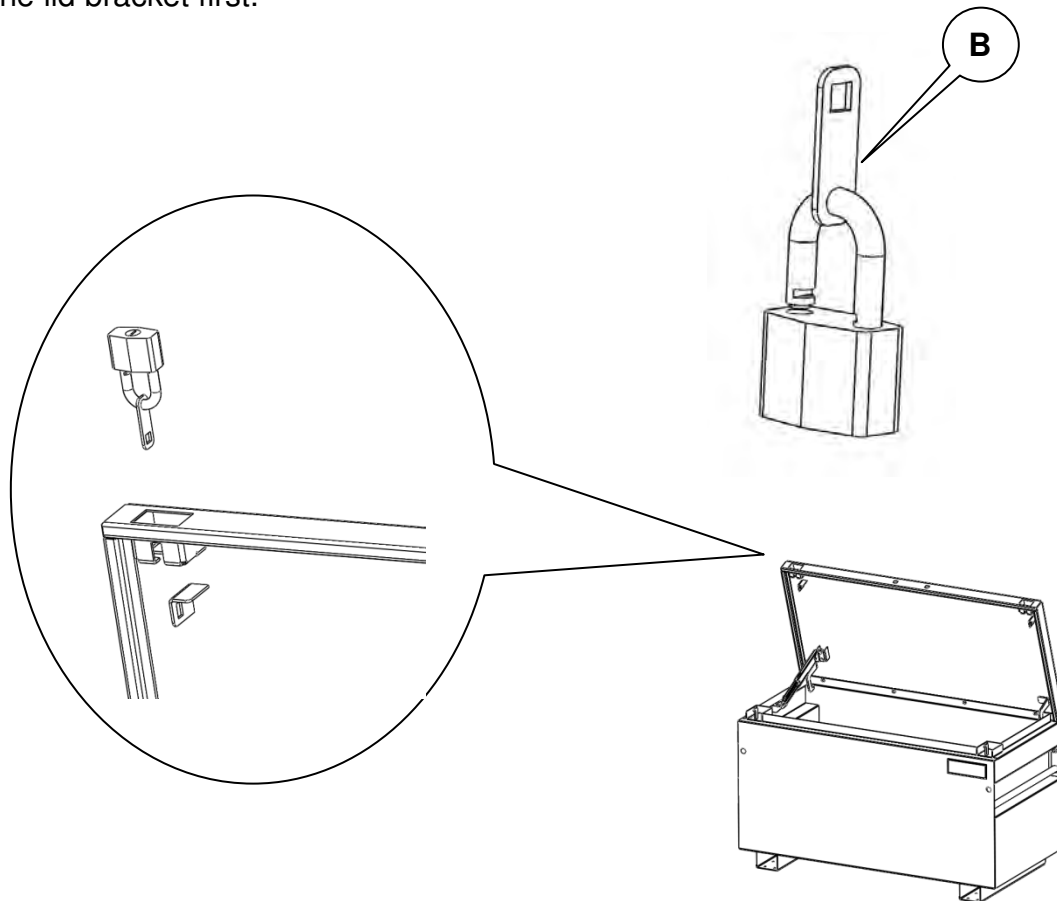

**2**

Attach the bracket to the mounting location using a square neck carriage bolt, washer, lock washer, and nut. Tighten the nut using a 9/16" wrench or ratchet. Close the lid of the job box and engage the pad lock. If the lock position is not correct, open the lid, loosen the nut and slide the bracket forward or backwards as necessary. Tighten the nut and recheck the lock position.

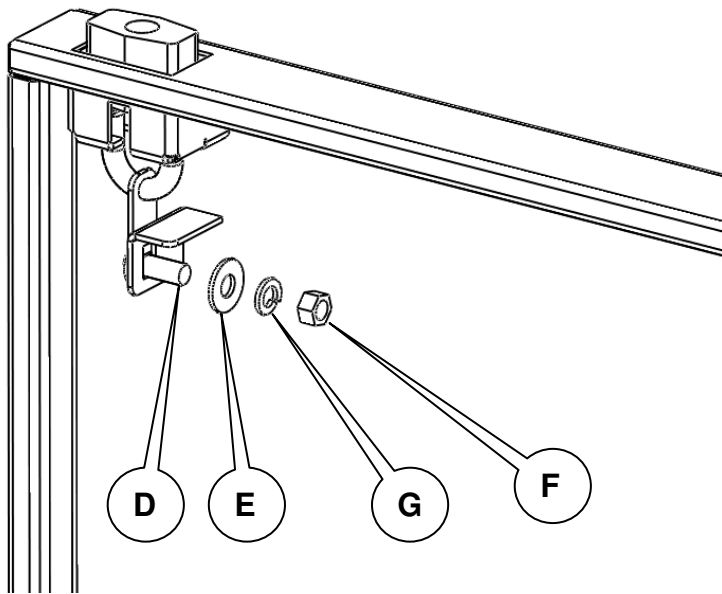

Once the padlock engages and locks the job box, repeat the padlock installation on the other end.

**3**

Align the handle (Item C) with the rectangular holes in the middle of the lid. Press the handle into place using a rubber mallet if necessary.

