



**Before returning this product
to the store of purchase**

Contact Dee Zee if you experience the following problems:

- Missing Parts
- Installation Problems/Questions
- Warranty Questions

1.800.779.2102

Hours of operation: 8am - 5pm CST, Mon-Friday

Review complete warranty policy and register your product at:

www.deezee.com



Dee Zee Toolbox Installation Instructions

Congratulations on your purchase of a quality Dee Zee product. Dee Zee is recognized as having the highest quality running boards and accessories on the market today. We have earned this reputation by offering our customers a product they can be proud to place on their vehicles. Dee Zee meets all the criteria of manufacturing a custom-fit product which guarantees it to be the easiest product to install.

Note: Please take time to read all of the instructions before beginning this installation.

Note: Use J-Bolt provided or **WARRANTY IS VOID...DO NOT USE** self tapping screws to mount.

Warning! If it is necessary to drill any holes into the vehicle, Dee Zee recommends putting a sealant or rust inhibitor around all holes drilled into the body of the vehicle.

Cleaning Instructions: To maintain the bright finish of your Dee Zee Stainless Steel Toolbox, clean with a mild detergent and then apply a high grade automotive type wax.

If you should happen to have any questions with this product or you have an installation question, please feel free to call us at:
1-800-779-8222

If you would like to find out more information on Dee Zee's products please feel free to visit our website at:
WWW.DEEZEE.COM

Platinum Toolbox

Installation Instructions

DZ 91730 / DZ 91733 / DZ 91736

DZ 91737 / DZ 92729 / DZ 92730

A

Platinum Toolbox:

Toolbox lid design may vary from picture with different toolbox models.

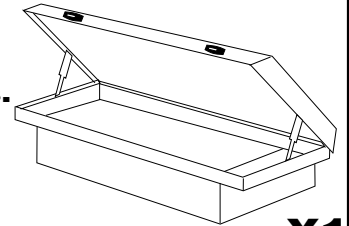

X1

B 3/8" J-Bolt

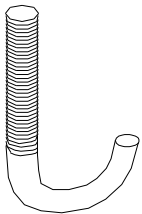

X4

C Washer

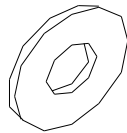

X4

D Hex Nut



X4

F Foam Tape

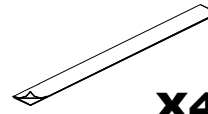

X4

G Toolbox Tray

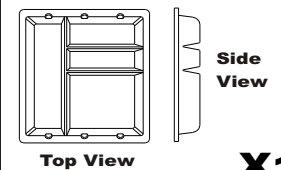

X1

H Net Clip

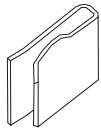

X11

I Net

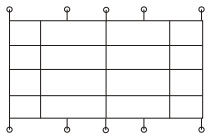

Tools Required:
Outils Nécessaires:

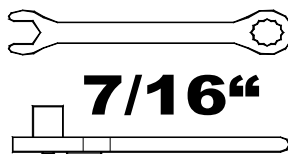

7/16"

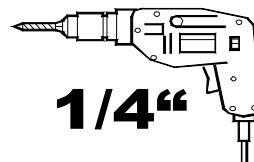

1/4"

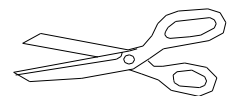

1

Peel backing off of foam tape (F).

Dégagement de peau de la bande de mousse (f).

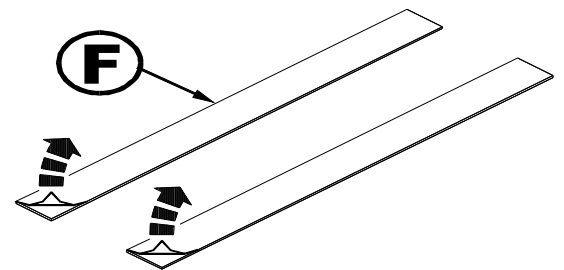

2

Place foam gasket (F) onto the bottom of toolbox (A). Trim the foam gasket (F) flush with the ends of toolbox (A).

Placez la garniture de mousse (f) sur le bas de la boîte à outils (a). Équilibrez l'éclat de la garniture de mousse (f) avec les extrémités de la boîte à outils (a).

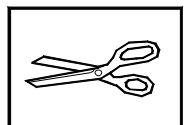
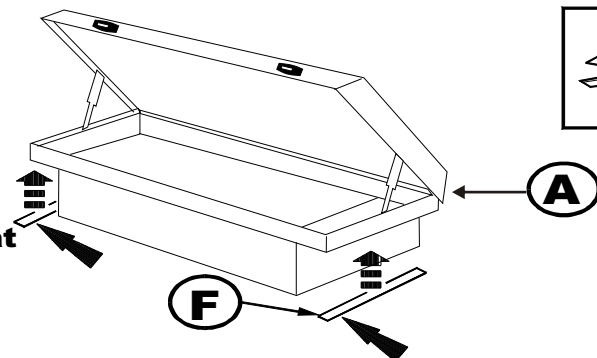

3

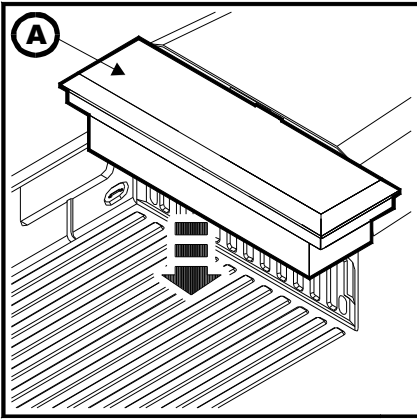

Place toolbox (A) into the back of your truck bed.

Placez la boîte à outils (a) dans le dos de votre lit de camion.

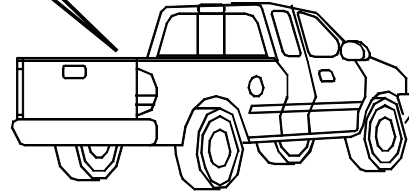

4

Using Drawing A and B below as a guide, mark the mounting hole locations for J-hooks (B). The mounting hole locations should be centered inside the toolbox (A) and near the lip of the truck bed rail as shown below.

En utilisant A et B de dessin ci-dessous comme guide, marquez les emplacements de trou de support pour les crochets en J (b). Les emplacements de trou de support devraient être centrés à l'intérieur de la boîte à outils (a) et s'approcher de la lèvre du rail de lit de camion comme montré ci-dessous.

Drawing A

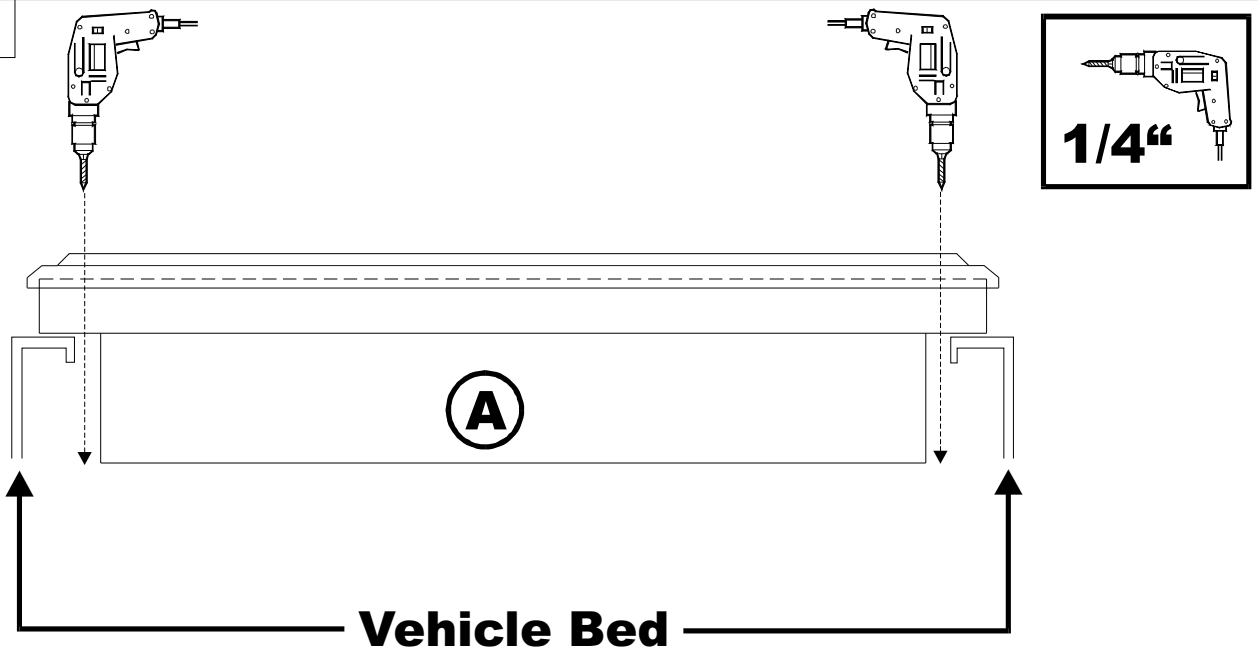

Drawing B

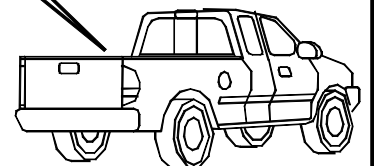
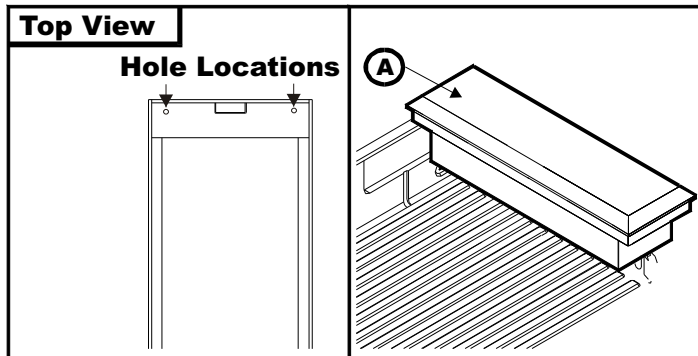

5

Secure toolbox (A) to the vehicle truck bed using J-bolts (B), flat washers (C), and hex nuts (D).

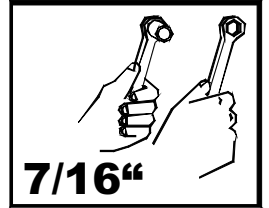

Fixez la boîte à outils (a) au lit de camion de véhicule en utilisant les boulons en J (b), à plat les rondelles (c), et les écrous de hexa (d).

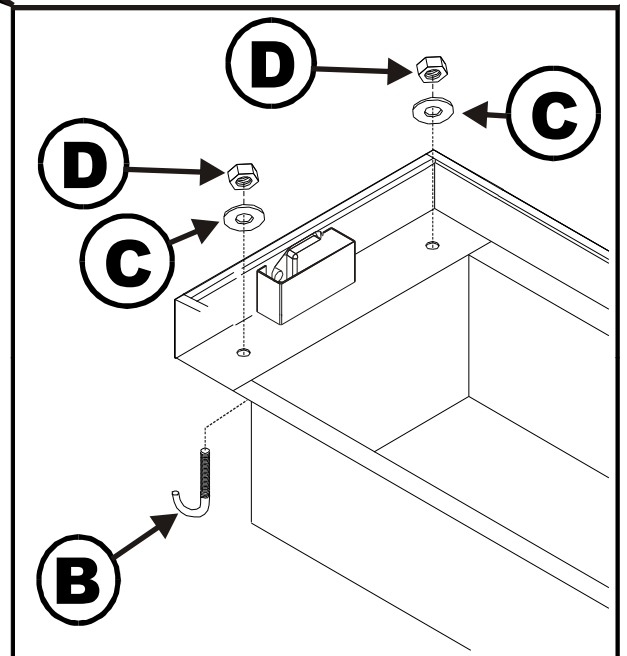
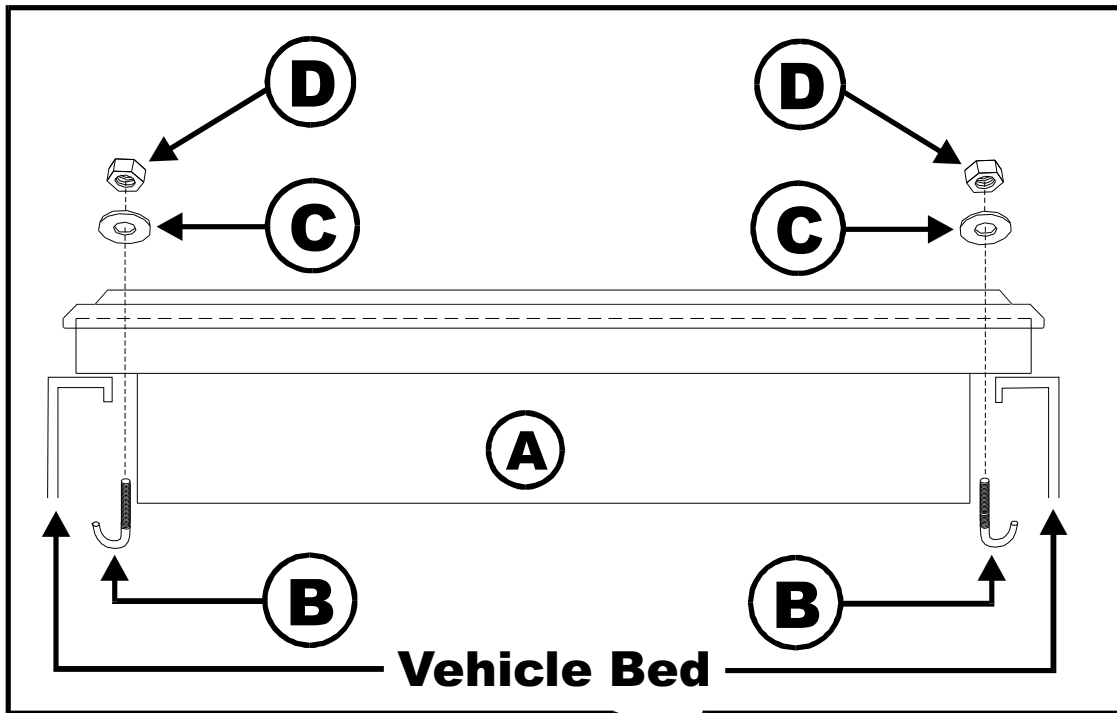

6

Place plastic plugs (E) into the holes in the bottom of toolbox (A).

Placez les prises de plastique (e) dans les trous dans le bas de la boîte à outils (a).

MAINTENANCE INSTRUCTIONS: All locks, latches, latching rods, and hinges should be lubricated regularly to assure smooth and proper operation for the life of the toolbox.

INSTRUCTIONS D'Entretien: Toutes les serrures, verrous, verrouillant des tiges, et des charnières devraient être lubrifiées régulièrement pour assurer l'exécution sans heurt et appropriée pendant la vie de la boîte à outils.

Toolbox Latch Adjustment

The latch system has been adjusted at the factory for a proper seal. However, due to shipping and handling or normal wear and tear, some adjustments may be needed.

Note: The Rotary Latch has two locking positions. When making the necessary adjustments the latch must lock in the second position for a proper seal.

Horizontal Adjustment:

The horizontal adjustment is rarely needed. However, if needed, follow these steps:

- 1) Use a 3/8" wrench to loosen the four horizontal adjustment bolts, so that the Rotary Mounting Bracket will slide.
- 2) Slide the Rotary Mounting Bracket to the proper position. Make sure that the center of the Rotary Mounting Bracket lines up with the center of the striker bolt located on the body.
- 3) Make sure that the Rotary Mounting Bracket is level with the platinum toolbox lid, before tightening the four horizontal adjustment bolts.
- 4) After the Rotary Mounting Bracket is secure, make sure that 1/8" to 3/16" gap is maintained between the lock nuts and the eye nut. This will prevent the latch from opening when in the locked position.

Note: After the above adjustments are made, make sure that the latches and lock function correctly before shutting the lid.

Vertical Adjustments:

- 1) Use a 3/8" wrench to loosen the four vertical adjustment bolts so that the Rotary Latch will slide.
- 2) Adjust the Rotary Latch up to tighten or down to loosen the lid.

Note: If the Rotary Latch is moved in the up position to tighten the platinum toolbox lid too much, the latch may not lock in the second position.

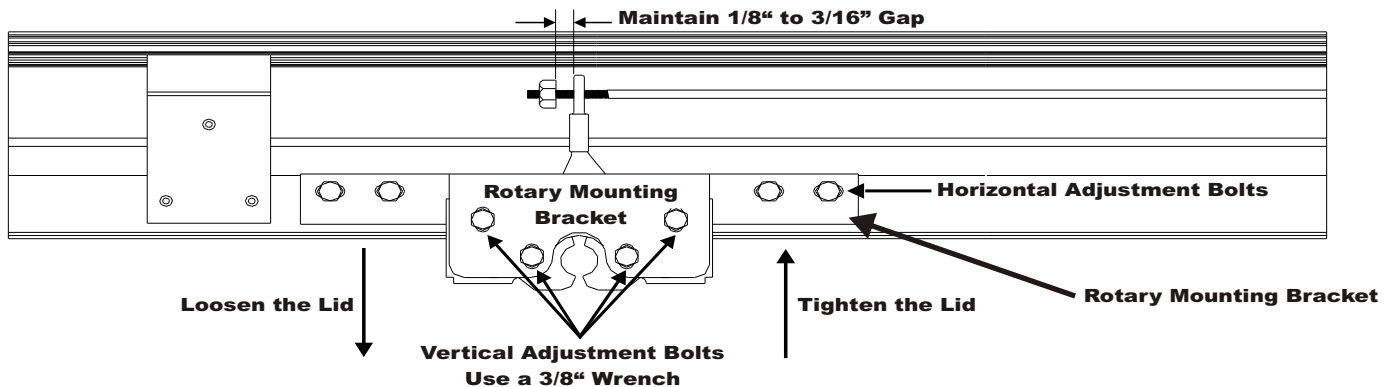

Ever lose your keys? Save Yourself Time and Trouble?

Order some extra keys now and have them when you need them. Please fill out and mail this portion to us. We'll send you a couple of extra keys for your Tool Box for just \$11.00 (American).

Name: _____

Day Phone: _____ - _____ - _____

Address: _____

Method of Payment:

Cash, Check, or Money Order

Master Card

Visa

City, State, Zip: _____

Expiration Date: _____

KEY and LOCK#: _____

Card Number: _____

Please mail form and payment to : Dee Zee, Inc.
OR P.O. Box 3090
Fax to: 515-265-7926 Des Moines, IA 50316

CLEANING INSTRUCTIONS: To maintain the luster of your tool box, use a mild detergent.

****Locks are provided as a deterrent to inadvertent opening or easy access to the contents of your toolbox. Contents stored in the toolbox are the responsibility of the user.**

After drilling, it is recommended that a sealant or rust inhibitor be placed around all holes drilled into the body panel of the vehicle.

If you should incur any problems with the installation of this product, please feel free to call us at 1-800-779-8222.