

INSTALLATION SHEET

FULLTILT

SNAPLESS SMOOTH EDGE

extang
AMERICA'S BEST
SELLING TONNEAUS

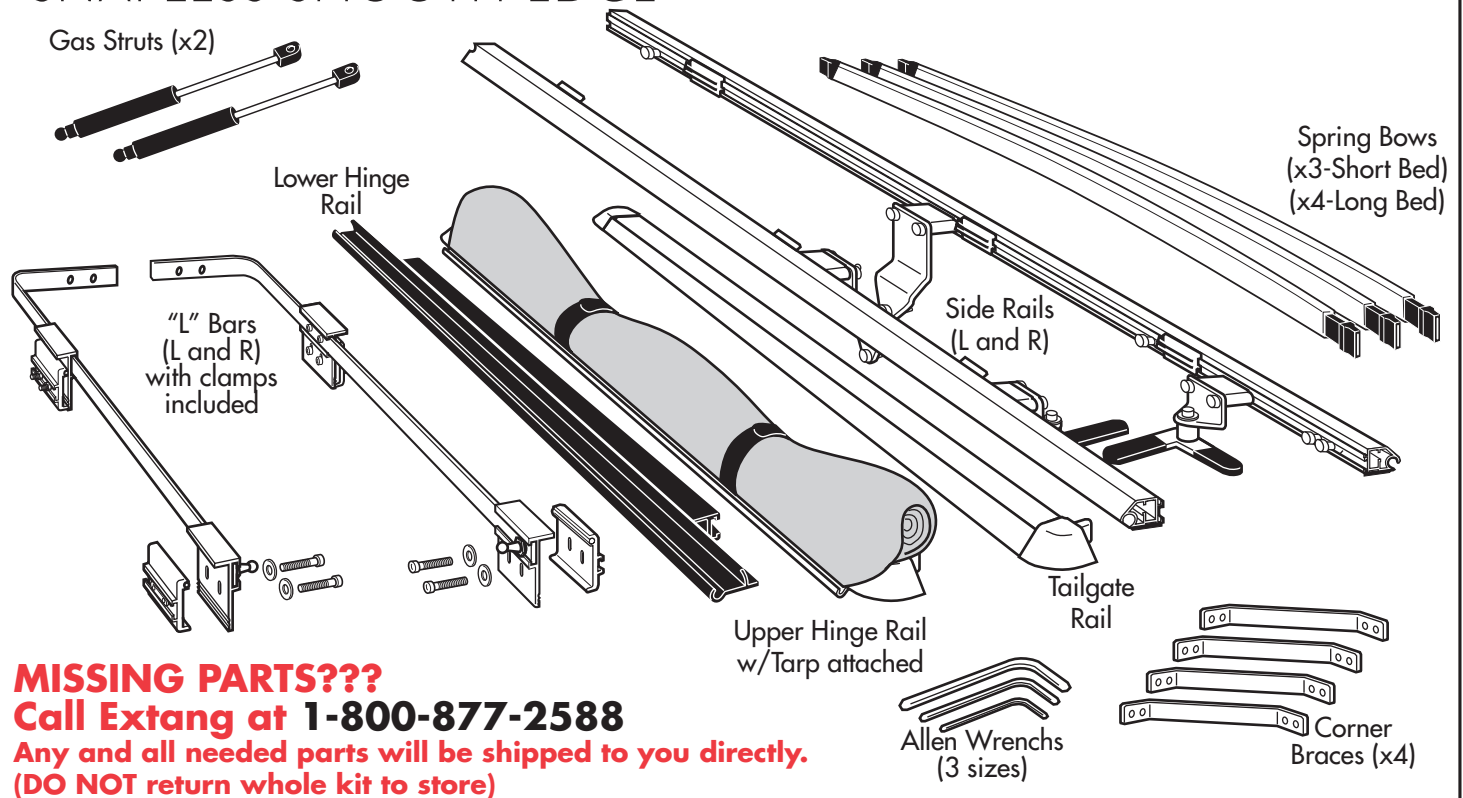

MISSING PARTS???
Call Extang at 1-800-877-2588
Any and all needed parts will be shipped to you directly.
(DO NOT return whole kit to store)

PARTS INCLUDED IN YOUR KIT. You may want to lay them out in this manner for accessibility.

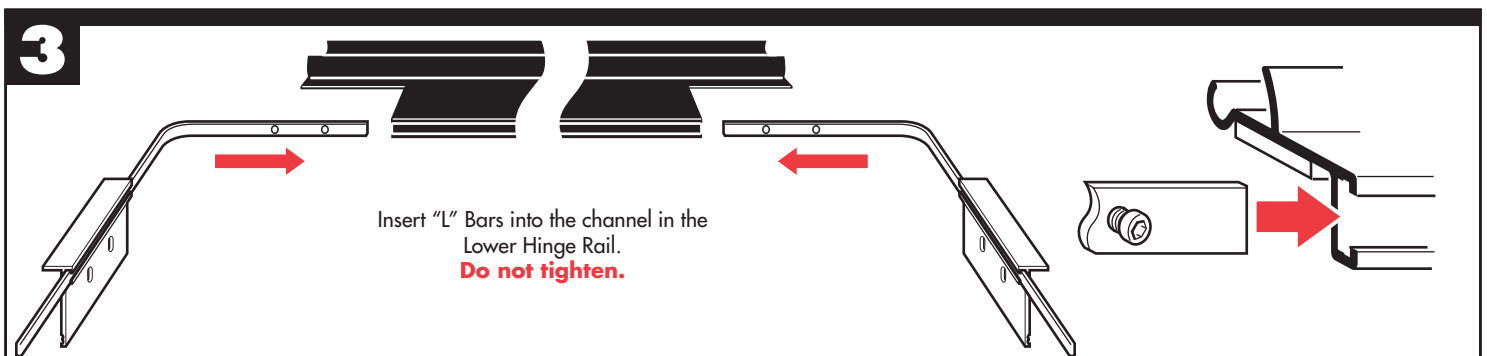

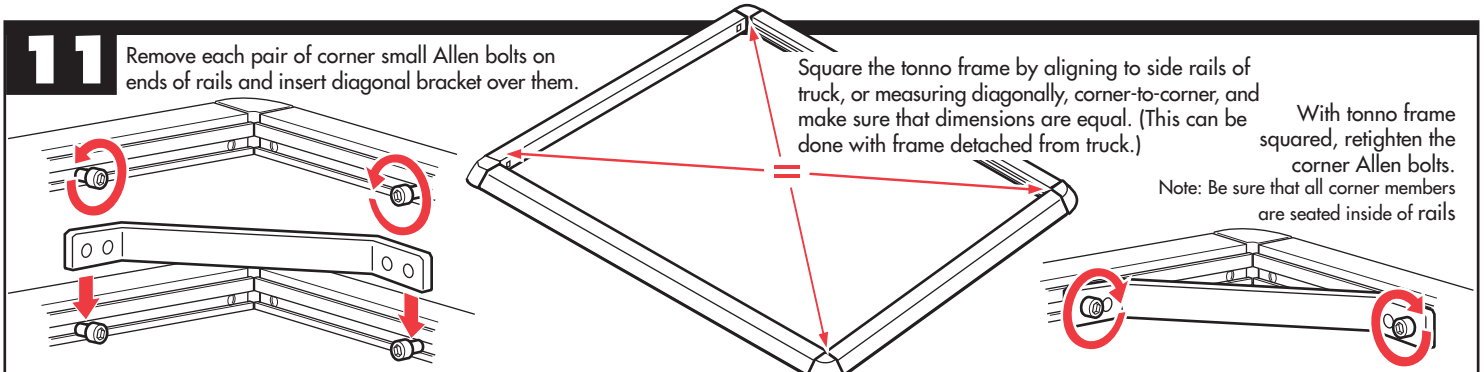
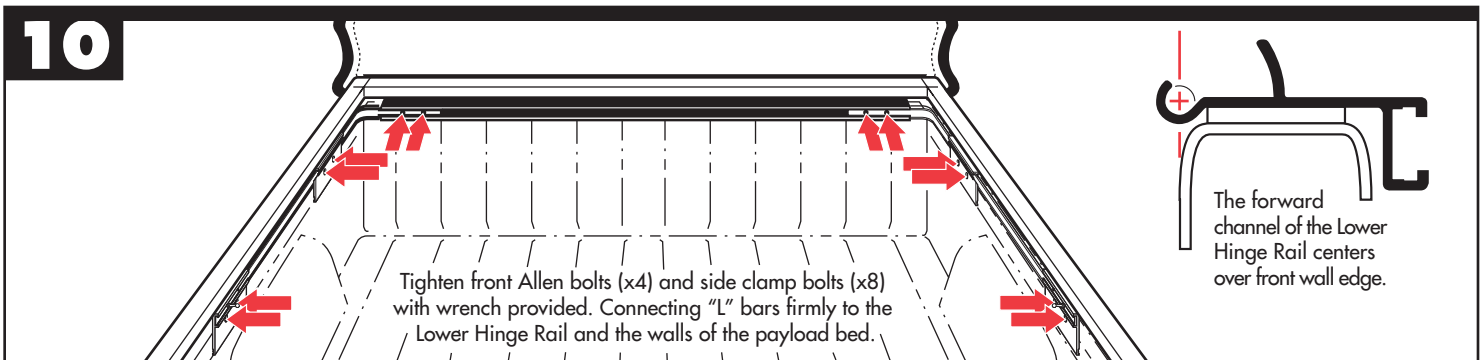
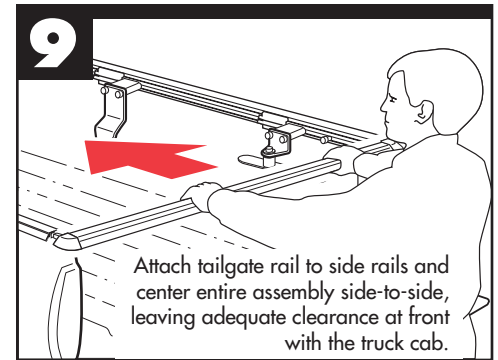
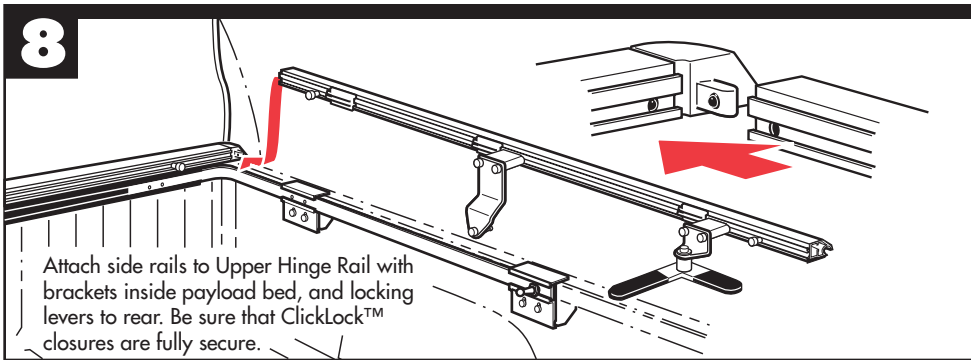
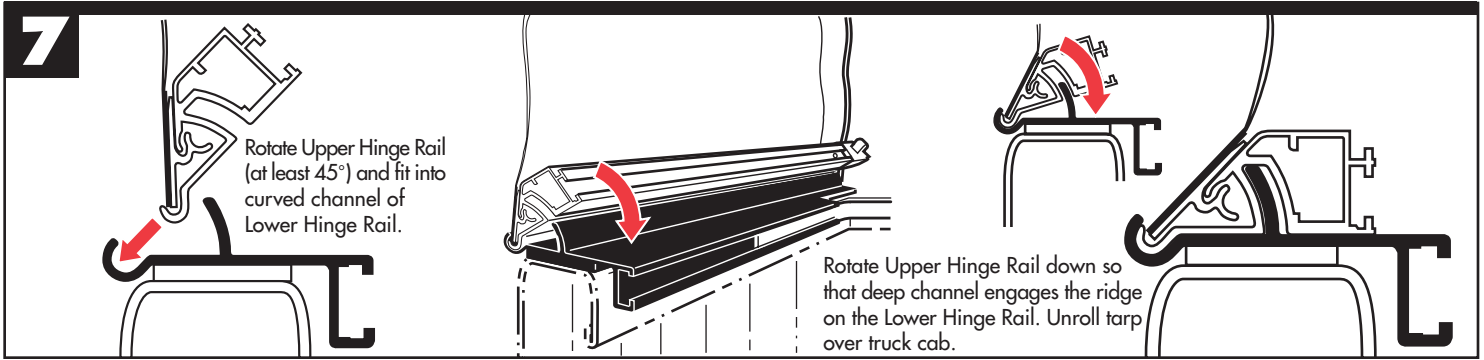
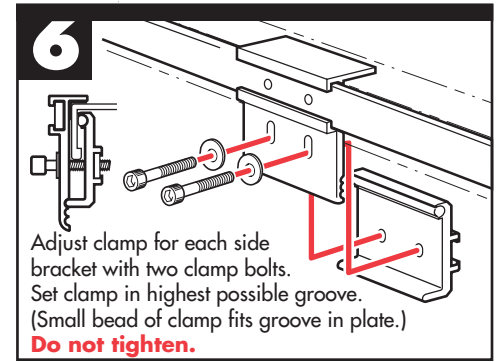
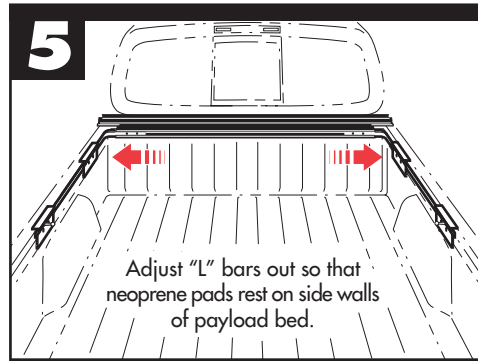
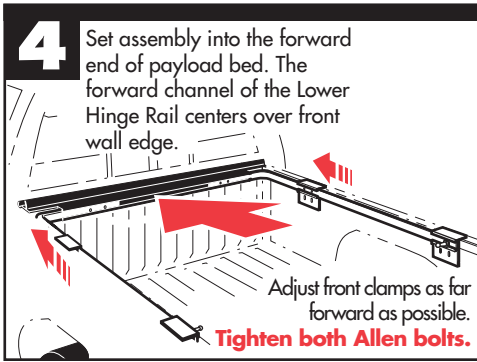

12

Frame Locking Lever must be parallel to side rail when opening and closing tonno.

Locking Lever is secure when positioned at right angle to, and engaged with side wall.

Locking Levers come from the factory ready to fit your truck.

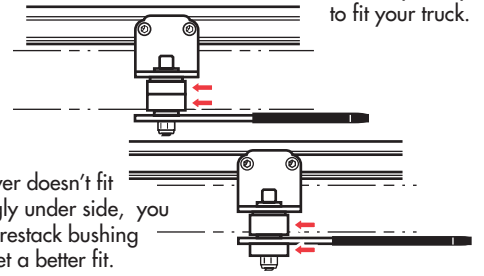
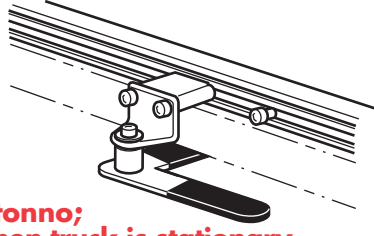
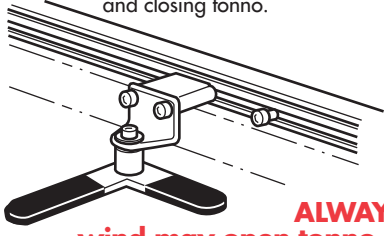

ALWAYS latch tonno; wind may open tonno, even when truck is stationary.

If lever doesn't fit snugly under side, you can restack bushing to get a better fit.

13

Insert bow onto top or bottom peg, (Top peg for performance, Bottom for good looks.)

Ends are spring loaded for easy installation. Push and hold on spring end and let the other end slide on with the spring action. **NOTE: Center bow provides support to side rails and may seem tight when inserting between side rails. It may be necessary to pull out on side rails to install the center bow.**

Upper Peg

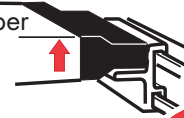

or

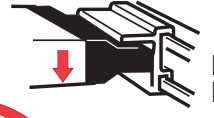

Lower Peg

SPECIAL FEATURE: Two pegs offer two height adjustments. Note: Bow End does not fit between pegs.



Do Not Place Between the Pegs

14

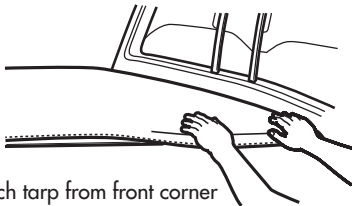

A. Attach tarp from front corner (12 inches) Repeat for each side.

Note: Pull tarp out while pressing down in center of the side strip to flex hook open for easy attachment.

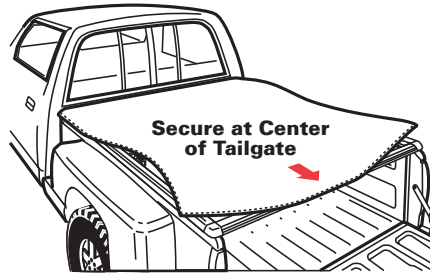

B. Secure tarp at the middle of tailgate rail.

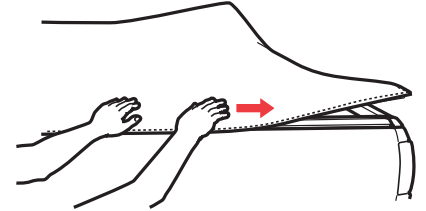

C. Finish attaching tarp along each side by pushing down and sliding your hand front to rear, and on tailgate rail, by pressing out from the center.

15

Place sockets of Gas Strut over ball joints on each bracket (cylinder-end attaches to truck). Cylinder (round) socket should press easily over the lower ball. Press retainer of upper socket into the ball to lock securely in place. To remove cover from truck, disengage Gas Strut at lower joint only.

NOTE: Round socket will release with hand pressure. Do not remove strut from tonno frame.

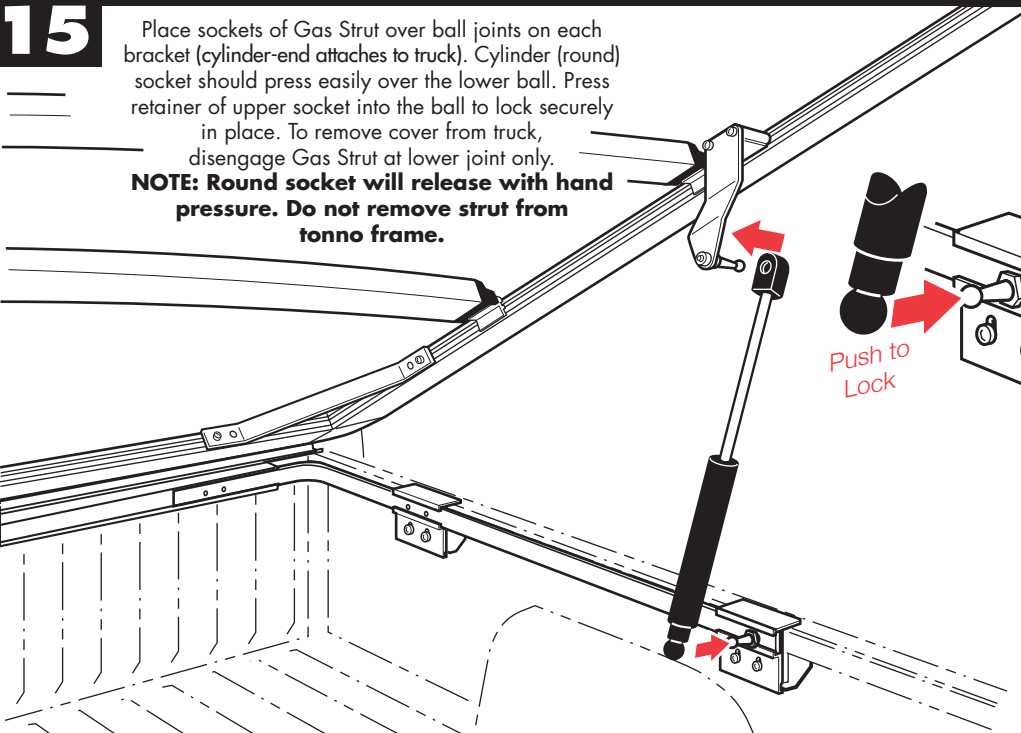

Push to Lock

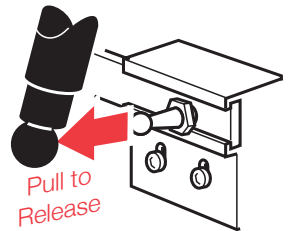
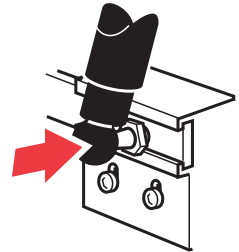

Pull to Release



Operating Your FullTilt™ SL Tonno

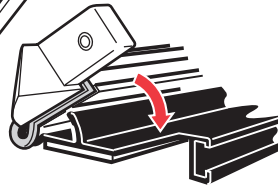
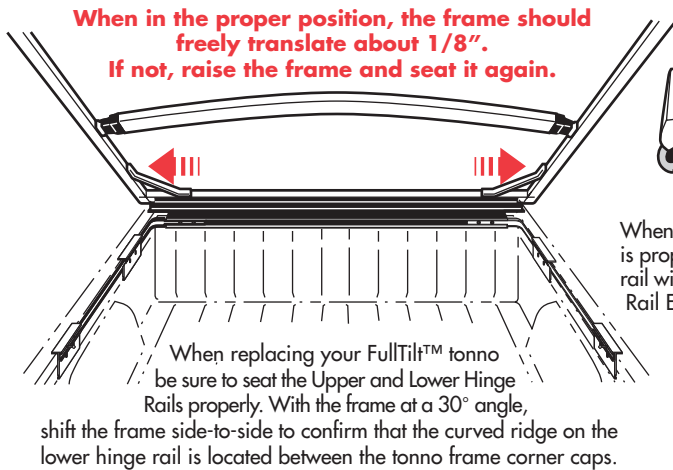

When the Upper Hinge Rail Assembly is properly centered side to side—the rail will rotate easily. Be sure that steel Rail End Plates are in place to keep rails from jamming.



Make sure that Upper Hinge Rail Assembly slides easily over ridge on Lower Hinge Rail.

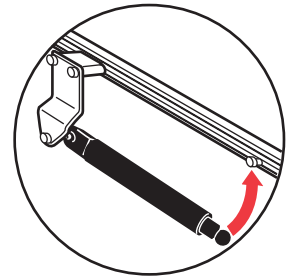

When tonno is removed, stow the gas shock against the shock hold down stud.

Quick Tips

- Do not overload your truck bed. Objects that press into the vinyl will wear a hole quite quickly. If you need to carry larger objects, remove the entire tonneau frame, or roll the tarp to the cab and secure. However when the tarp is rolled up the tail rail must be attached to the framework.
- If the load is too large to accommodate the tail rail, then the tonneau frame and tarp must be completely removed. Reassemble when load is removed. The tonneau can be easily stowed and reassembled for the return trip. It will improve your fuel economy all the way home!
- Do not attempt to carry the assembled tonneau loose in the truck bed, even for a short distance, and even if tied down. The tonneau will try to become airborne even at low speeds.

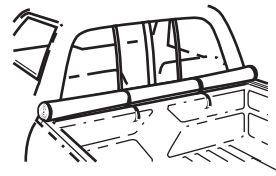

If you need to tow your vehicle backward, be sure to release the cover and stow against the hinge rail using Velcro® straps provided.

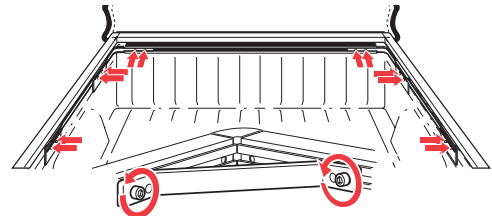

On a periodic basis, you should check the security of all the fasteners on your tonneau system. Trucks driven on bumpy roads or at high speeds suffer vibration that can loosen all elements of your tonneau system.

WARNING!

High winds may catch the tonno cover and cause it to open if not latched. Be very careful raising tonno in windy conditions. Cover should always be latched when down. Do not drive with cover raised or unlatched, even at slow speeds. When towing vehicle backwards, cover must be removed or tarp fully rolled and secured with Velcro® straps.

Quick and Easy Removal

- Step 1- Lift and hold cover while releasing the lower joint of the gas strut.
- Step 2- Rotate the cover upward past 45° and lift out of the quick-hinge front rail system.
- Step 3- Slide off the Lower Hinge Rail.

Quick and Easy Reattachment

- Step 1- Lift cover as a unit and drop front edge into the quick-hinge front rail system groove. Be careful that locking tongue (vertical web) is between both corner pieces and Rail End Plates. There is about 1/8' total clearance on the ends. Slowly and gently rotate downward. **DO NOT FORCE! IT SHOULD FALL INTO PLACE!!** Note: Frame should slide side-to-side about 1/8" freely, if hinge is tight, something is wrong, you are most likely not centered.
- Step 2- Reattach the gas struts with body on bottom in open position. Drop cover and latch both sides securely.