

2360 Boswell Road
Chula Vista, CA 91914
Phone 619.216.1444
Fax 619.216.1474
E-Mail tech@explorerprocomp.com



PRO COMP SUSPENSION

Suspension Systems that Work!

**Part# 52440
2005 FORD SUPER
DUTY 4WD DOUBLE
SHOCK HOOP KIT**

NOTE: This kit is to be used in conjunction with Pro Comp Lift Kits Only!

This document contains very important information that includes warranty information and instructions for resolving problems you may encounter. Please keep it in the vehicle as a permanent record.

Box 1 of 2-PN 52440 -1

Part #	Description	Qty.	Illus.	Page
90-2515	DOUBLE SHOCK HOOP- (Drvr)	1	1	6
90-2517	DOUBLE SHOCK HOOP- (Pass)	1	2	6
90-3219	LOWER MT. BRACKET- (Drvr)	1	3,4	7
90-3224	LOWER MT. BRACKET- (Pass)	1	-	-
90-3383	UPPER SWAY BAR DROP PLATE-Pass	1	-	-
90-3382	UPPER SWAY BAR DROP PLATE-Driver	1	8,9,10	10,11
90-2548	SWAY BAR DROP BLOCK	2	9,10	10,11
90-3251	LOWER SWAY BAR ADAPTER BRACKET	2	3,4,11	7,11
90-6400	HARDWARE PACK: Double Shock Hoop	1	-	-
70-0502751800	1/2" X 2 3/4" GR. 8 HEX BOLT	8	7	9
70-0501501800	1/2" X 1 1/2" GR. 8 HEX BOLT	3	1,2	6
72-050100816	1/2" STOVER NUT	10	1,2,7	6,9
73-050000830	1/2" SAE FLAT WASHER	21	1,2,7	6,9
72-056100812	9/16" NYLOC NUT	2	3,4	7
73-05600830	9/16" SAE FLAT WASHER	2	3,4	7
70-0371251800	3/8" X 1 1/4" GR. 8 HEX BOLT	4	1,2	6
72-037100816	3/8" STOVER NUT	4	1,2	6
73-03700830	3/8" SAE FLAT WASHER	8	1,2	6
70-0437501800	7/16" X 7 1/2" GR. 8 HEX BOLT	2	5	8
72-043100816	7/16" STOVER NUT	2	5	8
73-04300830	7/16" SAE FLAT WASHER	4	5	8
90-6403	HARDWARE PACK- Limit Strap Adjuster	1	-	-
90-4123	LIMIT STRAP ADJUSTER	2	6	8
90-4122	ADJUSTER NUT	2	6	8
62FNFJZ	5/8" JAM NUT	2	6	8
73-06200034	5/8" HARDENED WASHER	2	6	8
90-6419	HARDWARE PACK: Limit Strap	1	-	-
70-0501751807	1/2" X 1 3/4" GR.8 ALLEN HEAD BOLT	2	6	8
72-050100816	1/2" GR. 8 STOVER NUT	2	6	8
73-050000830	1/2" FLAT WASHER	4	6	8
90-6405	HARDWARE PACK: Shock Hardware	1	-	-
90-2521	SPACER 1.375"	2	3,4	7
90-6271	HARDWARE PACK- End Caps	1	-	-
15-11213	1 1/2" END CAP	4	1,2	6
5223-1	LIMIT STRAP-22"	2	3,4	7
90-2569	BUMP STOP EXTENSION CUP	2	5	8

90-1582	NUT PLATE	1	6	2
90-6451	HARDWARE PACK: Sway Bar Mounts	1	-	-
70-0432251800	7/16" X 2 1/4" GR. 8 HEX BOLT	4	9	10
70-0431501800	7/16" X 1 1/2" GR. 8 HEX BOLT	4	9	10
72-043100816	7/16" STOVER NUT	8	9	10
73-04300834	7/16" HARDENED FLAT WASHER	16	9	10
70-0503001800	1/2" X 3" GR. 8 HEX BOLT	2	9	10
73-05000830	1/2" SAE FLAT WASHER	4	9	10
72-050100812	1/2" NYLOC NUT	2	9	10
90-6418	HARDWARE PACK: 9/16" Nut Plate	1	-	-
70-0563501800	9/16" X 3 1/2" GR. 8 HEX BOLT	2	3,4	7
73-05600830	9/16" SAE FLAT WASHER	2	3,4	7
90-3267	9/16" NUT PLATE	2	3,4	7
90-6413	HARDWARE PACK: Sway Bar Link	1	-	-
90-1094	SWAY BAR LINK	2	11	11
54314	SLEEVE 1/2"	2	11	11
P-1036	SLEEVE 9/16"	2	11	11
600020	BUSHING	2	11	11
600000	BUSHING	2	11	11
90-6428	HARDWARE PACK: Bushings and Sleeves	1	-	-
600000	5/8" URETHANE HOURGLASS BUSHING	2	-	-
54314	SHOCK SLEEVE 1/2" X 5/8" X 1"	2	-	-

Additional PRO COMP Equipment Required For installation!

925501	9000 SERIES FRONT SHOCKS	4*
or		
MX6129	MX-6 SERIES SHOCKS	4*
or		
MX6065R	MX-6 RESERVIOR SHOCKS	4*
* If reusing MX-6 or MX-6R front shocks only order 2 new shocks.		
or		
FX6506	FOX 2.0 RESERVIOR SHOCK BOX	1
or		
FX6303	FOX 2.0 EMULSION SHOCK BOX	1

Optional Equipment Available from your Pro Comp Distributor!

**22415 REAR LEAF SPRINGS,
LIGHTS,
227010 FACTORY REPLACEMENT STEERING STABILIZER,
219567 DUAL STEERING STABILIZER KIT,
52480 CARRIER BEARING SHIM KIT,
599 ALIGNMENT CAM KIT
50191 U-Bolt Kit
PN 72400 TRACTION BARS, PN 72099 MOUNTING KIT**

Also, check out our outstanding selection of Pro Comp tires
to compliment your new installation!

Introduction:

- ◆ **This installation requires a professional mechanic!**
- ◆ We recommend that you have access to a factory service manual for your vehicle to assist in the disassembly and reassembly of your vehicle. It contains a wealth of detailed information.
- ◆ Prior to installation, carefully inspect the vehicle's steering and driveline systems paying close attention to the tie rod ends, ball joints, wheel bearing preload, pitman and idler arm. Additionally, check steering-to-frame and suspension-to-frame attaching points for stress cracks. The overall vehicle must be in excellent working condition. Repair or replace all worn or damaged parts!
- ◆ Read the instructions carefully and study the illustrations before attempting installation! You may save yourself a lot of extra work.
- ◆ Check the parts and hardware against the parts list to assure that your kit is complete. Separating parts according to the areas where they will be used and placing the hardware with the brackets before you begin will save installation time.
- ◆ Check the special equipment list and ensure the availability of these tools.
- ◆ Secure and properly block vehicle prior to beginning installation.
- ◆ **ALWAYS** wear safety glasses when using power tools or working under the vehicle!
- ◆ Use caution when cutting is required under the vehicle. The factory undercoating is flammable. Take appropriate precautions. Have a fire extinguisher close at hand.
- ◆ Foot pound torque readings are listed on the Torque Specifications chart at the end of the instructions. These are to be used unless specifically directed otherwise. Apply thread lock retaining compound where specified.
- ◆ ***Please note that while every effort is made to ensure that the installation of your Pro Comp lift kit is a positive experience, variations in construction and assembly in the vehicle manufacturing process will virtually ensure that some parts may seem difficult to install. Additionally, the current trend in manufacturing of vehicles results in a frame that is highly flexible and may shift slightly on disassembly prior to installation. The use of pry bars and tapered punches for alignment is considered normal and usually does not indicate a faulty product. However, if you are uncertain about some aspect of the installation process, please feel free to call our tech support department at the number listed on the cover page. We do not recommend that you modify the Pro Comp parts in any way as this will void any warranty expressed or implied by the Pro Comp Suspension company.***

Installation:

1. Block rear wheels.
2. Raise and support front axle and frame with jack stands.
3. Remove the front wheels.
4. Unbolt the sway bar from the sway bar end links on both sides of the vehicle. Remove the end links and sway bar from the vehicle. Save for reinstallation.
5. Unbolt the lower brake line bracket and ABS clips from the lower coil block. Save hardware for reuse
6. Raise the front axle enough to relieve tension on the shock hardware and remove the shocks from the vehicle.
7. Lower the front axle enough to remove the coil springs from the front spring pockets. Save the factory isolators and springs for reuse.

NOTE: Be sure to support the axle while the springs and shocks are removed.

8. Work on one side of the vehicle at a time.
9. On the driver side, remove the front lower mounting bolt from the frame that connects the steering box to the frame.
10. Insert the shock hoop (90-2515) with the short arm of the hoop to the rear of the truck. Guide the center hole in the bracket to fit around the upper coil spring locator. Clamp the upper plate to the top of the coil bucket. Secure using the previously removed steering box bolt. See ILLUSTRATION 1.

NOTE: Use thread locker on the steering box bolt and start it by hand to ensure it goes in properly.

11. Drill out the existing rear mounting hole to 1/2". See ILLUSTRATION 1.
12. Bolt the hoop rear mounting tube to the frame using the supplied 1/2" X 1 1/2" bolt and hardware in the rear mounting hole. See ILLUSTRATION 1.

NOTE: You will have to reach through the hole in the frame opening to access the bolt from the back side.

13. Use the existing holes in the hoop bracket as a template to center punch the mounting holes in the coil bucket. See ILLUSTRATION 1.
14. Using a drill stop to prevent drilling through the inner fender, drill out the previously marked holes with a 3/8" bit.

CAUTION! Be very careful not to drill through the plastic inner fender and any wiring that may be attached to it.

15. Bolt the center bracket to the coil bucket using the supplied 3/8" X 1 1/4" bolts from pack (90-6400).

NOTE: Using a pry bar or large screwdriver to pry the inner fender up to aid in installing the nuts on the bolts.

16. On the passenger side, insert the shock hoop (90-2517) with the short arm of the hoop to the rear of the truck. Guide the center hole in the bracket to fit around the upper coil spring locator. Clamp the upper plate to the top of the coil bucket. See ILLUSTRATION 2.
17. Locate the rear hole and drill out the existing rear mounting hole to 1/2". See ILLUSTRATION 2.
18. Secure the rear of the shock hoop to the rear mounting hole using the supplied 1/2" X 1 1/2" bolt. See ILLUSTRATION 2.
19. Make sure the front mount is sitting flush against the frame and center punch and drill the front 1/2" mounting hole using the hoop front mount as a guide. See ILLUSTRATION 2.
20. Bolt the hoop mounting tubes to the frame using the supplied 1/2" X 1 1/2" bolt and the nut plate (90-1582) in the mounting holes. See ILLUSTRATION 2.

NOTE: The brake line bracket on the upper spring bucket will need to be temporarily

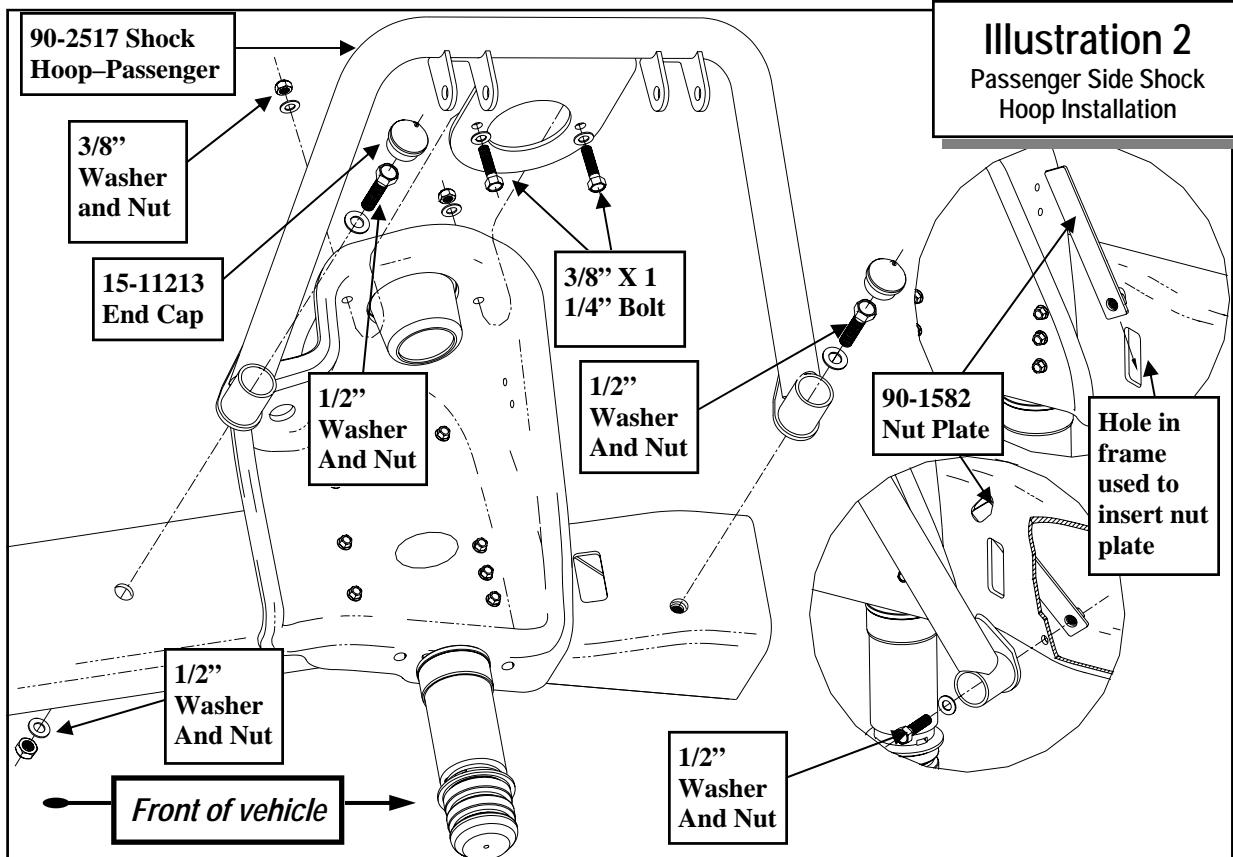
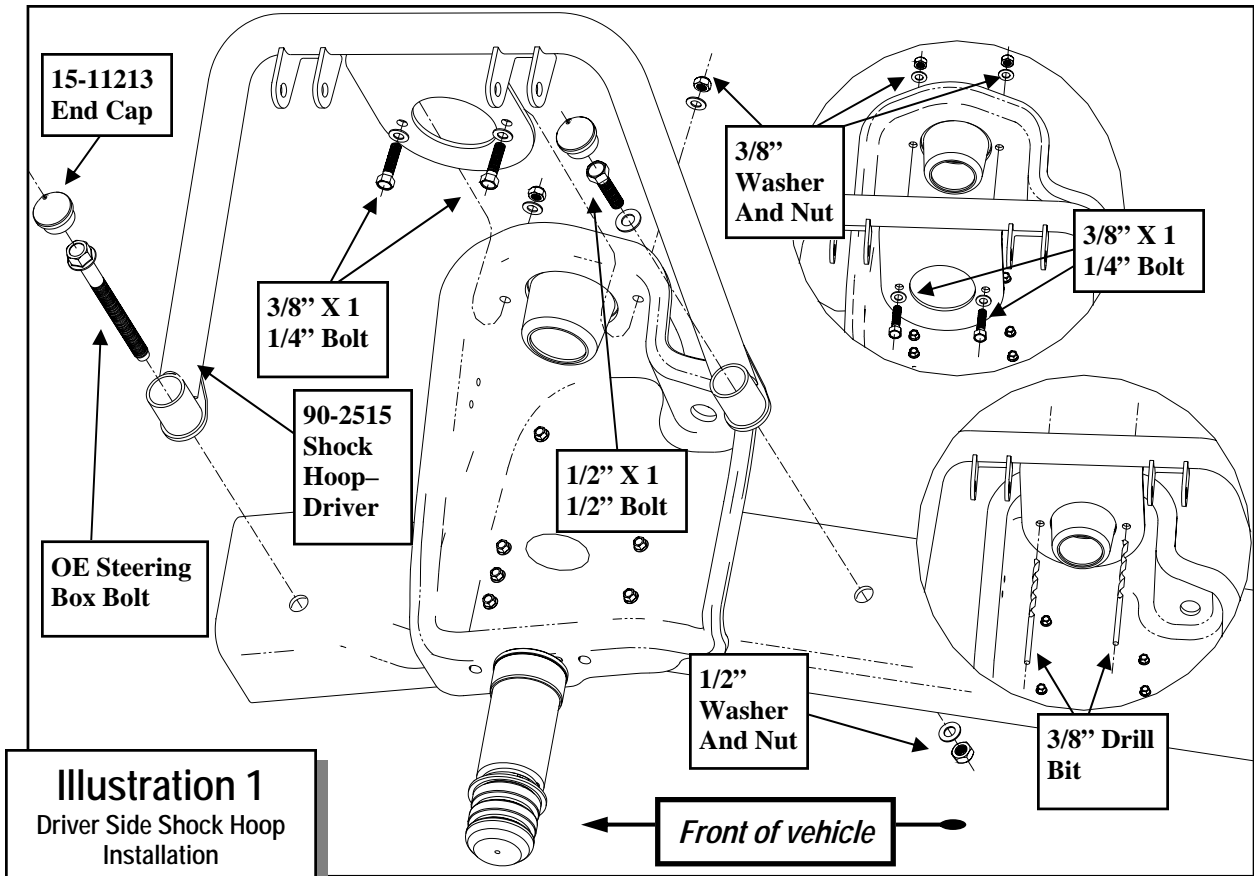

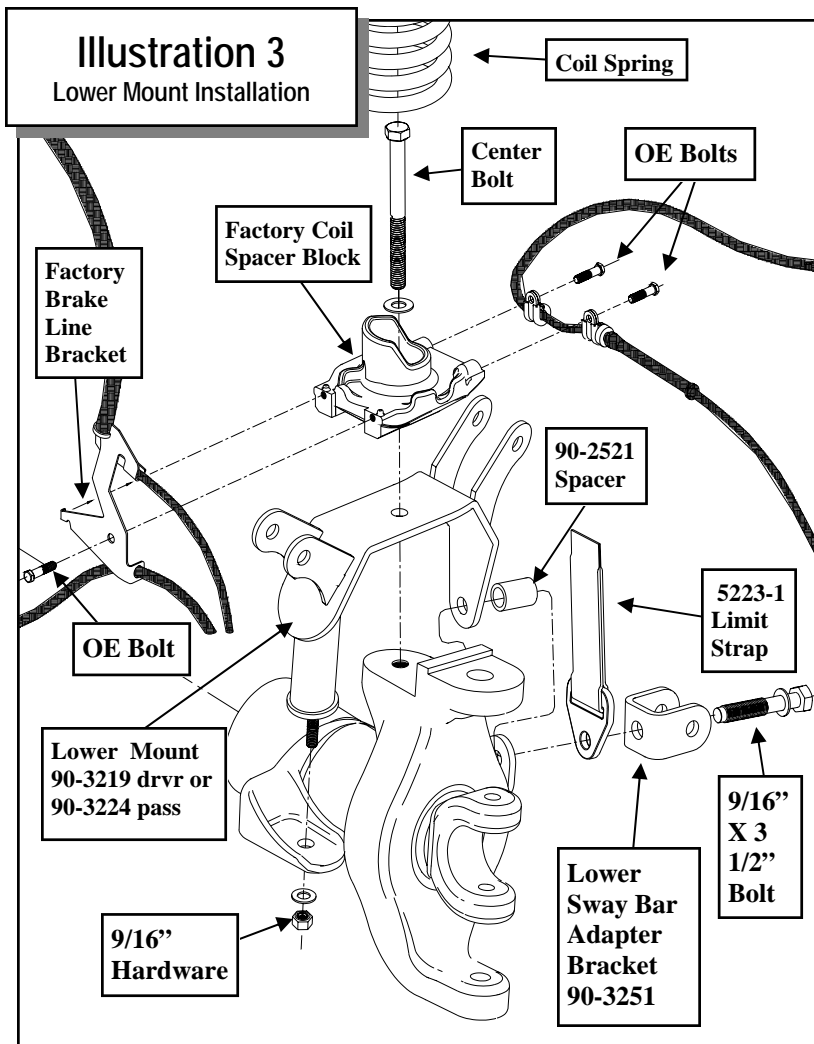

removed in order to access the hole in the frame to insert the nut plate.

21. Use the existing holes in the bracket as a template to center punch the mounting holes in the coil bucket.

22. Using a drill stop to prevent drilling through the inner fender, drill out the previously marked holes with a 3/8" bit. See ILLUSTRATION 1.

CAUTION! Be very careful not to drill through the plastic inner fender and any wiring that may be attached to it.

23. Bolt the center bracket to the coil bucket using the supplied 3/8" X 1 1/4" bolts. See ILLUSTRATION 2.

NOTE: Using a pry bar or large screwdriver to pry the inner fender up to aid in installing the nuts on the bolts.

24. Torque all hoop hardware as specified in the torque chart. Torque the hoop to frame mounts before the upper bracket mounts. Re-torque all (3) steering box bolts to 111 ft. lbs.

25. Install (15-11213)- 1 1/2" end cap in the end of the shock hoops. See ILLUSTRATION 1,2.

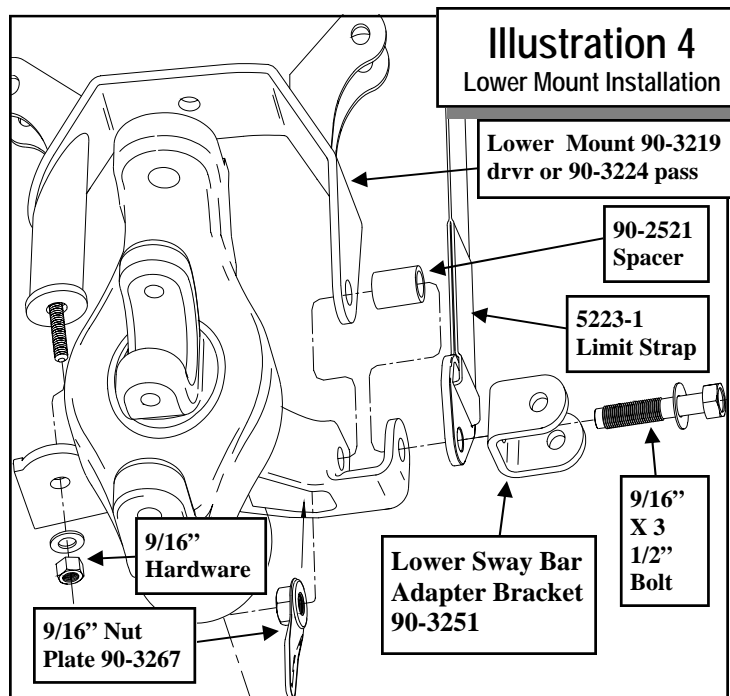

26. Working on one side of the vehicle at a time, remove the center bolt from the lower coil spring spacer block. See ILLUSTRATION 3.

27. Remove the coil spacer block and install the lower shock mounting bracket (90-3219 driver, 90-3224 passenger) to the axle.

NOTE: The side with the welded spacer tube with the stud goes toward the front of the vehicle in the previously removed sway bar mount hole.

28. Reinstall the factory coil spacer block and secure with the previously removed center bolt. SEE ILLUSTRATION 3.

29. Bolt front spacer tube to the sway bar mount hole in the front axle from the bottom using

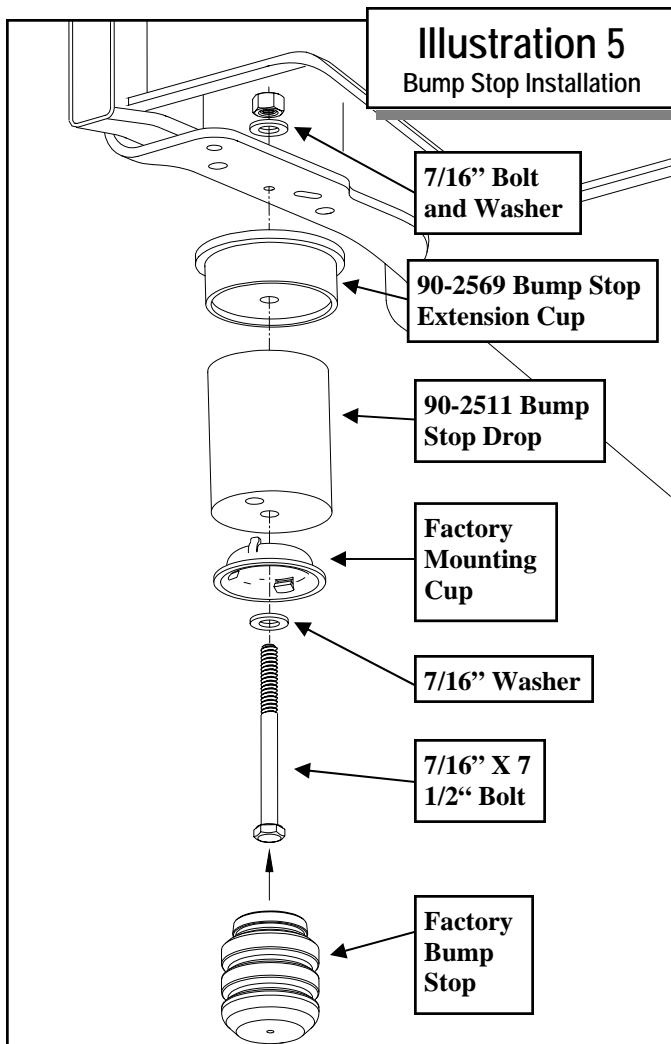

the 9/16" hardware from (90-6400). SEE ILLUSTRATION 4.

30. Install the lower sway bar adapter bracket (90-3251) and one end of the limit strap to the 9/16" X 3 1/2" bolt. Insert the 9/16" X 3 1/2" bolt, with the spacer (90-2521) on the inside of the factory shock pocket, to the factory lower shock mounting hole. Secure using the 9/16" nut plate (90-3267). See ILLUSTRATION 4.

NOTE: Make sure the limit strap (5223-1) is pointing up when installing it on the bolt.

31. Torque the lower mount hardware (center bolt, rear bolt, front bolt) according to the torque chart.
32. Remove the bump stop and unbolt the Pro Comp bump stop extension.
33. Reinstall assembly with the new bump stop extension base cup (90-2569), new 7/16" X 7 1/2" bolt and bump stop. SEE ILLUSTRATION 5.
34. Using the factory isolators reinstall the front coil springs into the spring buckets and raise the axle into place.
35. Thread the 5/8" jam nut about half way down

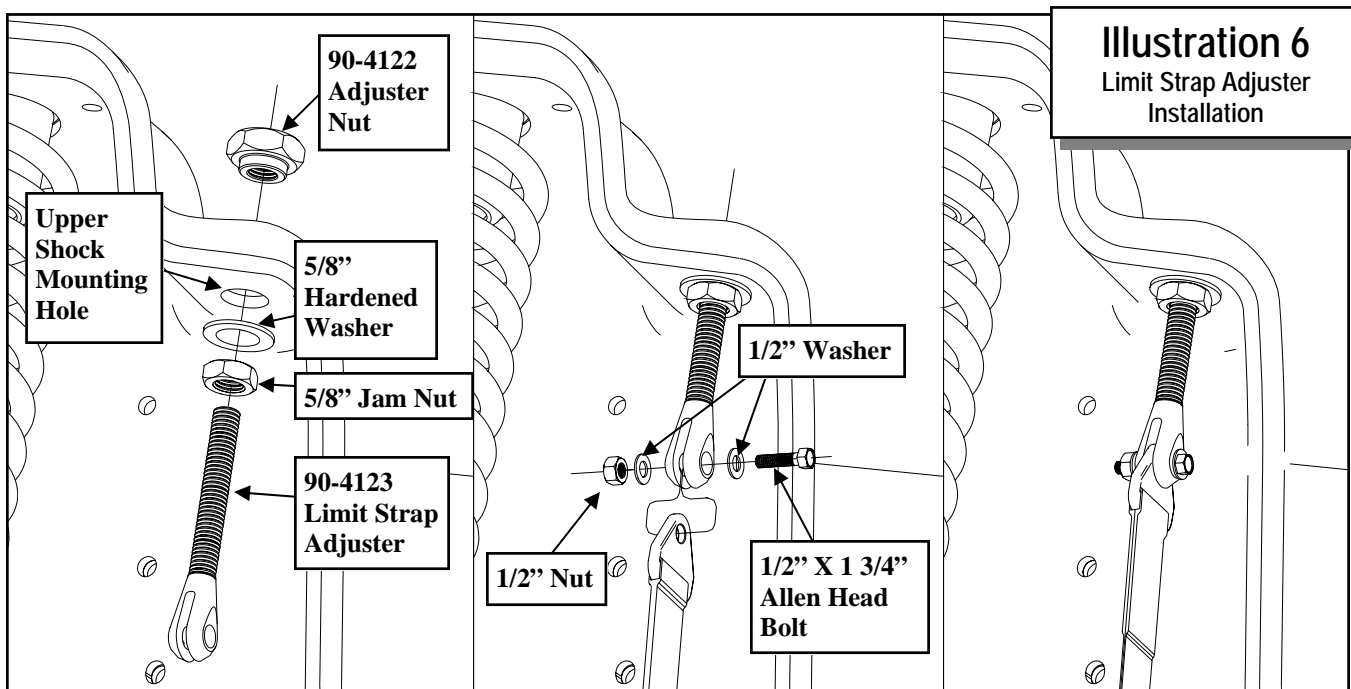

Illustration 6
Limit Strap Adjuster
Installation

the limit strap adjuster (90-4121).

36. From the bottom, insert the limit strap adjuster, 5/8" hardened washer and jam nut into the upper stock shock mount. Secure to the frame using the adjuster nut (90-4123). See ILLUSTRATION 6.

NOTE: Leave strap slightly loose to ease the installation of the upper adjuster to the upper coil bucket.

37. Insert the limit strap top mount into the slit in the limit strap adjuster. Secure using the 1/2"

X 1 3/4" Allen head bolt and hardware. See ILLUSTRATION 6.

38. Install the new shocks (925501 w/ shaft up, MX6129, MX6065R, FX6506 or FX 6303) to the shock hoop using the supplied 1/2" X 2 3/4" bolts. Torque according to the torque chart. Use thread locker on these bolts. See ILLUSTRATION 7.

NOTE: If reusing an existing MX-6 or MX-6R shock use sleeves, bushings and instructions from pack 90-6428.

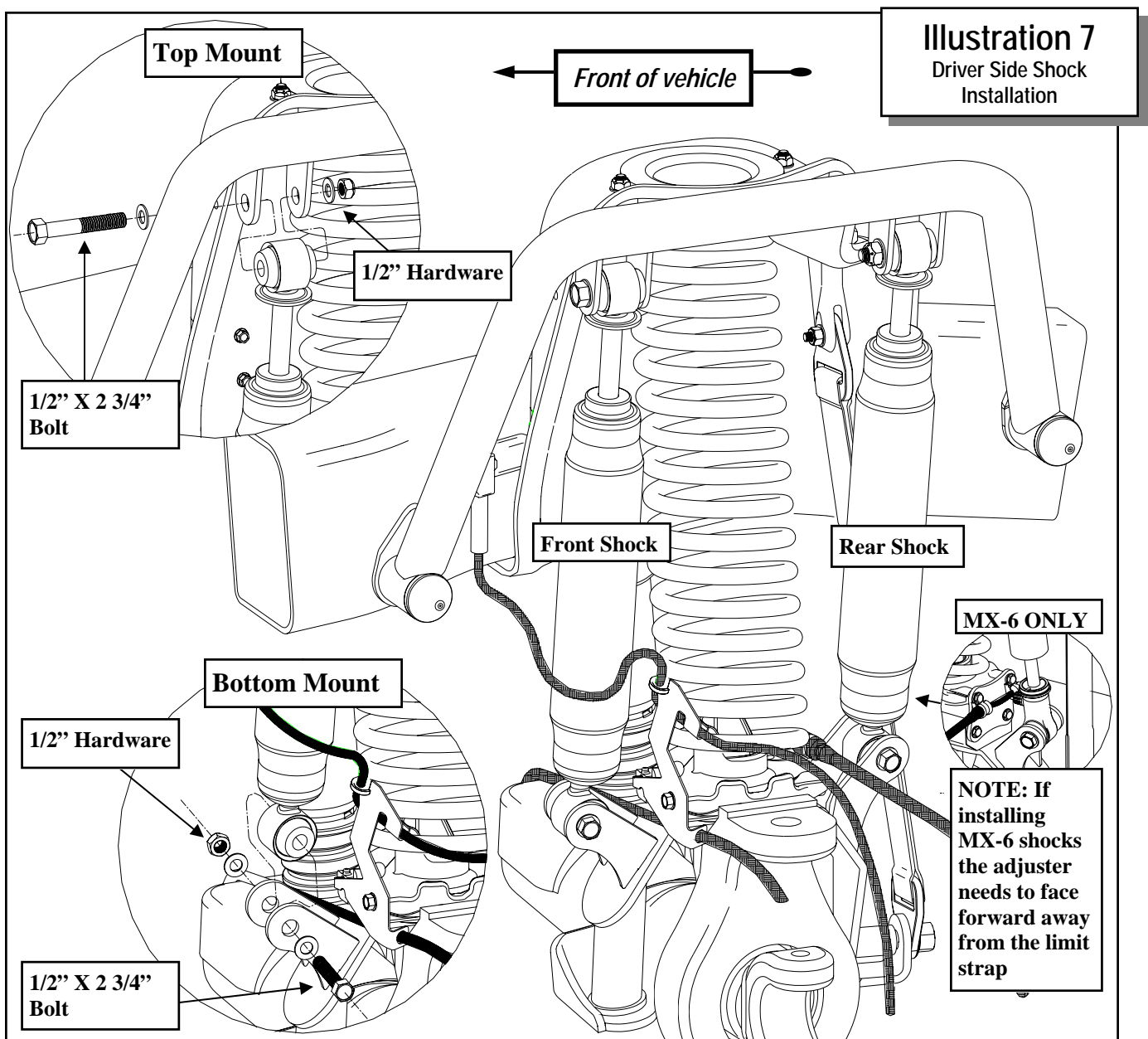

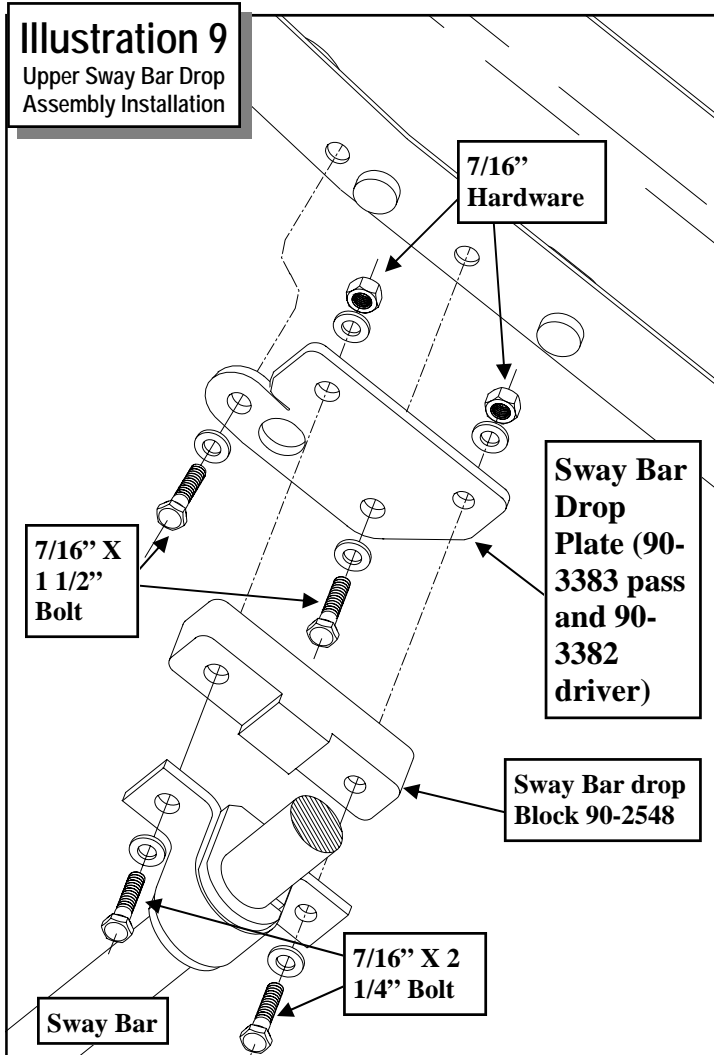
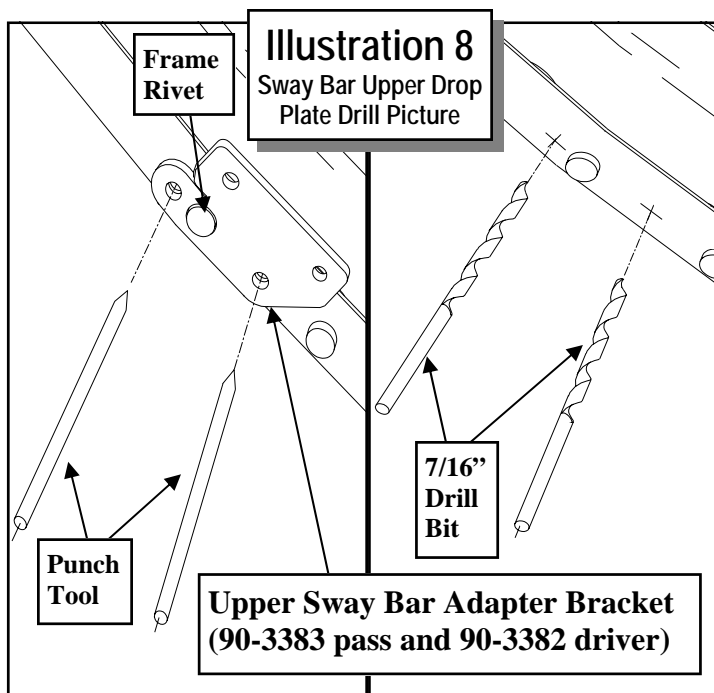

39. Install the bottom of the rear shock to the lower mount using the 1/2" X 2 3/4" bolt and hardware. See ILLUSTRATION 7.

NOTE: If installing the MX-6 or MX-6R shocks the rear shock valve adjuster needs to be facing toward the front of the vehicle to avoid contacting the limit strap.

40. Bolt the previously removed factory brake line bracket and ABS wire clips back onto the coil spacer block side plates using the previously removed hardware.

NOTE: Be sure the brake line is routed in front of the shocks. The upper and lower brake line brackets may need to be bent outward so they will not contact the shocks.

41. Reinstall the front wheel and torque to manufacturer's specifications.

42. At full droop (with wheel installed) adjust the limit strap (5223-1) so that the front shock, at full extension, hangs about 1" below the lower shock mount.

IMPORTANT! Be sure to adjust limit straps so the coil springs are not loose in the upper and lower coil buckets when at full drop.

NOTE: Do to variations in the vehicles from the factory the limit straps may take different amounts of adjustment on the driver side and passenger side.

43. Push the front shock up into the lower front shock mount and secure with the supplied 1/2" X 2 3/4" bolt and hardware. See ILLUSTRATION 7.

44. Repeat on the other side of the vehicle.

45. Mount the upper sway bar drop plate (90-3382 driver) on the driver's side frame rail. Behind the front axle, the bracket will locate on the rear rivet on the frame. SEE ILLUSTRATION 8.

46. Place the drop plate in position on the rear rivet. Using the bracket as a template center punch and drill the (2) 7/16" holes in the frame. SEE ILLUSTRATION 8.

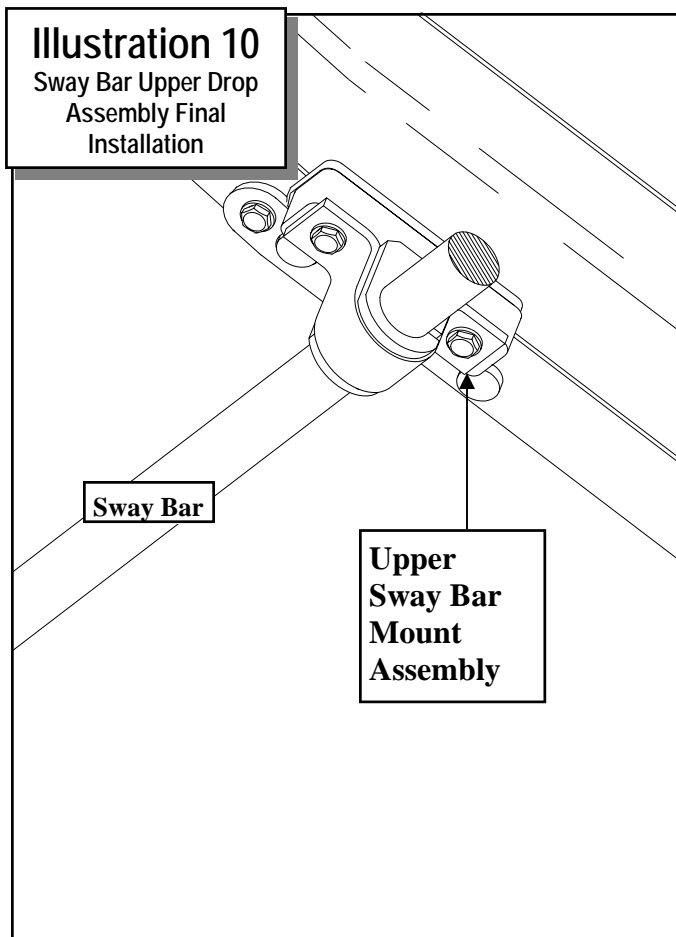

47. Secure the drop plate (90-3382) to the frame using 7/16" X 1 1/2" bolts and hardware. SEE ILLUSTRATION 9.
48. Bolt the sway bar drop block (90-2548) to the previously installed sway bar drop plate (90-3382) using the 7/16" X 2 1/4" bolts and hardware. SEE ILLUSTRATION 9.
49. Repeat on the passenger side using the upper sway bar drop plate (90-3383 passenger) and sway bar drop block (90-2548). SEE ILLUSTRATION 9.
50. Install the sway bar to the upper drop assemblies (90-3383 pass and 90-3382 driver) using the 7/16" X 1 1/4" bolts and hardware. Be sure that the ends of the sway bar are facing toward the front of the vehicle. SEE ILLUSTRATION 9 & 10.

NOTE: You may need to clearance the factory sway bar mount bolt holes to accept the 7/16" Hardware.

51. Assemble the sway bar end links (90-1094) using the bushings and sleeves from hardware pack (90-6413). See ILLUSTRATION 11.

NOTE: Each end link gets (1) 54314 sleeve & (1) bushing 5/8" (600000) on the bottom and (1) 1036 sleeve & (1) bushing 3/4" (600020) on top.

52. Install the assembled sway bar end links (90-1094) to the lower sway bar adapter brackets (90-3251) using the supplied 1/2" X 3" bolt and hardware. See ILLUSTRATION 11.

NOTE: The sway bar end links install with the bend toward the rear of the vehicle.

53. Secure the end links to the sway bar using the 14mm OE bolts with the heads toward to the outside of the truck. See ILLUSTRATION 11.
54. Torque all sway bar hardware according to the torque chart on page 13.
55. Lower the vehicle to the ground and on both sides of the vehicle, check the routing of the brake lines and the ABS wire harnesses.

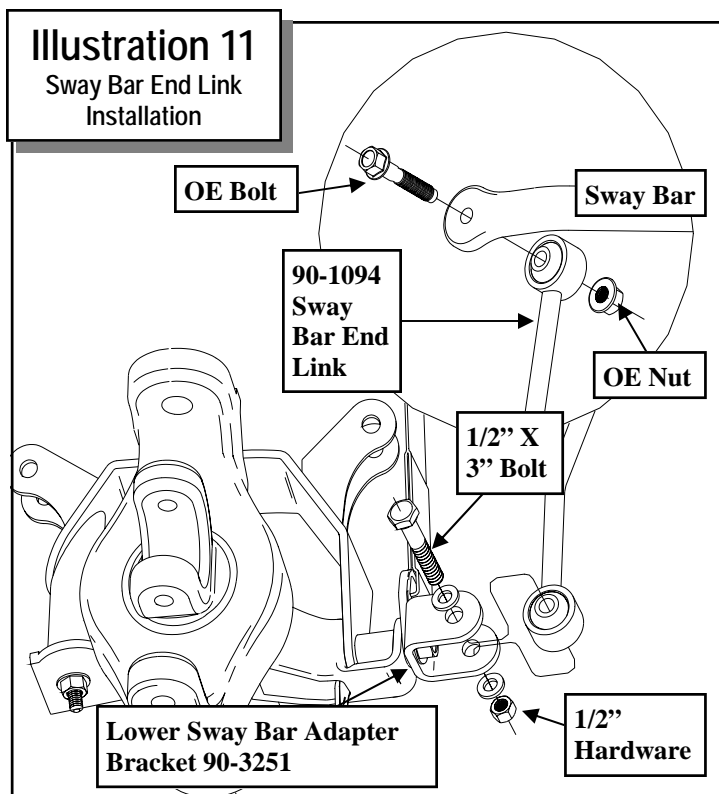

There must be no pinching, rubbing, or stretching of either component. At full droop, cycle the steering from lock to lock while observing the reaction of these components. Reposition them if needed.

56.Re-check the wheel lug torque on all four wheels at this time.

NOTES:

- ⇒ **After 100 miles recheck for proper torque on all newly installed hardware.**
- ⇒ **Recheck all hardware for tightness after off road use.**

Use this only as a guide for hardware without a called out torque specification in the instruction manual.

Bolt Torque and ID						
Decimal System			Metric System			
All Torques in Ft. Lbs. Maximums						
Bolt Size	Grade 5	Grade 8	Bolt Size	Class 9.8	Class 10.9	Class 12.9
5/16	15	20	M6	5	9	12
3/8	30	45	M8	18	23	27
7/16	45	60	M10	32	45	50
1/2	65	90	M12	55	75	90
9/16	95	130	M14	85	120	145
5/8	135	175	M16	130	165	210
3/4	185	280	M18	170	240	290

1/2-13x1.75 HHCS

D T L X

Grade 5 Grade 8
(No. of Marks + 2)

G = Grade (Bolt Strength)
D = Nominal Diameter (Inches)
T = Thread Count (Threads per Inch)
L = Length (Inches)
X = Description (Hex Head Cap Screw)

M 12-1.25x50 HHCS

D T L X

P = Property Class (Bolt Strength)
D = Nominal Diameter (Millimeters)
T = Thread Pitch (Thread Width, mm)
L = Length (Millimeters)
X = Description (Hex Head Cap Screw)

Notice to Owner operator, Dealer and Installer:

Vehicles that have been enhanced for off-road performance often have unique handling characteristics due to the higher center of gravity and larger tires. This vehicle may handle, react and stop differently than many passenger cars or unmodified vehicles, both on and off-road. You must drive your vehicle safely! Extreme care should always be taken to prevent vehicle rollover or loss of control, which can result in serious injury or even death. Always avoid sudden sharp turns or abrupt maneuvers and allow more time and distance for braking! Pro Comp reminds you to fasten your seat belts at all times and reduce speed! We will gladly answer any questions concerning the design, function, maintenance and correct use of our products.

Please make sure your Dealer/Installer explains and delivers all warning notices, warranty forms and instruction sheets included with Pro Comp product.

Application listings in this catalog have been carefully fit checked for each model and year denoted. However, Pro Comp reserves the right to update as necessary, without notice, and will not be held responsible for misprints, changes or variations made by vehicle manufacturers. Please call when in question regarding new model year, vehicles not listed by specific body or chassis styles or vehicles not originally distributed in the USA.

Please note that certain mechanical aspects of any suspension lift product may accelerate ordinary wear of original equipment components. Further, installation of certain Pro Comp products may void the vehicle's factory warranty as it pertains to certain covered parts; it is the consumer's responsibility to check with their local dealer for warranty coverage before installation of the lift.

Warranty and Return policy:

Pro Comp warrants its full line of products to be free from defects in workmanship and materials. Pro Comp's obligation under this warranty is limited to repair or replacement, at Pro Comp's option, of the defective product. Any and all costs of removal, installation, freight or incidental or consequential damages are expressly excluded from this warranty. Pro Comp is not responsible for damages and / or warranty of other vehicle parts related or non-related to the installation of Pro Comp product. A consumer who makes the decision to modify his vehicle with aftermarket components of any kind will assume all risk and responsibility for potential damages incurred as a result of their chosen modifications. Warranty coverage does not include consumer opinions regarding ride comfort, fitment and design. Warranty claims can be made directly with Pro Comp or at any factory authorized Pro Comp dealer.

IMPORTANT! To validate the warranty on this purchase please be sure to mail in the warranty card.

Claims not covered under warranty-

- Parts subject to normal wear, this includes bushings, bump stops, ball joints, tie rod ends and heim joints
 - Discontinued products at Pro Comp's discretion
- Bent or dented product
- Finish after 90 days
- Leaf or coil springs used without proper bump stops
- Light bulbs
- Products with evident damage caused by abrasion or contact with other items
- Damage caused as a result of not following recommendations or requirements called out in the installation manuals
- Products used in applications other than listed in Pro Comp's catalog
- Components or accessories used in conjunction with other manufacturer's systems
- Tire & Wheel Warranty as per Pro Competition Tire Company policy
- Warranty claims without "Proof of Purchase"
- Pro Comp Pro Runner coil over shocks are considered a serviceable shock with a one-year warranty against leakage only. Rebuild service and replacement parts will be available and sold separately by Pro Comp. Contact Pro Comp for specific service charges.
- Pro Comp accepts no responsibility for any altered product, improper installation, lack of or improper maintenance, or improper use of our products.

E-Mail: tech@explorerprocomp.com
Website: www.explorerprocomp.com
Fax: (619) 216-1474
Ph: (619) 216-1444

<u>PLACE</u>
<u>WARRANTY REGISTRATION</u>
<u>NUMBER</u>
HERE: _____