

2360 Boswell Road  
Chula Vista, CA 91914  
Phone 619.216.1444  
Fax 619.216.1474  
E-Mail tech@explorerprocomp.com



## PRO COMP SUSPENSION

---

*Suspension Systems that Work!*

**Part # 55299**  
**1997-2002 Jeep Wrangler - TJ**  
**Rear Track Bar Bracket**

This document contains very important information that includes warranty information and instructions for resolving problems you may encounter. Please keep it in the vehicle as a permanent record.

Part #	Description	Qty.	Illus.	Page
90-1011	TRACK ROD BRACKET	1	1	3
90-2010	SLEEVE	1	1	3
90-6233	<b>HARDWARE PACK</b>	<b>1</b>		
70-0503001500	1/2" X 3" USS GR 5 HEX BOLT	1	1	3
72-05000100512	1/2" USS GR 5 NYLOCK NUT	1	1	3
73-05000030	1/2" SAE FLAT WASHER	2	1	3
70-0371001504	3/8" X 1" USS GR 5 HEX BOLT	1	1	3
72-03700100512	3/8" USS GR 5 NYLOCK NUT	1	1	3
73-03700030	3/8" SAE FLAT WASHER	2	1	3
70-0311001500	5/16" X 1" USS GR 5 HEX BOLT	3	1	3
72-03100100512	5/16" USS GR 5 NYLOCK NUT	3	1	3
73-03100030	5/16" SAE FLAT WASHER	6	1	3

### Before you begin:

- ⇒ Read the instructions and study the illustrations before attempting installation. Separating the parts according to the areas where they will be used and placing the hardware with the brackets before you begin will save installation time.
- ⇒ Check the parts and hardware against the parts list to assure that you kit is complete.
- ⇒ Always wear safety glasses when using power tools.

### Installation Instructions

1. Park your vehicle on a flat, level surface. Block both sides of the front tires. Raise the rear of the vehicle and support it with jack stands forward of the rear trailing arm mounts..  
**WARNING: NEVER WORK UNDER OR AROUND AN UNSUPPORTED VEHICLE!**
2. Remove the track bar bolt at the axle and lower the axle until it hangs free.
3. Use **Illustrations 1, 2, & 3** as a reference and install the rear track bar mount bracket (**PN 90-1011**) using the 1.600" sleeve (**PN 90-2010**) and the supplied hardware. Torque the existing track bar bracket bolt to 74 ft. lbs. Drill out the 3/8" hole at the three 5/16" hole locations using the bracket as a template.
4. Raise the axle and attach the track bar into the new track bar mounting bracket using the hardware provided. Torque this nut to 37 ft. lbs.
5. Check all hardware for proper torque and lower the vehicle to the ground.

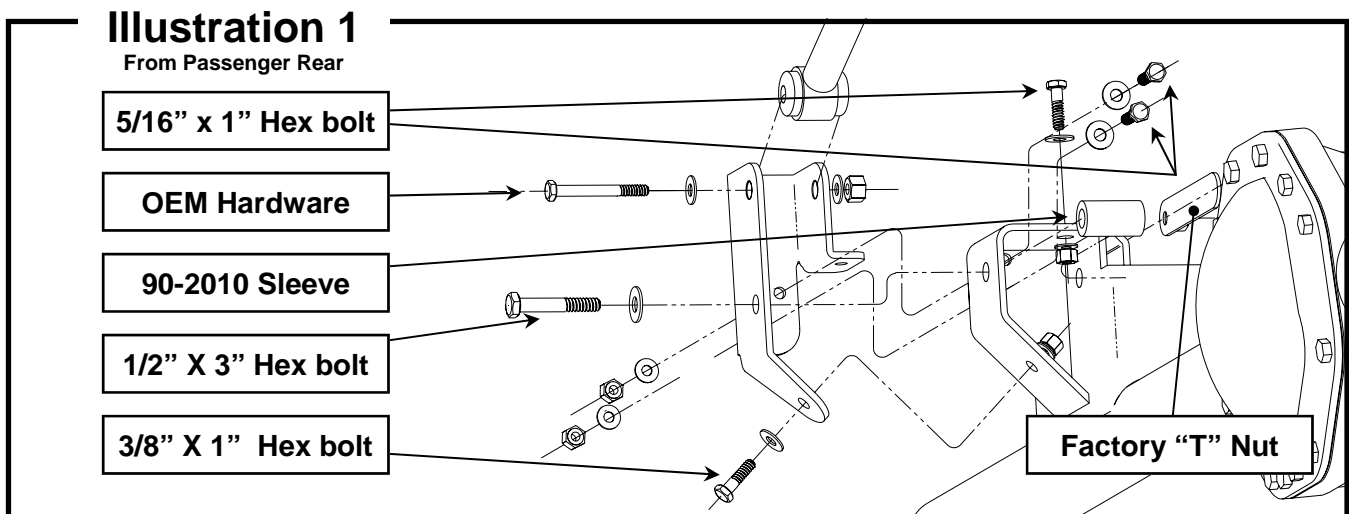

# Illustration 1

From Driver Rear

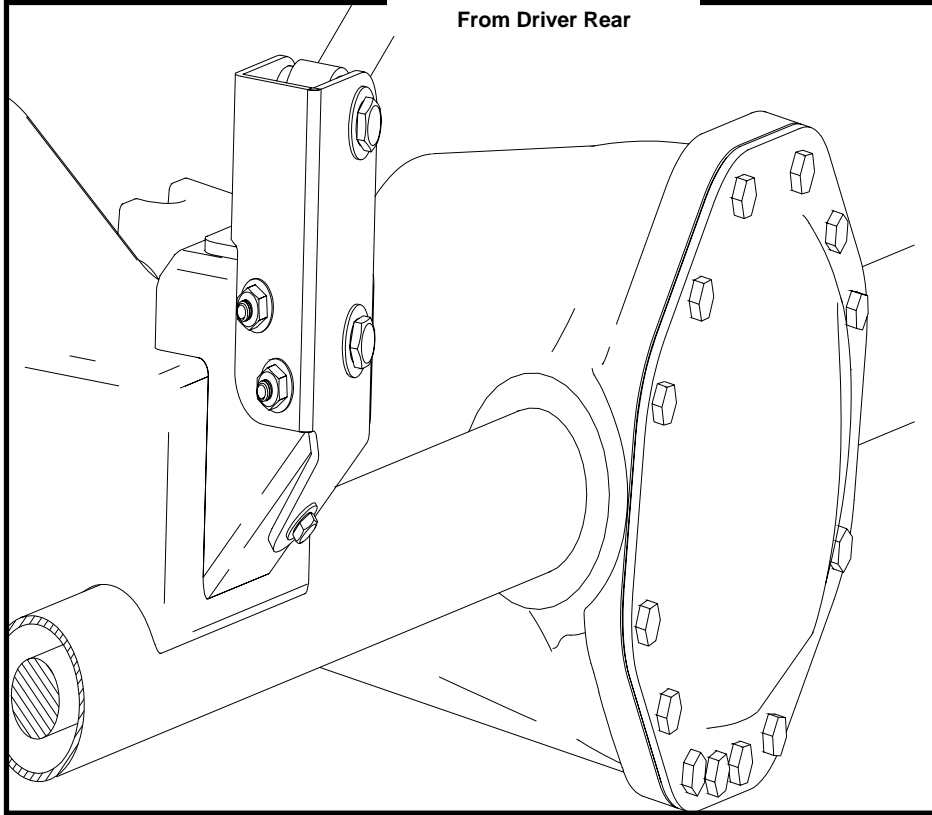

## Completed Views

# Illustration 1

From Passenger Rear

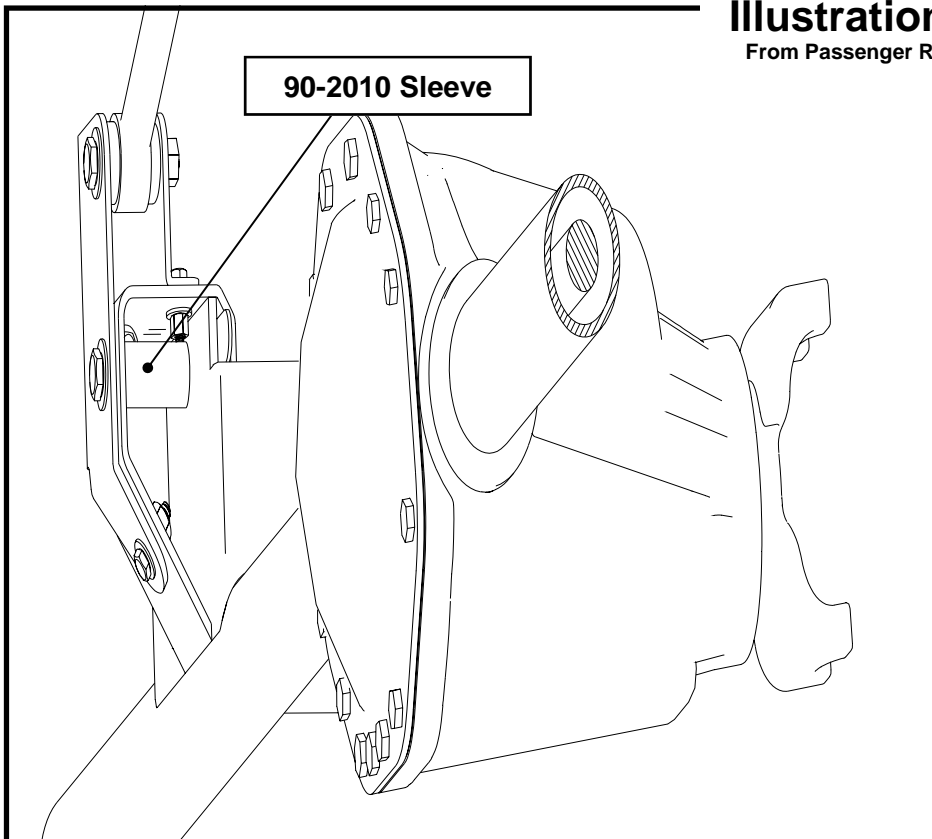

**Notice to Owner operator, Dealer and Installer:**

Vehicles that have been enhanced for off-road performance often have unique handling characteristics due to the higher center of gravity and larger tires. This vehicle may handle, react and stop differently than many passenger cars or unmodified vehicles, both on and off-road. You must drive your vehicle safely! Extreme care should always be taken to prevent vehicle rollover or loss of control, which can result in serious injury or even death. Always avoid sudden sharp turns or abrupt maneuvers and allow more time and distance for braking! Pro Comp reminds you to fasten your seat belts at all times and reduce speed! We will gladly answer any questions concerning the design, function, maintenance and correct use of our products.

**Please make sure your Dealer/Installer explains and delivers all warning notices, warranty forms and instruction sheets included with Pro Comp product.**

Application listings in this catalog have been carefully fit checked for each model and year denoted. However, Pro Comp reserves the right to update as necessary, without notice, and will not be held responsible for misprints, changes or variations made by vehicle manufacturers. Please call when in question regarding new model year, vehicles not listed by specific body or chassis styles or vehicles not originally distributed in the USA.

**Please note that certain mechanical aspects of any suspension lift product may accelerate ordinary wear of original equipment components.** Further, installation of certain Pro Comp products may void the vehicle's factory warranty as it pertains to certain covered parts; it is the consumer's responsibility to check with their local dealer for warranty coverage before installation of the lift.

**Warranty and Return policy:**

Pro Comp warrants its full line of products to be free from defects in workmanship and materials. Pro Comp's obligation under this warranty is limited to repair or replacement, at Pro Comp's option, of the defective product. Any and all costs of removal, installation, freight or incidental or consequential damages are expressly excluded from this warranty. Pro Comp is not responsible for damages and / or warranty of other vehicle parts related or non-related to the installation of Pro Comp product. A consumer who makes the decision to modify his vehicle with aftermarket components of any kind will assume all risk and responsibility for potential damages incurred as a result of their chosen modifications. Warranty coverage does not include consumer opinions regarding ride comfort, fitment and design. Warranty claims can be made directly with Pro Comp or at any factory authorized Pro Comp dealer.

**IMPORTANT!** To validate the warranty on this purchase please be sure to mail in the warranty card.

**Claims not covered under warranty-**

- Parts subject to normal wear, this includes bushings, bump stops, ball joints, tie rod ends and heim joints
  - Discontinued products at Pro Comp's discretion
- Bent or dented product
- Finish after 90 days
- Leaf or coil springs used without proper bump stops
- Light bulbs
- Products with evident damage caused by abrasion or contact with other items
- Damage caused as a result of not following recommendations or requirements called out in the installation manuals
- Products used in applications other than listed in Pro Comp's catalog
- Components or accessories used in conjunction with other manufacturer's systems
- Tire & Wheel Warranty as per Pro Competition Tire Company policy
- Warranty claims without "Proof of Purchase"
- Pro Comp Pro Runner coil over shocks are considered a serviceable shock with a one-year warranty against leakage only. Rebuild service and replacement parts will be available and sold separately by Pro Comp. Contact Pro Comp for specific service charges.
- Pro Comp accepts no responsibility for any altered product, improper installation, lack of or improper maintenance, or improper use of our products.

E-Mail: [tech@explorerprocomp.com](mailto:tech@explorerprocomp.com)  
Website: [www.explorerprocomp.com](http://www.explorerprocomp.com)  
Fax: (619) 216-1474  
Ph: (619) 216-1444

<b>PLACE</b>
<b>WARRANTY REGISTRATION</b>
<b>NUMBER</b>
<b>HERE:</b> _____