

2360 Boswell Road  
Chula Vista, CA 91914  
Phone 619.216.1444  
Fax 619.216.1474  
E-Mail tech@explorerprocomp.com



## PRO COMP SUSPENSION

---

Suspension Systems that Work!

**PLEASE NOTE:** This kit is designed to be used in conjunction with a Pro Comp Suspension lift kit. While this kit may work with other suspension kits, we cannot guarantee fit or performance unless used with genuine Pro Comp Suspension equipment!

This document contains important information that includes warranty information and instructions for resolving problems you may encounter. Please keep it in the vehicle as a permanent record.

**P/N 75006  
REAR TRACTION BAR  
KIT  
2006 DODGE 1500  
(To be used with lift block ONLY)**

This document contains very important information that includes warranty information and instructions for resolving problems you may encounter. Please keep it in the vehicle as a permanent record.

**PART LIST**

Part #	Description	Qty	Illus.	Page
<b>90-3637</b>	<b>TRACK BAR AXLE MOUNT</b>	<b>2</b>	<b>1</b>	<b>3</b>
<b>90-1618</b>	<b>TRACK BAR FRAME MOUNT</b>	<b>2</b>	<b>3,4,5</b>	<b>4,5</b>
<b>90-6163</b>	<b>HARWARE PACK: Bushings and Sleeves</b>	<b>1</b>	<b>-</b>	<b>-</b>
90-2192	SLEEVE: 7/8" X 9/16" X 2.812"	2	2,3	4
90-2193	SLEEVE: 7/8" X 9/16" X 3.937"	2	2	4
15-10953	BUSHING	8	2,3	4
<b>90-6162</b>	<b>HARWARE PACK: Front and Rear Mounts</b>	<b>1</b>	<b>-</b>	<b>-</b>
70-0565501800	9/16" X 5 1/2" USS Hex Bolt	2	1,3,5	3,4,5
70-0564501800	9/16" X 4 1/2" USS Hex Bolt	2	1,3,5	3,4,5
70-05600100816	9/16" USS Nylock Nut	4	1,3,5	3,4,5
70-05600034	9/16" SAE Washer	8	1,3,5	3,4,5
<b>90-6499</b>	<b>HARWARE PACK: Front Mounts to Frame</b>	<b>1</b>	<b>-</b>	<b>-</b>
70-0434251800	7/16" X 4 1/4" USS Hex Bolt	4	5	5
70-04300100816	7/16" USS Nylock Nut	4	5	5
70-04300034	7/16" SAE Flat Washer	8	5	5
<b>Additional Parts Needed: (Sold Separately)</b>				
<b>72500</b>	<b>TRACTION BARS:</b>	<b>-</b>	<b>-</b>	<b>-</b>
<b>90-2350</b>	<b>LATERAL TRACK BAR- Drvr</b>	<b>1</b>	<b>1,2,3,4,5</b>	<b>3,4,5</b>
<b>90-2353</b>	<b>LATERAL TRACK BAR- Pass</b>	<b>1</b>	<b>1,2,3,4,5</b>	<b>3,4,5</b>

- ◆ This installation requires a professional mechanic!
- ◆ Prior to installation, carefully inspect the vehicle's steering and driveline systems paying close attention to the tie rod ends, ball joints, wheel bearing preload, pitman and idler arm. Additionally, check steering-to-frame and suspension-to-frame attaching points for stress cracks. The overall vehicle must be in excellent working condition. Repair or replace all worn or damaged parts!
- ◆ Read the instructions carefully and study the illustrations before attempting installation! You may save yourself a lot of extra work.
- ◆ Check the parts and hardware against the parts list to assure that your kit is complete. Separating parts according to the areas where they will be used and placing the hardware with the brackets before you begin will save installation time.
- ◆ Check the special equipment list and ensure the availability of these tools.
- ◆ Secure and properly block the vehicle prior to beginning installation.
- ◆ **ALWAYS** wear safety glasses when using power tools or working under the vehicle!
- ◆ Use caution when cutting is required under the vehicle. The factory undercoating is flammable. Take appropriate precautions. Have a fire extinguisher close at hand.
- ◆ Foot pound torque readings are listed on the Torque Specifications chart at the end of the instructions. These are to be used unless specifically directed otherwise. Apply Loctite retaining compound where specified.

## INSTALLATION INSTRUCTIONS

1. Place floor jack under rear axle and raise vehicle. Place jack stands under frame to support vehicle. Set emergency brake and block front wheels, in front and behind tires.
2. Working on one side of the vehicle at a time, raise the rear tire off the ground, place a jack stand on the flat part of the frame ahead of the rear wheels and remove the wheel.
3. Support the axle with your floor jack and remove the U-bolts from the axle.
4. Carefully lower the axle away from the spring pack until there is sufficient clearance to insert the track bar rear mount (90-3637) between the spacer block and the axle mount pad as shown in ILLUSTRATION 1. Do not overextend brake lines or axle vent hose. Both may need rerouting or replacement!
5. Raise the axle back up into position. Make sure to carefully line up the locating bolts and dowels to insure

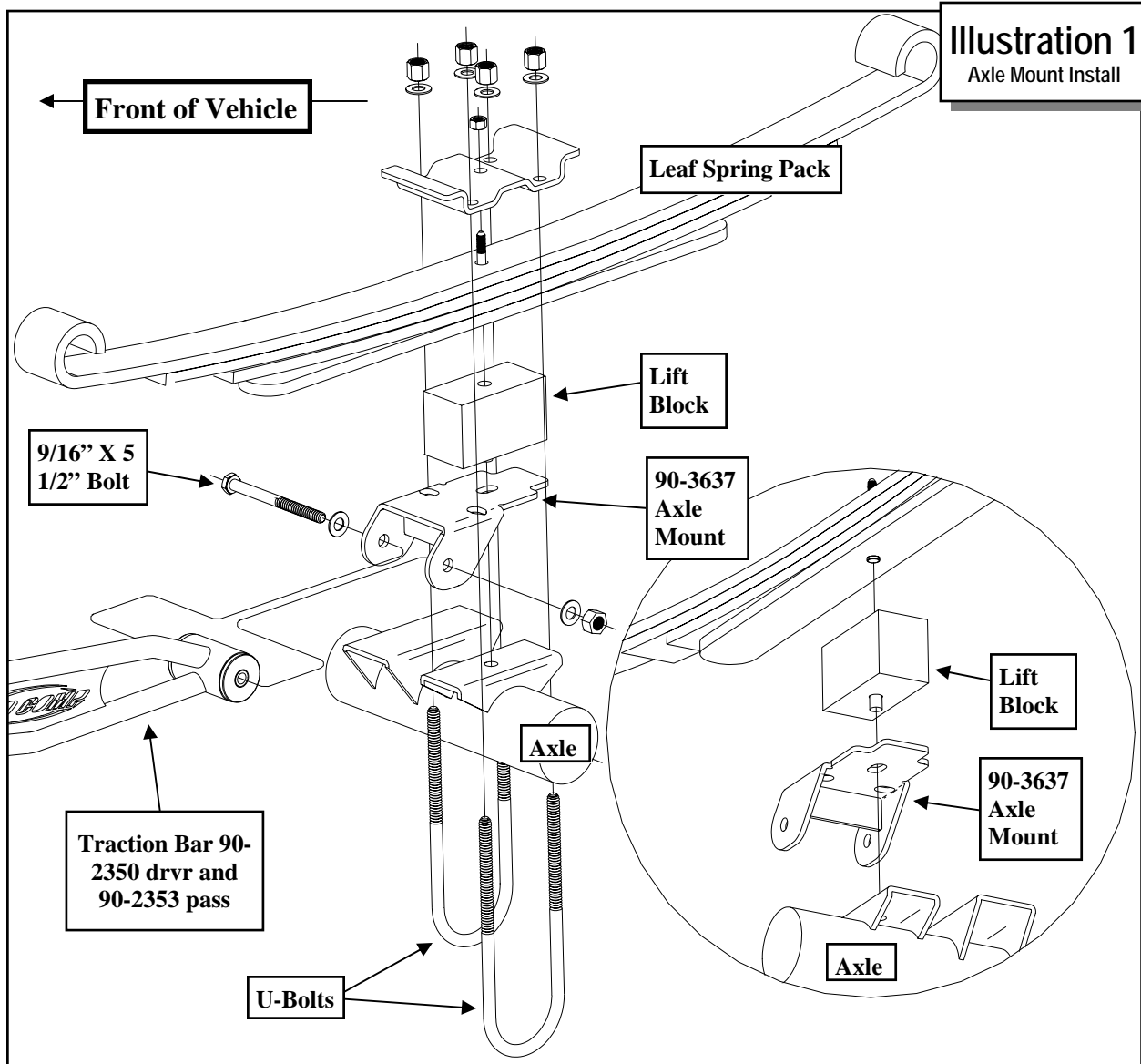

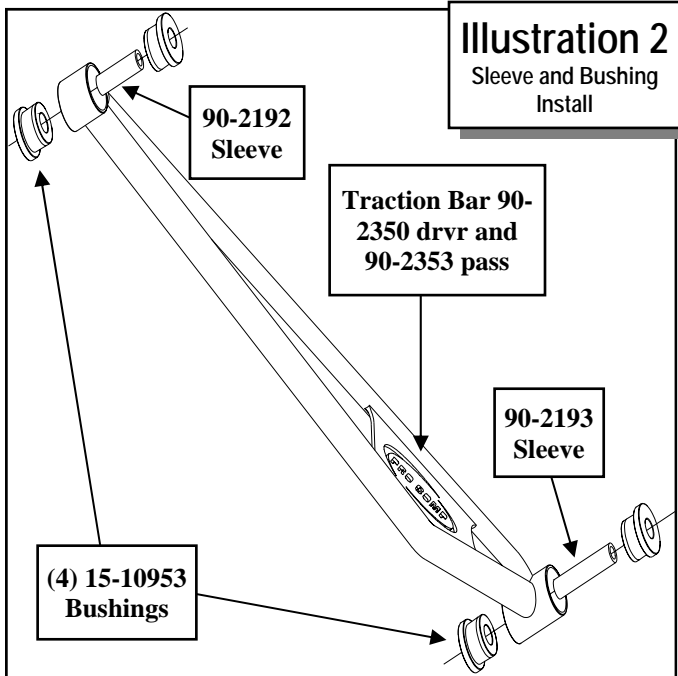

proper alignment. Reinstall the U-bolts, nuts, and washers and torque to **100** ft. lbs. See ILLUSTRATION 1.

6. Install the urethane bushings (**15-10953**) and sleeves (**90-2192 front** and **90-2193 rear**) into your traction bars (*Bars sold separately*) using ILLUSTRATION 2 for reference.
7. Using the **9/16" X 5 1/2"** bolts install lateral traction bars (**90-2353 Pass** and **90-2350 Drvr**) into the rear mounts. See ILLUSTRATION 1.
8. Install the front mounts (**90-1618**) to the traction bars with the **9/16" X 4 1/2"** bolts provided. Leave loose for the moment. See ILLUSTRATION 3.
9. Repeat on the remaining side of the vehicle.
10. Install the tire back on the vehicle and lower the vehicle to the ground.

**NOTE: It is VERY important that the next step is done with the truck on the ground, and the suspension is at normal ride height.**

11. Raise the track bar up until the front mount (**90-1618**) is in full contact with the frame. Mark the location of the holes in the front mount on the frame (inner and outer) and lower the traction bar. Center punch the locations of the mount holes and drill the (2) holes out with a **29/64"** drill bit. See ILLUSTRATION 4.
12. Remove the front mount from the traction bar. Bolt the front mount to the frame using the (2) supplied **7/16" X 4 1/4"** bolts and hardware. See ILLUSTRATION 5.
13. Reinstall the front mounts (**90-1618**) to the traction bars with the previously removed **9/16" X 4 1/2"**. See ILLUSTRATION 5.
14. Repeat steps **11** and **13** on the remaining side of the vehicle to finish the installation.
15. Torque all fasteners according to the specifications on page **5**.

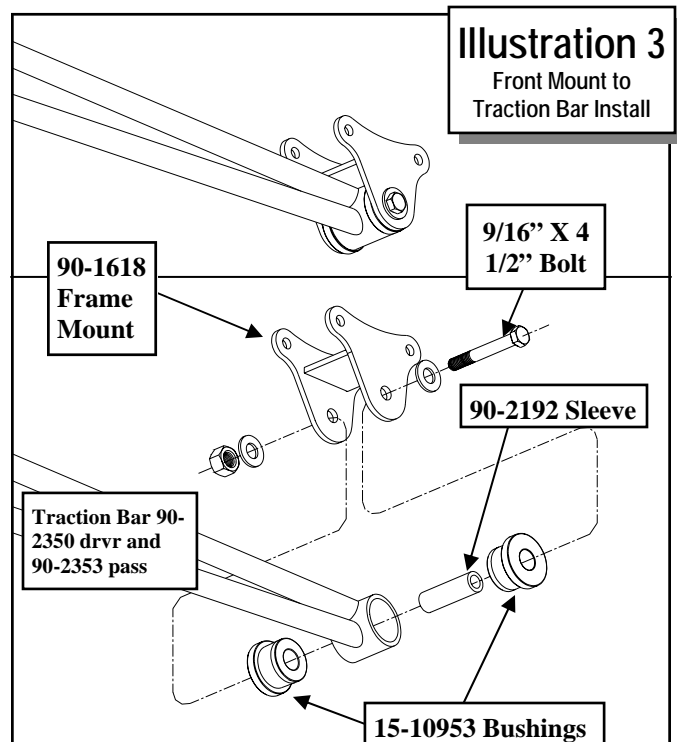

**NOTES:**

- ⇒ After 100 miles recheck for proper torque on all newly installed hardware.
- ⇒ Recheck all hardware for tightness after off road use.

Torque Specifications: Grade 8 hardware only		
7/16"	Bolts.....	35 ft./lbs.
9/16"	Bolts.....	105 ft./lbs

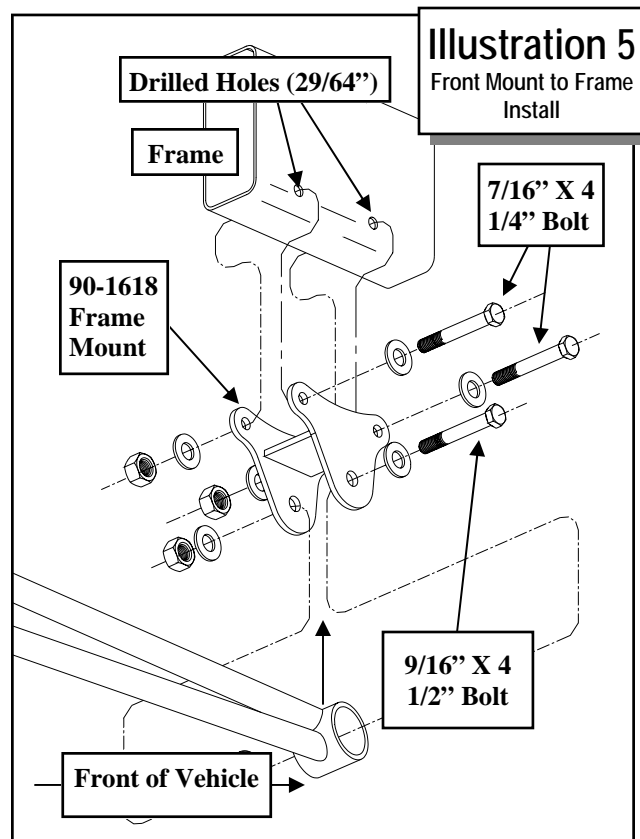
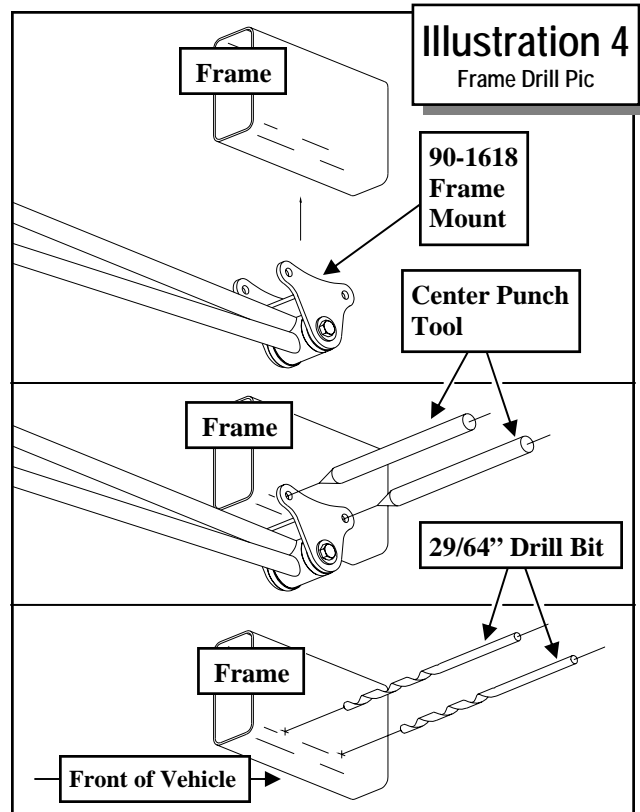

**Notice to Owner operator, Dealer and Installer:**

Vehicles that have been enhanced for off-road performance often have unique handling characteristics due to the higher center of gravity and larger tires. This vehicle may handle, react and stop differently than many passenger cars or unmodified vehicles, both on and off-road. You must drive your vehicle safely! Extreme care should always be taken to prevent vehicle rollover or loss of control, which can result in serious injury or even death. Always avoid sudden sharp turns or abrupt maneuvers and allow more time and distance for braking! Pro Comp reminds you to fasten your seat belts at all times and reduce speed! We will gladly answer any questions concerning the design, function, maintenance and correct use of our products.

**Please make sure your Dealer/Installer explains and delivers all warning notices, warranty forms and instruction sheets included with Pro Comp product.**

Application listings in this catalog have been carefully fit checked for each model and year denoted. However, Pro Comp reserves the right to update as necessary, without notice, and will not be held responsible for misprints, changes or variations made by vehicle manufacturers. Please call when in question regarding new model year, vehicles not listed by specific body or chassis styles or vehicles not originally distributed in the USA.

**Please note that certain mechanical aspects of any suspension lift product may accelerate ordinary wear of original equipment components.** Further, installation of certain Pro Comp products may void the vehicle's factory warranty as it pertains to certain covered parts; it is the consumer's responsibility to check with their local dealer for warranty coverage before installation of the lift.

**Warranty and Return policy:**

Pro Comp warrants its full line of products to be free from defects in workmanship and materials. Pro Comp's obligation under this warranty is limited to repair or replacement, at Pro Comp's option, of the defective product. Any and all costs of removal, installation, freight or incidental or consequential damages are expressly excluded from this warranty. Pro Comp is not responsible for damages and / or warranty of other vehicle parts related or non-related to the installation of Pro Comp product. A consumer who makes the decision to modify his vehicle with aftermarket components of any kind will assume all risk and responsibility for potential damages incurred as a result of their chosen modifications. Warranty coverage does not include consumer opinions regarding ride comfort, fitment and design. Warranty claims can be made directly with Pro Comp or at any factory authorized Pro Comp dealer.

**IMPORTANT!** To validate the warranty on this purchase please be sure to mail in the warranty card.

**Claims not covered under warranty-**

- Parts subject to normal wear, this includes bushings, bump stops, ball joints, tie rod ends and heim joints
  - Discontinued products at Pro Comp's discretion
- Bent or dented product
- Finish after 90 days
- Leaf or coil springs used without proper bump stops
- Light bulbs
- Products with evident damage caused by abrasion or contact with other items
- Damage caused as a result of not following recommendations or requirements called out in the installation manuals
- Products used in applications other than listed in Pro Comp's catalog
- Components or accessories used in conjunction with other manufacturer's systems
- Tire & Wheel Warranty as per Pro Competition Tire Company policy
- Warranty claims without "Proof of Purchase"
- Pro Comp Pro Runner coil over shocks are considered a serviceable shock with a one-year warranty against leakage only. Rebuild service and replacement parts will be available and sold separately by Pro Comp. Contact Pro Comp for specific service charges.
- Pro Comp accepts no responsibility for any altered product, improper installation, lack of or improper maintenance, or improper use of our products.

E-Mail: [tech@explorerprocomp.com](mailto:tech@explorerprocomp.com)  
Website: [www.explorerprocomp.com](http://www.explorerprocomp.com)  
Fax: (619) 216-1474  
Ph: (619) 216-1444

<b>PLACE</b> <b>WARRANTY REGISTRATION</b> <b>NUMBER</b> <b>HERE:</b> _____
-------------------------------------------------------------------------------------