

2360 Boswell Road
Chula Vista, CA 91914
Phone 619.216.1444
Fax 619.216.1474
E-Mail tech@explorerprocomp.com



PRO COMP SUSPENSION

Suspension Systems that Work!

**Part # 51893 / 51894
Chevy/GMC 4WD 3/4 1
Ton
(8-Lug) IFS 1988 - 1999
6 inch Lift**

***DO NOT INSTALL ON VEHICLES EQUIPPED WITH AUTO TRAC 246
TRANSFER CASE.***

This document contains very important information that includes warranty information and instructions for resolving problems you may encounter. Please keep it in the vehicle as a permanent record.

Box 1 of 4 PN 51893/51894-1

PART#	DESCRIPTION	QUANTITY	ILLUSTRATION#
90-1146	Lower A-Arm Front Drop Bracket	2	13
90-1151	Lower A-Arm Rear Drop Bracket	2	11
90-3012	Front Diff. Drop Bracket (Drvr.)	1	9
90-1355	Front Diff. Drop Bracket (Pass.)	1	10
90-6064	Hardware Pack Containing:	-	-
90-2097	Sway Bar Extension	2	16A
90-6065	Hardware Pack Containing:	-	-
90-1010	Brkt, Sway Bar Front Mount	2	16A
117300007	Washer, Retainer	4	16A
45359	Hourglass Bushing, Black	2	16A
61150	Sleeve, 5/8" x 1.48" Lg.	2	16A
90-2039	Sleeve, 5/8" x .25 Lg.	2	16A
8337-1	3/8" SAE Hex Nut	2	16A
90-6024	Hardware Pack Containing: Sway bar	-	-
70-0371501500	3/8" x 1 1/2" USS Gd. 5	2	16A
70-0372501500	3/8" x 2 1/2" Gd. 5 Hex Bolt	2	16A
72-03700100512	3/8" USS Gd. 5 Nyloc Nut	4	16A
73-03700030	3/8" SAE Flat Washer	4	16A
73-03700042	3/8" USS Hardened Flat Washer	2	16A
90-6076	Hardware Pack Containing: Crossmember	-	-
70-0501501500	1/2" x 1 1/2" USS Gd. 5 Hex Bolt	2	13
70-0621501501	5/8" x 1 1/2" USS Gd. 5 Hex Bolt	4	11
70-0624501500	5/8" x 4 1/2" USS Gd. 5 Hex Bolt	2	13
70-0625501500	5/8" x 5 1/2" USS Gd. 5 Hex Bolt	4	11,13
70-0625001500	5/8" x 5" USS Gd. 5 Hex Bolt	2	13
72-05000100512	1/2" USS Nyloc Nut	2	13
72-06200100512	5/8" USS Nyloc Nut	12	11,13
73-05000030	1/2" SAE Flat Washer	4	13
73-06200030	5/8" SAE Flat Washer	24	11,13
73-06200032	5/8" USS Flat Washer	4	11
90-6085	Hardware Pack Containing: Bushing	-	-
600040-1	Cut 5/8" Black "T" Bushing	4	
45558	Straight 5/8" Black Bushing	4	
90-6147	Hardware Pack Containing: Center link/Diff	-	-
70-0621501500	5/8" x 1 1/2" USS Gd. 5 Hex Bolt	2	10
70-0564001500	9/16" x 4" USS Gd. 5 Hex Bolt	1	9
70-0503001500	1/2" x 3" USS Gd. 5 Hex Bolt	1	10
70-0503751500	1/2" x 3 3/4" USS Gd. 5 Hex Bolt	1	8
72-06200100512	5/8" USS Nyloc Nut	2	10
72-05600100512	9/16" USS Nyloc Nut	1	9
72-05000100512	1/2" USS Nyloc Nut	2	8,10
73-06200030	5/8" SAE Flat Washer	4	10
73-05600030	9/16" SAE Flat Washer	2	9
73-05000030	1/2" SAE Flat Washer	4	8,10

PART#	DESCRIPTION	QUANTITY	ILLUSTRATION#
	Loctite Tube - Small Red	2	-
90-6148	Hardware Pack Containing:	-	-
15-11018	Bumpstop - Low Profile	2	13
15-11031	Cone Bump stop	2	11
15-11304	Bushing - Pivot Sleeve	2	7,8
15-11148	Bushing - Differential Mount	8	14
90-2085	Pivot Sleeve	2	7,8
90-2109	Sleeve - 2-3/4" Compression Strut	4	14
90-2110	Sleeve - GM Compression Strut	2	14
72-03700100512	3/8" USS Gd. 5 Nyloc Nut	4	11,13
Box 2 of 4 PN 51893/51894-2			
13-90347	U-Bolt - Square 5/8" - 2-5/8"	4	18
20-65471	5/8" U-Bolt Hardware Pack	1	18
90-1882	Upper A-Arm Drop Passenger	1	12
90-1877	Upper A-Arm Drop Driver	1	12
90-4011	Torsion Bar Drop	2	17
90-6078	Hardware Pack Containing: A arm drop	-	-
70-0505501500	1/2" x 5 1/2" USS Gd. 5 Hex Bolt	6	12
72-05000100512	1/2" USS Nyloc Nut	6	12
73-05000030	1/2" SAE Flat Washer	12	12
90-6080	Hardware Pack Containing: Torsion bars	-	-
70-0375001500	3/8" x 5" USS Gd. 5 Hex Bolt	2	17
70-0504001500	1/2" x 4" USS Gd. 5 Hex Bolt	4	17
72-05000100512	1/2" USS Nyloc Nut	4	17
72-03700100512	3/8" USS Nyloc Nut	2	17
73-03700030	3/8" SAE Flat Washer	4	17
73-05000030	1/2" SAE Flat Washer	8	17
90-6170	Cam Bolt Hardware Pack Containing:	-	-
42-778T	Cam Bolt Assembly	4	12
90-6083	Hardware Pack Containing:A arm drop	-	-
90-2111	Sleeve w/ Washer	2	12
90-2112	Sleeve - .750" x .50" x 3.94"	2	12
90-2113	Sleeve - .750" x .50" x 3.44"	2	12
90-1215	Load Washer, Flat Side 2.0" O.D. x .550" I.D.	6	12
90-1216	Load / Washer - 1.50" O.D. x .532" I.D.	2	13
95-400	4" Lift Block	2	18
96-1313	Differential Mount Cover Plate	1	3
Box 3 of 4 PN 51893/51894-3			
90-1104	Compression Strut Mount	2	14
90-1133	Steering Link Support Arm / Deep	1	7
90-1163	Front Upper Crossmember	1	13
90-1164	Front Lower Crossmember	1	13
90-1768	Center Steering Link	1	8
90-1171	Steering Link Support Arm/Shallow	1	7
90-1173	3 Bolt Idler Arm Spacer	1	5,6

PART#	DESCRIPTION	QUANTITY	ILLUSTRATION#
90-1366	Rear Lower Crossmember	1	11
90-2074	Lateral Compression Strut	2	14
90-6075	Hardware Pack Containing: Center link/ Idler arm	-	-
70-0502251500	1/2" x 2 1/4" USS Gd. 5 Hex Bolt	1	7
70-0503001500	1/2" x 3" USS Gd. 5 Hex Bolt	3	5,6
70-0503251500	1/2" x 3 1/4" USS Gd. 5 Hex Bolt	1	8
73-05000030	1/2" SAE Flat Washer	10	5,6,7,8
72-05000100512	1/2" USS Nyloc Nut	2	5,6,7,8
90-6079	Hardware Pack Containing: Struts	-	-
70-0503001500	1/2" x 3" USS Gd. 5 Hex Bolt	2	14
70-0504001500	1/2" x 4" USS Gd. 5 Hex Bolt	4	14
72-05000100512	1/2" USS Nyloc Nut	6	14
73-05000030	1/2" SAE Flat Washer	12	14
Box 4 of 4 PN 51893-4			
324501	Front Shocks	2	-
329500	Rear Shocks	2	-
219200	Steering Stabilizer	1	10
OR Box 4 of 4 PN 51894-4			
322501	Front Shocks	2	17A
329500	Rear Shocks	2	-
219200	Steering Stabilizer	1	10
5213-1	Limit Straps	2	17A

88-92 Vehicles require 2 to 3 bolt idler arm conversion upgrade part # 51090 and factory GM 3 bolt idler arm part #12540218 or 2 bolt idler arm spacer part # 90-6102. PLEASE NOTE: All parts sold separately.

NOTICE TO INSTALLER AND OPERATOR:

On '94-'95 vehicles equipped with new down-sized spicer type u-joint front driveshafts and operated in 4WD on even surfaces such as pavement. Front end noise and vibration may occur. It is recommended not to exceed 20mph in these conditions or replacement to a C.V. style (early model) front driveshaft may be required.

Optional Equipment Available from your Pro Comp Distributor!

**The following part is used in conjunction with this kit and, must be ordered separately.

skid plates, traction bars, light bars and multiple shock kits.

Also, check out our outstanding selection of Pro Comp tires to compliment your new installation!

Introduction:

- ◆ This installation requires a professional mechanic!
- ◆ We recommend that you have access to a factory service manual for your vehicle to assist in the disassembly and reassembly of your vehicle. It contains a wealth of detailed information.
- ◆ Prior to installation, carefully inspect the vehicle's steering and driveline systems paying close attention to the tie rod ends, ball joints, wheel bearing preload, pitman and idler arm. Additionally, check steering-to-frame and suspension-to-frame attaching points for stress cracks. The overall vehicle must be in excellent working condition. Repair or replace all worn or damaged parts!
- ◆ Read the instructions carefully and study the illustrations before attempting installation! The more familiar you are with the procedures, the easier and quicker your installation will be.
- ◆ Check the parts and hardware against the parts list to assure that your kit is complete. Separating parts according to the areas where they will be used and placing the hardware with the brackets before you begin will save installation time.
- ◆ Secure and properly block vehicle prior to beginning installation.
- ◆ **ALWAYS** wear safety glasses when using power tools or working under the vehicle!
- ◆ Use caution when cutting is required under the vehicle. The factory undercoating is flammable. Take appropriate precautions. Have a fire extinguisher close at hand.
- ◆ Foot pound torque readings are listed on the Torque Specifications chart at the end of the instructions. These are to be used unless specifically directed otherwise.

Please Note:

- ◆ Front end realignment will be necessary.
- ◆ Speedometer and ABS recalibration are necessary if larger tires (10% more than stock diameter) are installed.
- ◆ This system utilizes the stock torsion bars which normally afford the best ride quality. If, after the kit is installed, ride or handling seems too "soft", heavier Gross Vehicle Weight Rating (GVWR) bars can be installed. GM offers various bars up to 10,500 lbs. GVWR.
- ◆ Tire and wheel choice is crucial in assuring proper fit, performance, and the safety of your Pro Comp equipped vehicle. For this application, a wheel not to exceed 9" in width with a minimum backspacing of 4" must be used. Additionally, a quality tire of radial design, not exceeding 35" tall X 12.5" wide is recommended. Please note that the use of a 35" X 12.5" tire may require fender modification. Violation of these recommendations will not be endorsed as acceptable by Pro Comp Suspension and will void any and all warranties either written or implied.
- ◆ **Purchase of a new PRO COMP drive shaft may be necessary to eliminate driveline vibration.**
- **WARNING: Be extremely careful when loading or unloading the torsion bars! There is a**

tremendous amount of stored energy in the bars. Keep your hands and body clear of the adjuster arm assembly and puller tool in case anything slips or breaks! Remember your safety glasses!

- While we have listed the hardware that is to be kept and that to be discarded, it would be wise to keep all hardware until the installation is complete.
- Exhaust may need modification after lift kit has been installed to clear front driveline. Pro Comp recommends that an exhaust shop make modifications or you can purchase part # 51088-20 from your distributor. P/N 51088-20 not compatible with 96 and up trucks or trucks with big blocks.
- ♦ **Note:** A special puller tool is required for safe removal and installation of the torsion adjuster arms. This special puller can be purchased from you local GM dealer (Tool #J36202) or from Kent Moore Tool Group in Roseville, MI. (800) 345-2233 or (313) 774-9500 (Part #J22517-C). You may be able to rent one of these tools at your local parts store. Refer to the GM service manual for more information.

Front Disassembly:

1) Put vehicle in neutral. Place floor jack under the lower control arm's front crossmember and raise vehicle. Place jackstands under the frame rails, behind the front wheel wells, and lower the frame onto the stands. Put vehicle in gear, set emergency brake and block rear wheels, in front and behind tires. Remove front wheels.

NOTE: A special puller tool is required for safe removal and installation of the adjuster arms. This special puller can be purchased from your GM Dealer (Tool #J36202) or from Kent Moore Tool Group, Roseville, MI. (800) 345-2233 or (313) 774-9500 (Part #J22517-C). **WARNING:** Be extremely careful when loading or unloading the torsion bars; there is a tremendous amount of stored energy in the bars. Keep your hands and body clear of the adjuster arm assembly and puller tool in case anything slips or breaks.

2) Make index marks on lower arms and torsion bars. They must be reinstalled in their original side and position. Measure torsion bar adjusting screw depth for replacement of torsion adjuster arm. Remove the torsion bar adjusting screw. Apply a small amount of lubricating grease to the puller threads and the puller shaft-to-adjuster arm contact point. Position puller and load adjuster arm until the adjuster nut can be removed from the crossmember (See ILLUSTRATION 1). With the bar unloaded, slide it further forward into the lower

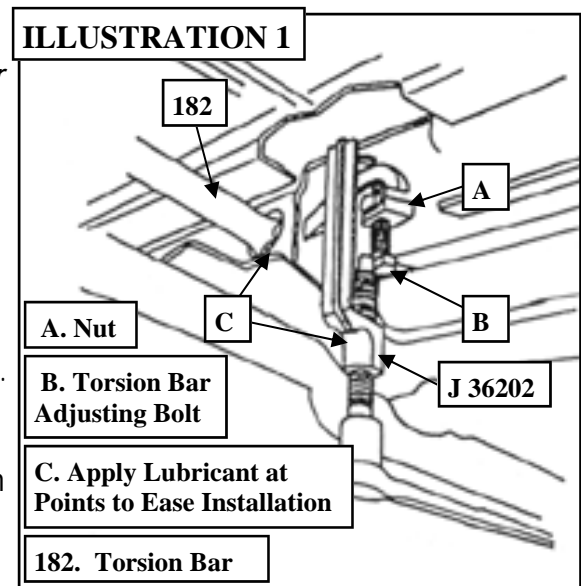
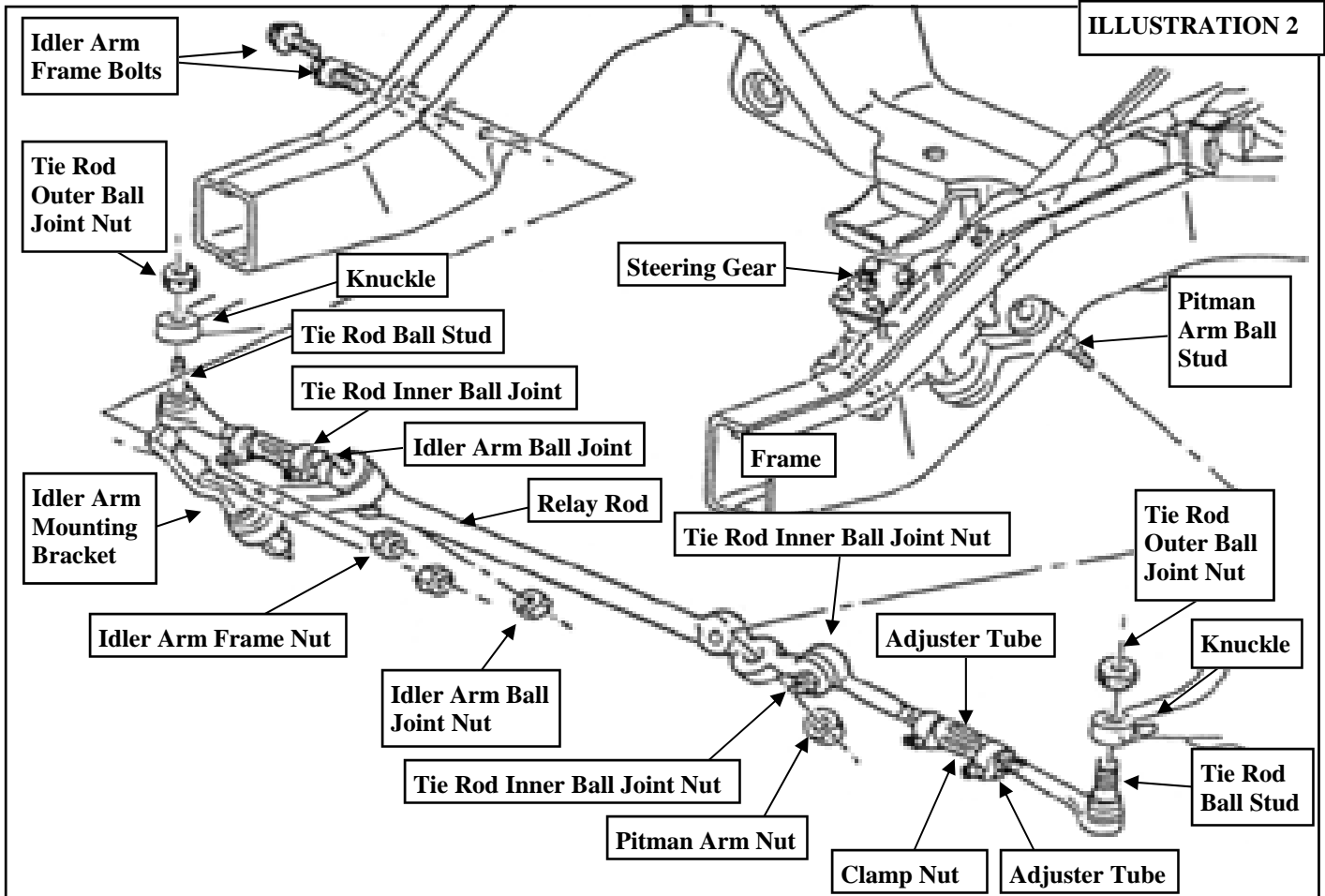

ILLUSTRATION 2



control arm. If the bar seems lodged, use a hammer and punch, through the hole in back of the crossmember. When the bar shifts forward, the adjuster arm will fall free.

Repeat the same procedure on the other side.

3) Remove torsion bar crossmember by removing the 3 bolts per rail that connect it to the frame. It may be necessary to jack up the exhaust to allow clearance for crossmember removal. With the crossmember out of the way, the torsion bars can be dislodged from the lower control arms and removed.

STEPS 4 THROUGH 8 ARE PERFORMED ONE SIDE AT A TIME:

4) At driver side front, locate the rubber brake hose that runs from caliper to frame. Pinch it closed with

ILLUSTRATION 3

USING SUITABLE CUTTING TOOL, CUT OFF AS SHOWN

REAR LOWER DIFFERENTIAL MOUNT (DRIVER SIDE)

WELD IN PLACE 96-1313

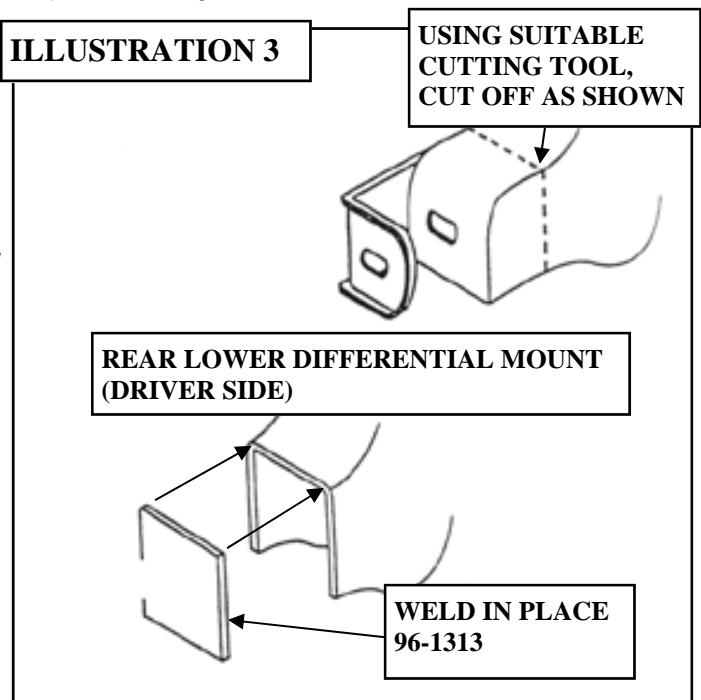

vise grips or a small "c" clamp and detach it from the caliper. Plug or cover the caliper opening to prevent contamination.

NOTE: If your vehicle is equipped with an ABS brake system disconnect the sensor wire and reposition so not to damage the ends.

5) Remove the 6 bolts that attach CV axle to differential.

6) Detach inner end of tie rod from relay rod/centerlink as shown in ILLUSTRATION 2.

7) Remove both anti-sway bar drop links, which connect bar to lower control arms. The links' nuts, accessed through bottom of the arms, are somewhat restricted. It may be necessary to detach the bar at the frame.

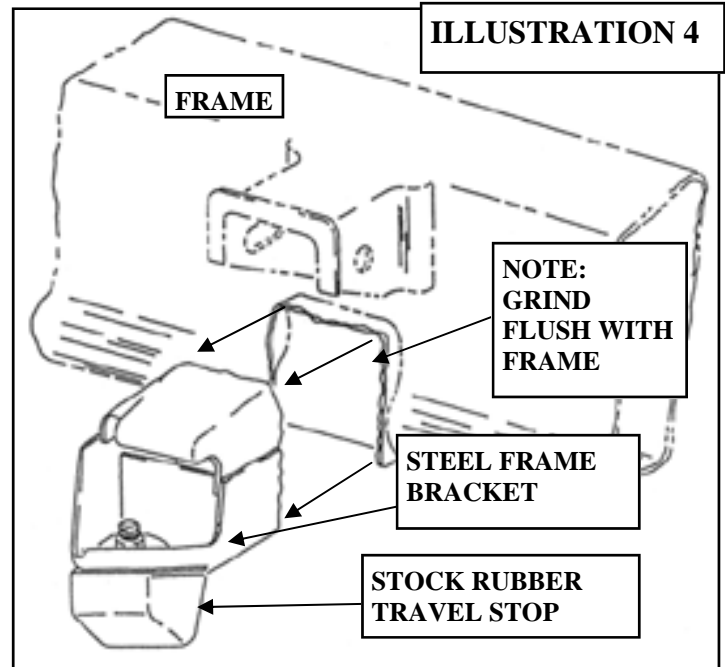

8) Place a floor jack under the hub assembly. Remove upper and lower control arm bolts and lower assembly to floor.

Repeat Steps 4 through 8 on the passenger side.

9) Detach front driveshaft at differential and secure it out of the way.

10) Remove differential skid plate, if vehicle is so equipped.

11) Unplug differentials electronic coupler and vent hose.

12) Remove the bolt that attached the rear of the differential to lower control arm/differential

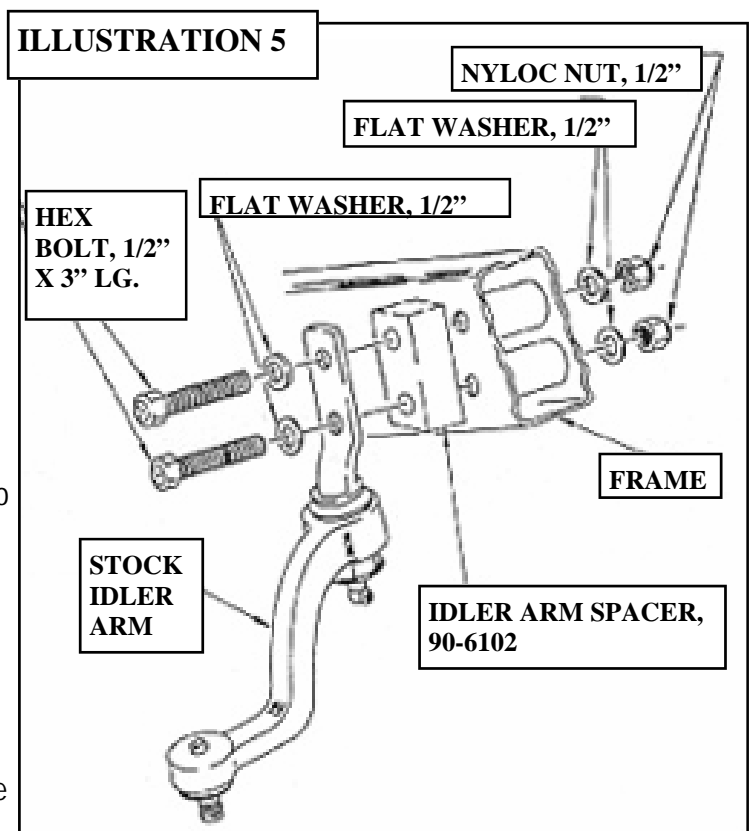

mount. Using a hack saw or suitable cutting tool, cut off driver side rear wrap around differential bracket as shown in ILLUSTRATION 3. This allows differential to drop straight down. After clearance is obtained thru cutting, position and weld differential mount cover plate (96-1313) in place.

13) Position a floor jack under the differential and remove the 3 remaining bolts:

- 1 bolt - differential to top crossmember
- 2 bolts - passenger side axle tube to frame

Now lower assembly to the floor.

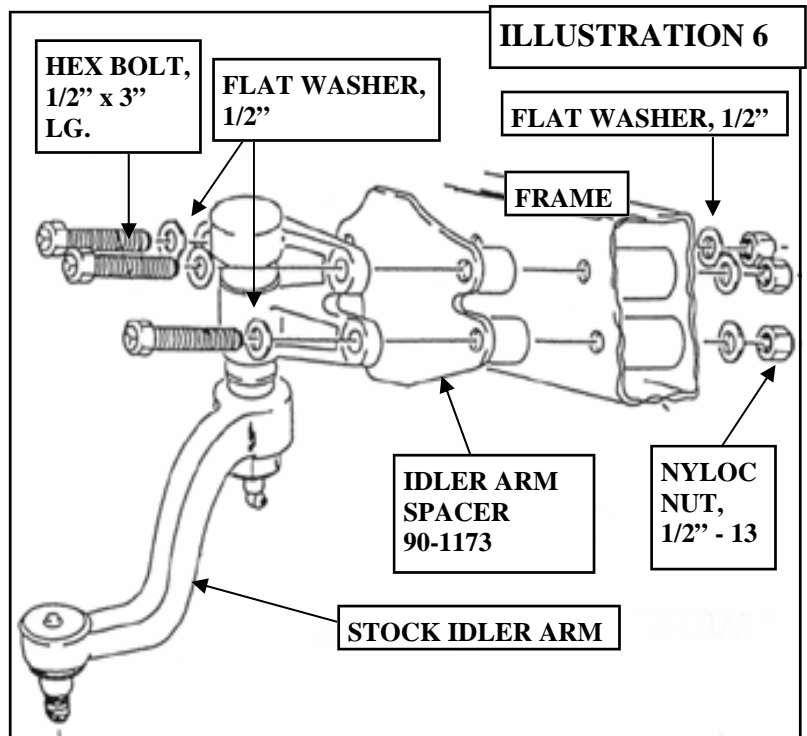

14) On both sides of frame near upper control arm mounts, unbolt the stock rubber compression travel stops from their steel frame mount brackets and discard. With a torch, carefully trim the steel frame mount brackets from the frame as shown in ILLUSTRATION 4. **CAUTION: UNDERCOATING IS FLAMMABLE.** Grind clean all cutting slag from the trimming performed in previous steps. Paint and undercoat exposed metal.

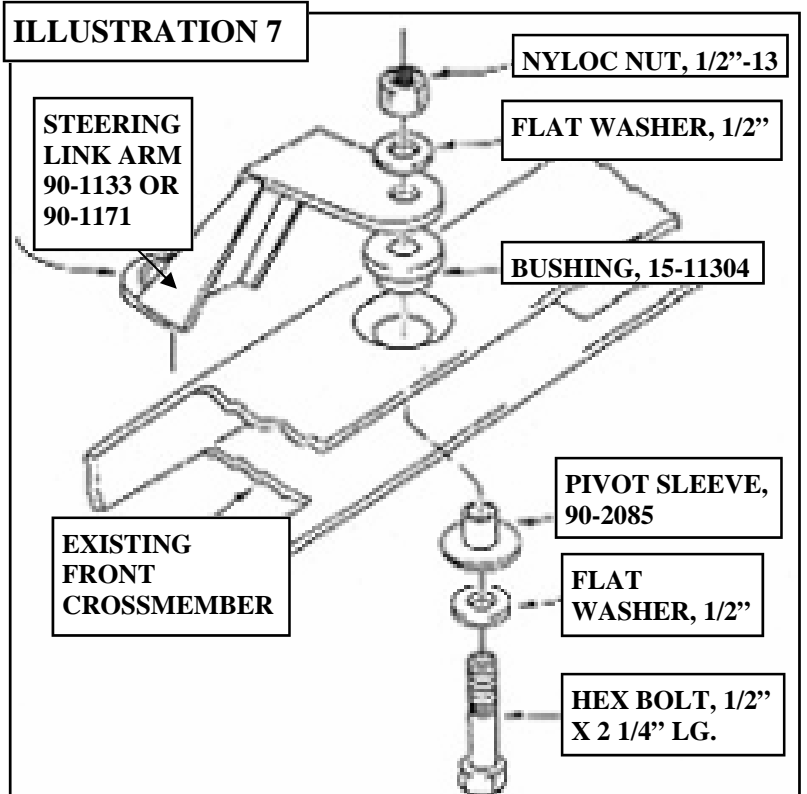

15) Referring back to ILLUSTRATION 2, detach the relay rod/centerlink from the pitman and idler arm studs.

16) Detach the sway bar from the frame. Reinstall reversed or flipped over from its original position.

17) Install idler arm spacer bracket between the idler arm and its frame mounting point. The arm is accessed by removing the passenger side inner fender. Install with supplied bolts, washers and nuts. Use bracket (90-6102) and refer to

ILLUSTRATION 5 for 1988-1992 vehicles, or use bracket (90-1173) and refer to ILLUSTRATION 6 for 1993 and newer vehicles.

18) Install steering link arm (90-1133) or (90-1171) (depending on which vehicle model and crossmember configuration you might have) to existing front crossmember hole location using the hex bolt (1/2" x 2-1/4"), flat washer, pivot sleeve (90-2085), bushing (15-11304) and nyloc nut as shown in ILLUSTRATION 7. When properly installed the top of steering link arm will be parallel to crossmember, and in a nonbinding state. Torque 1/2" nut to 85 ft./lbs.

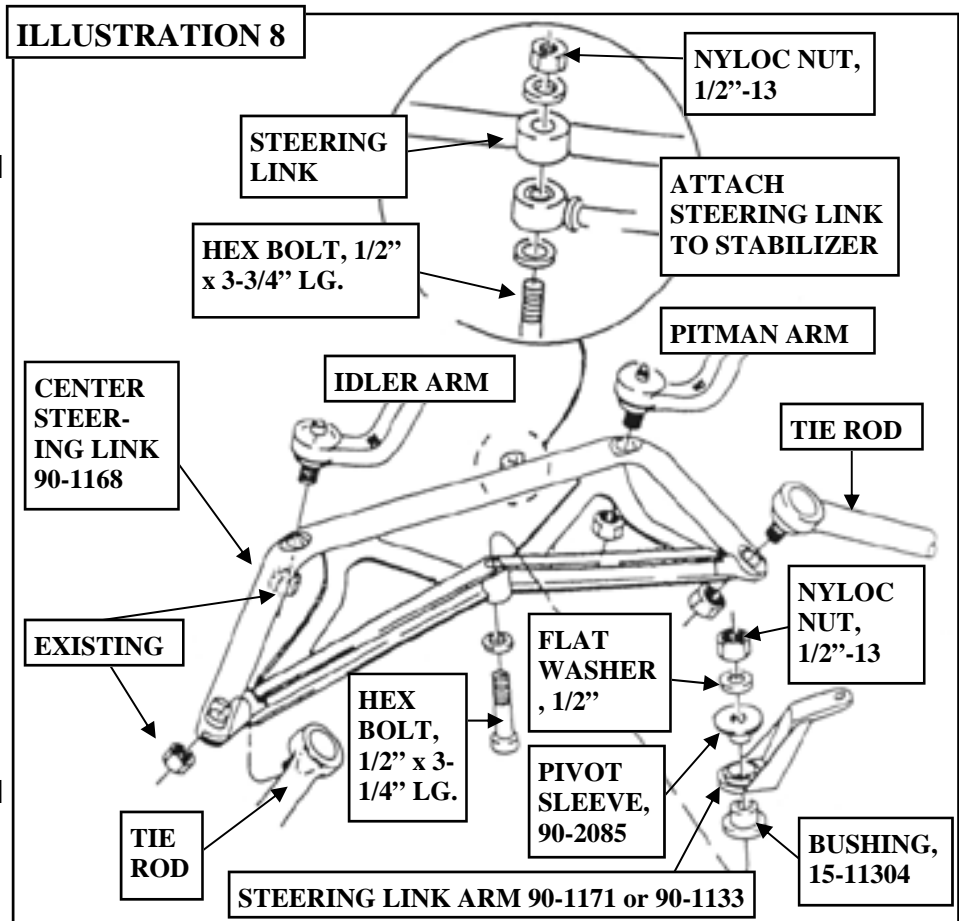

NOTE: Very Important set-up procedure.

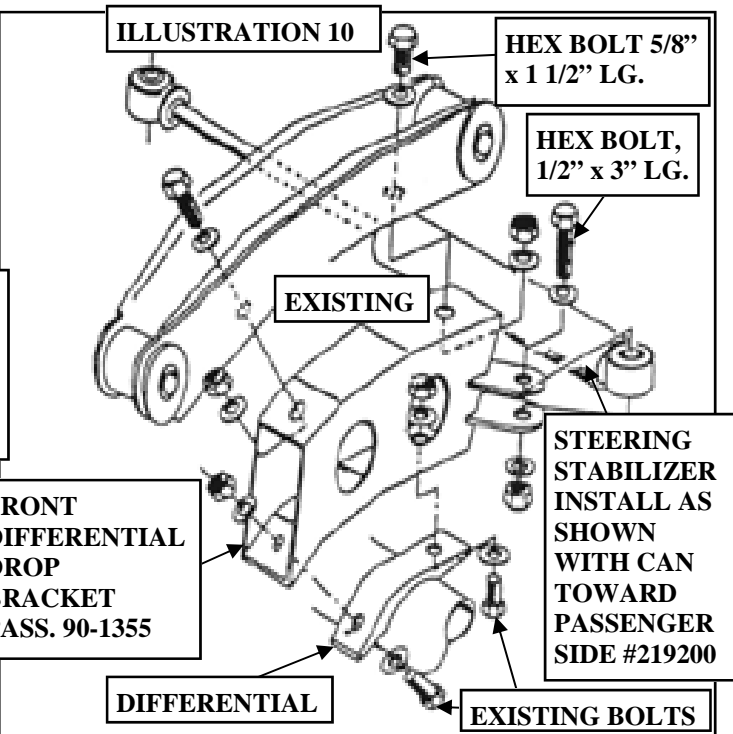
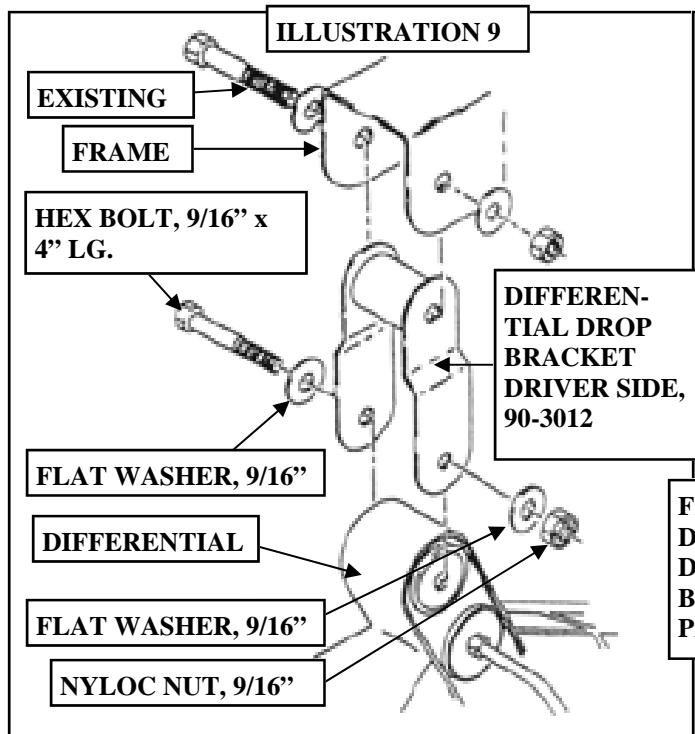

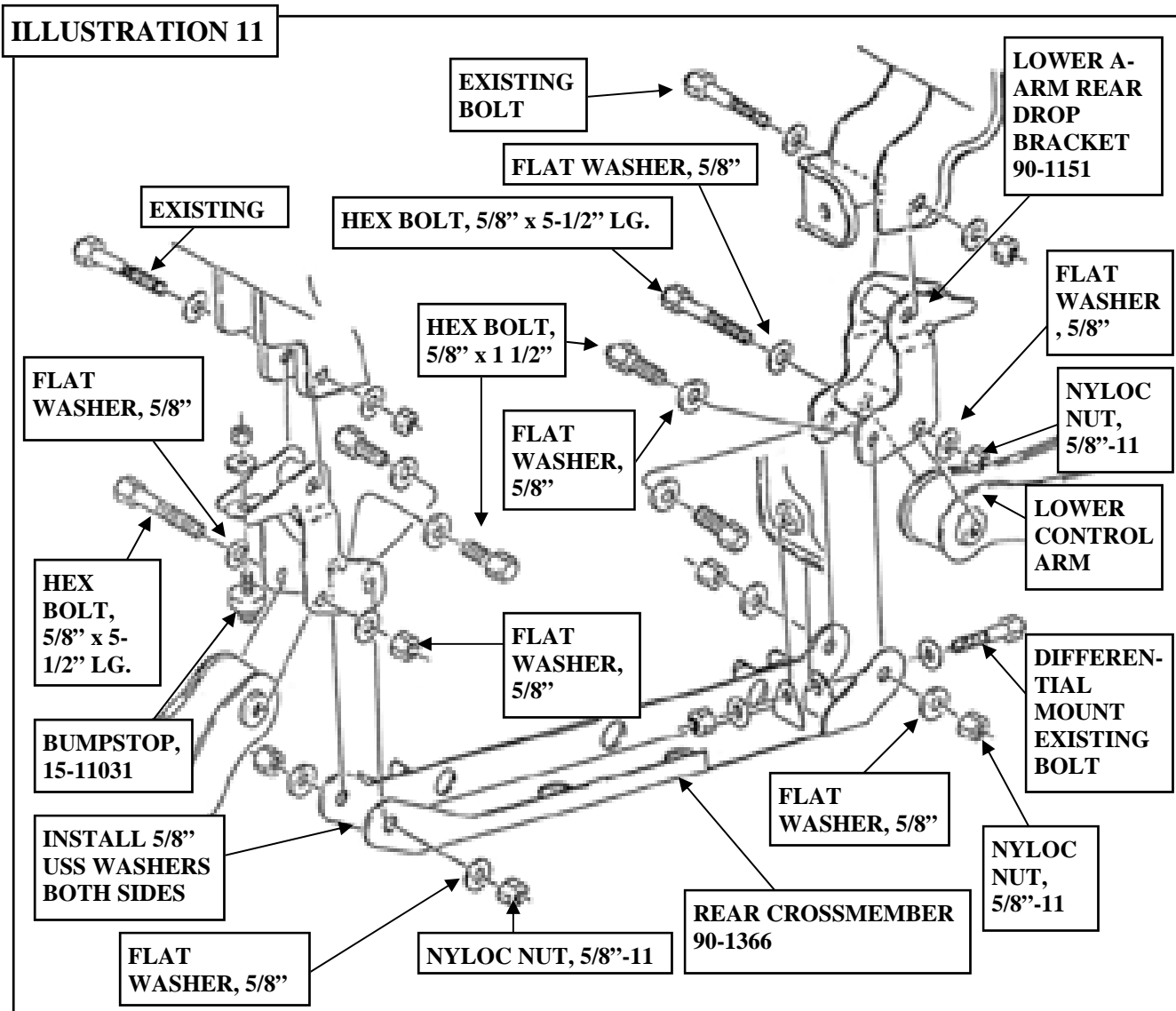

19) Next install center steering link (90-1168) to pitman arm and idler arm. Torque nuts to 48 ft./lbs. Install bushing and pivot sleeve into steering link arm. Position steering link arm over the tube boss on steering link. The hole in the arm should align with the hole in the steering link and the bolt should install with ease. 1/8" misalignment is acceptable if the steering link can be moved by hand to perfect alignment. Remove bolt and turn steering wheel to a full right turn. The holes in the steering link and link arm should align at this point. Repeat this step at a full left turn and check hole alignment again. The 1/2" bolt that secures the steering link arm to the steering link should be in a nonbinding state through the full steering cycle to eliminate undue stress and fatigue on the steering component. If you have problems obtaining this, call PRO COMP at (619) 216-1444.

20) Attach the new steering link arm to the center steering link as shown in ILLUSTRATION 8. Torque 1/2" nut to 85 ft./lbs.

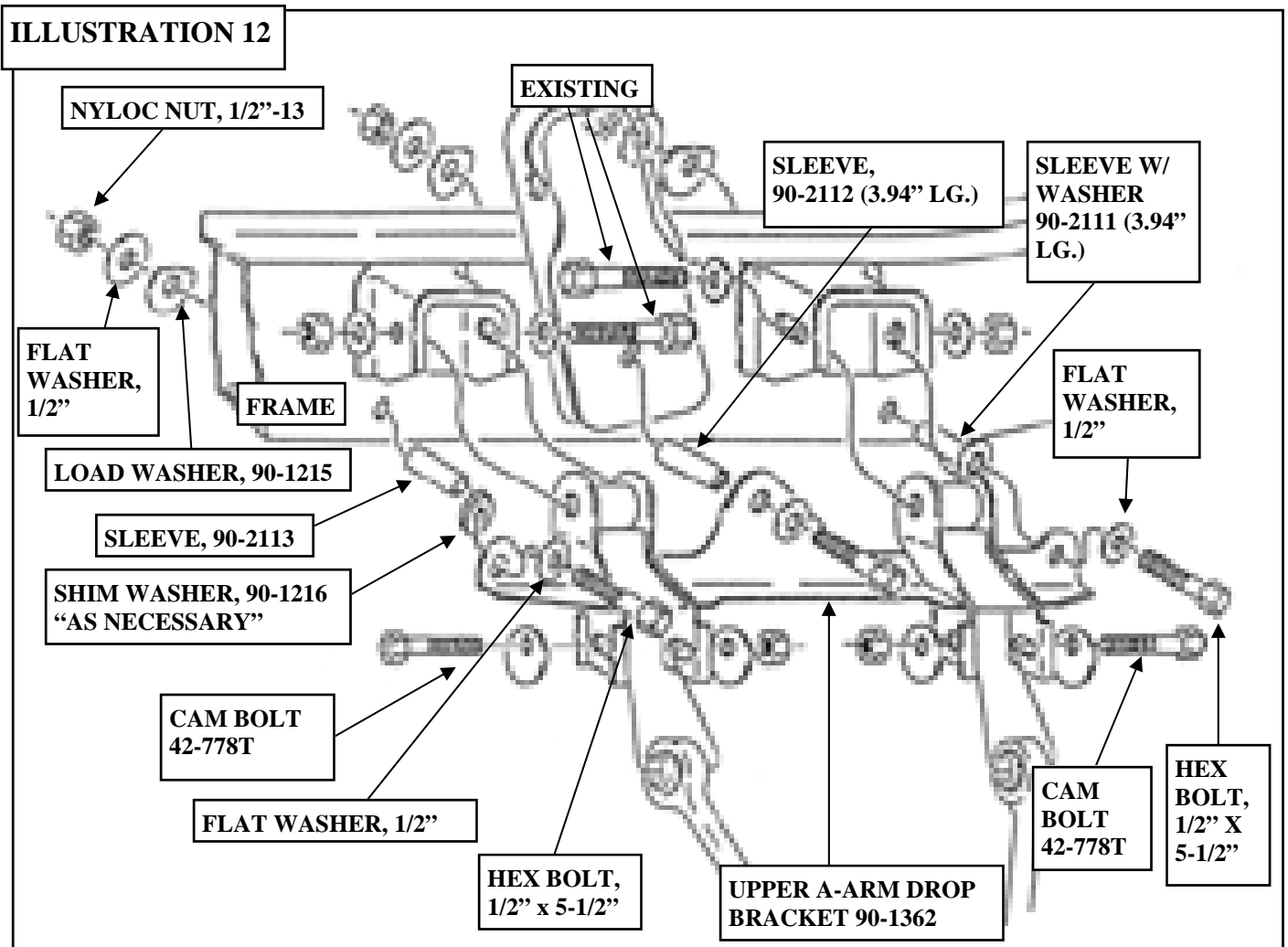

21) Attach the driver side front differential drop bracket (90-3012) to the stock mounting bracket with the existing hardware; finger tighten only (See ILLUSTRATION 9).

22) Attach the passenger side front differential drop bracket (90-1355) to the existing differential support member with the 5/8" hardware supplied (See ILLUSTRATION 10).

23) Raise the differential into position with a floor jack. Attach the driver side front differential drop bracket (90-3012) to the top of the differential with the 9/16" hardware provide (See ILLUSTRATION 9).

NOTE: On some models, the differential case will have to be ground down to provide adequate clearance between case and differential mount.

ILLUSTRATION 13

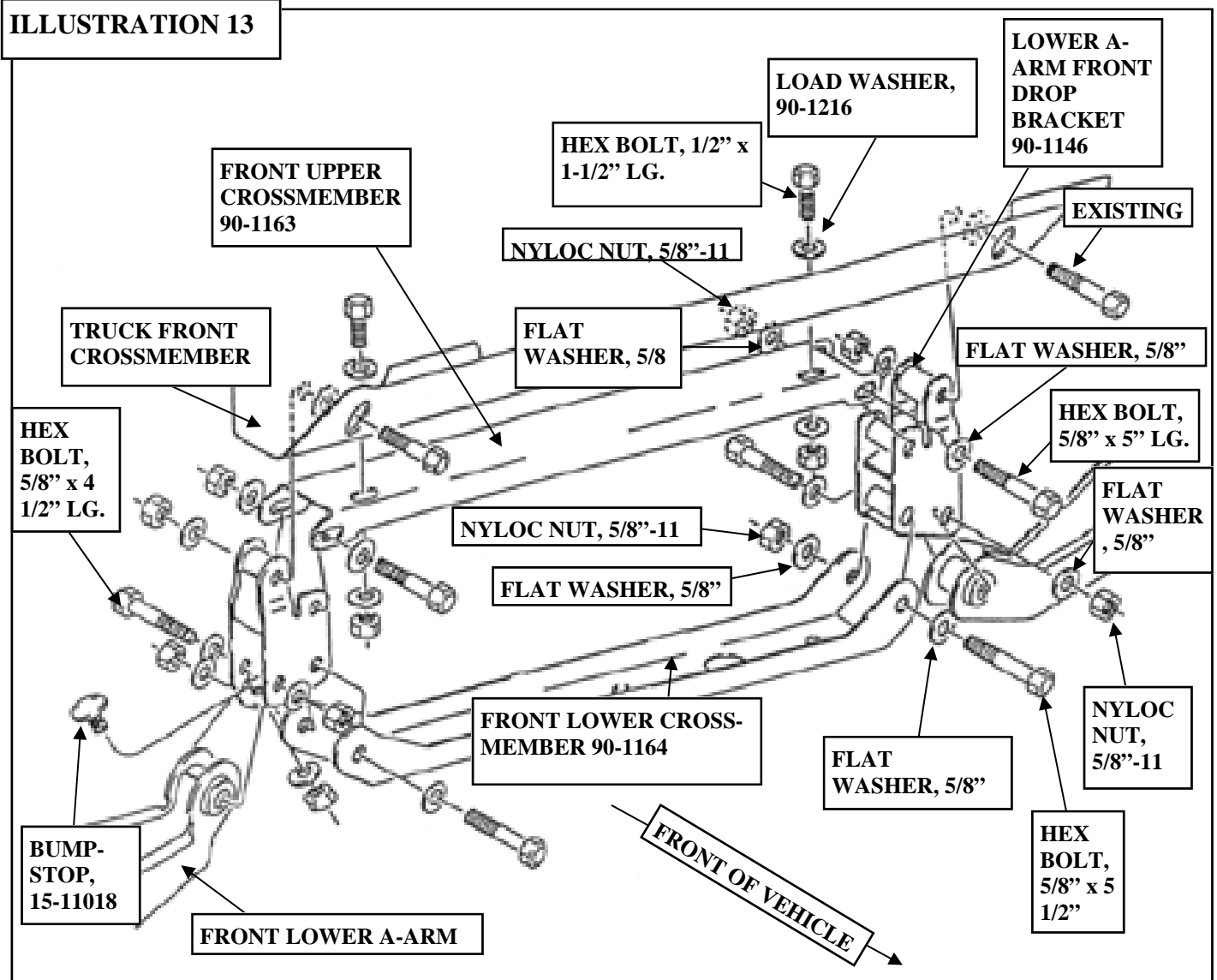

NOTE: It is very important that the differential is centered in the chassis. The best way to accomplish this is to measure the distance from the C.V. flange on the differential to rear lower control arm mounting hole. Compare driver side to passenger side and move differential to center. On some models the cast ribs on the differential case will need to be ground away to provide adequate clearance between case and differential mount.

- Failure to center the differential may cause premature Constant Velocity (C.V.) joint wear or failure.

24) Loosely attach the passenger side of the differential to the passenger side front differential drop bracket (90-1355) with their existing hardware as shown in ILLUSTRATION 10. Install steering, stabilizer (219200) using 1/2" hardware provided.

ILLUSTRATION 14

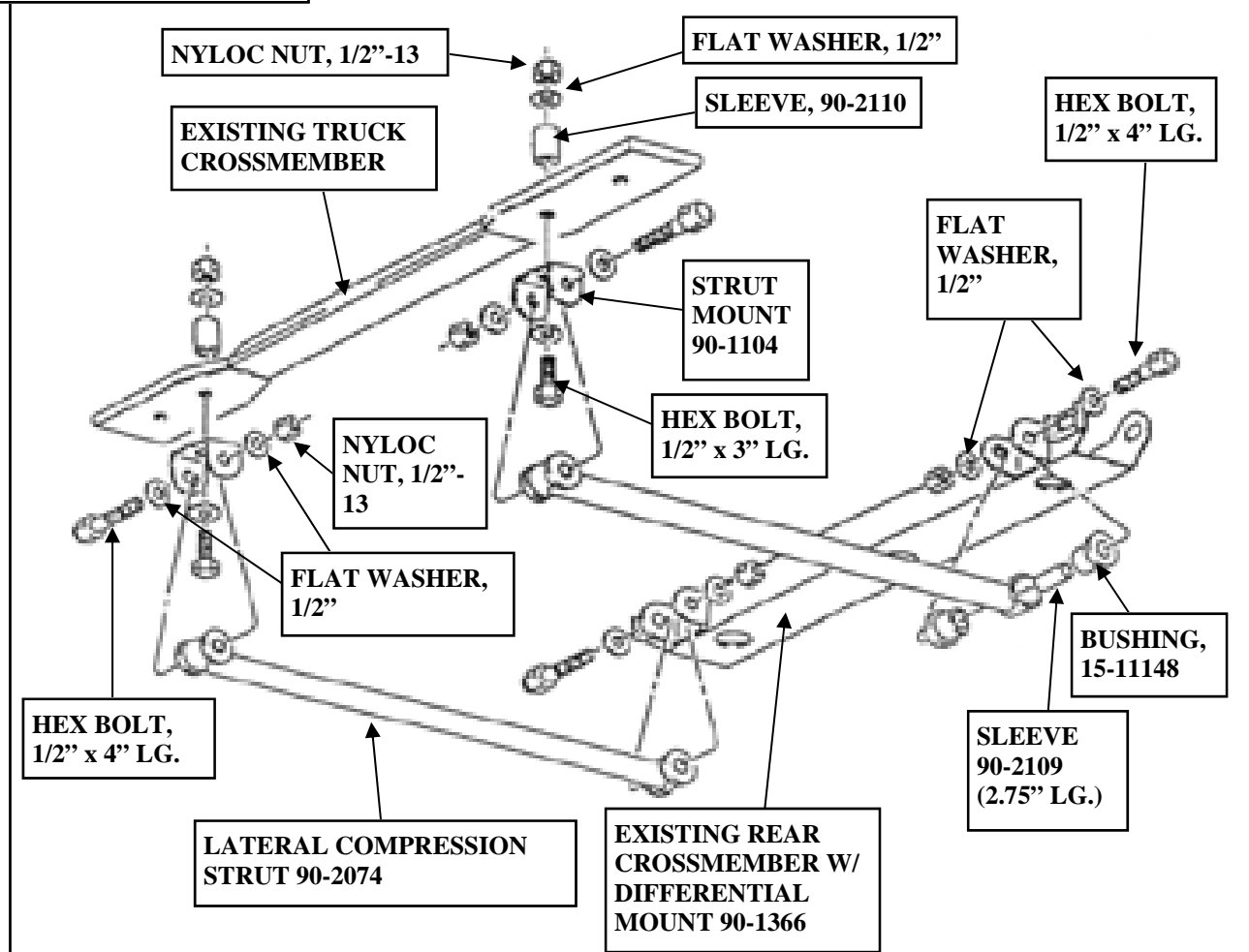

25) Attach lower a-arm rear drop brackets (2) (90-1151) to frame using existing bolts in upper hole on bracket as shown in ILLUSTRATION 11. Be sure the bolts are placed with heads inward toward the axle and threaded end away from axle to allow extra clearance for inner CV joint.

26) Install the rear crossmember (90-1366) as shown in ILLUSTRATION 11, using the 5/8" x 1 1/2" lg. hex bolts and hardware provided. Tighten all differential mount bolts only. Torque according to Specification Chart.

27) Install the driver side upper a-arm drop bracket (90-1362) into the stock a-arm location points and onto the frame. Reference ILLUSTRATION 12 and note the following:

a) Temporarily bolt (or hold tightly) the new upper a-arm drop bracket in place. Use an angle indicator to insure the bracket sits parallel to the frame rail and contacts the frame at the three mounting holes. **CAUTION MUST BE TAKEN NOT TO BEND THE UPPER A-ARM MOUNT WHEN IT IS TORQUED TO THE FRAME.** If it does not fit properly, grind a little more where the bump stop was cut off. (It is

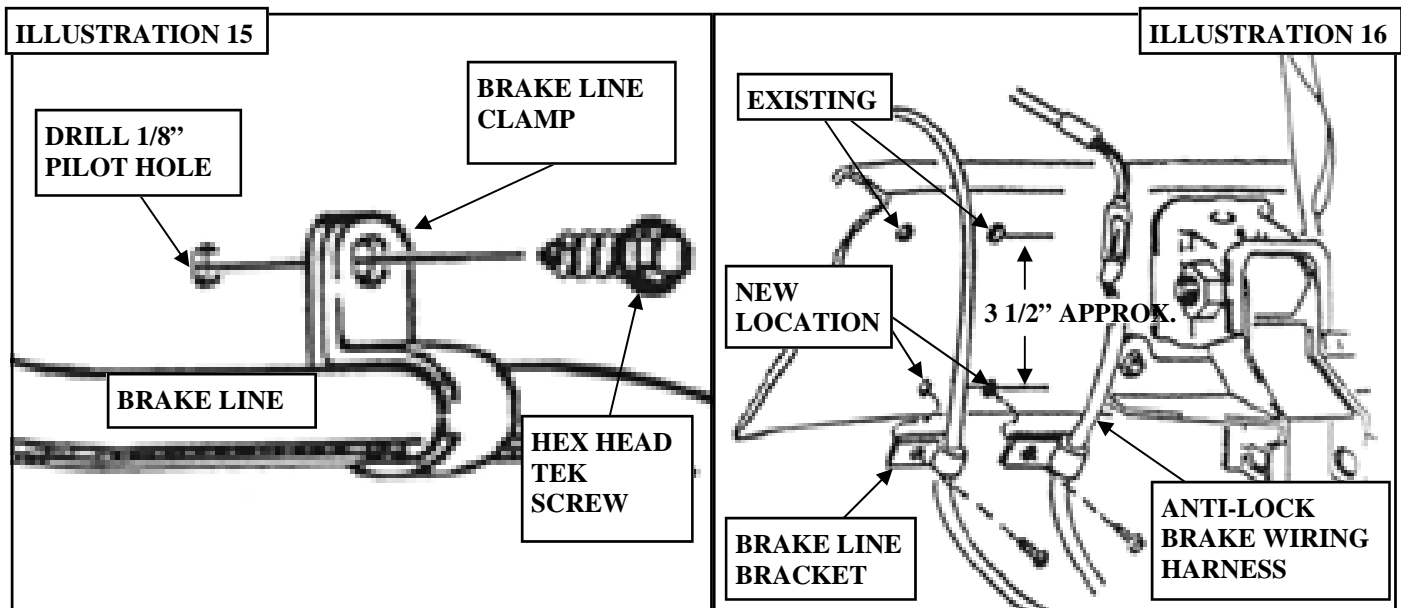

important to have the vehicle sitting level side-to-side on jackstands before starting this project).

b) Once positioned, use the upper a-arm drop bracket as a guide to drill the necessary holes in the frame.

c) Enlarge the two holes in the outer face only of the frame to **3/4"** so that the anti-crush sleeves (**90-2112 and 90-2113**) can be inserted into them. The holes on the backside are only large enough for the bolts to protrude, not the sleeves. The sleeves are trapped between the inner frame wall and the drop bracket. The sleeves prevent the frame from crushing when the bracket's bolts are torqued to specifications during final assembly.

NOTE: *If you are installing a Pro Comp shock hoop, install it at this time.*

d) Install the upper a-arm drop bracket into the original bracket slots using the hardware provided as outlined in ILLUSTRATION 12.

Repeat Step 27 on the Passenger Side:

28) Install bump stop (**15-11018**) onto lower a-arm front drop bracket (**90-1146**) as shown in ILLUSTRATION 13. Install the lower a-arm front drop brackets (**90-1146**) to the frame using the existing hardware as shown in ILLUSTRATION 13.

29) Bolt the front upper crossmember (**90-1163**) to the lower a-arm drops. Install the **1/2" x 1-1/2"** bolts,

washers and nuts as shown in ILLUSTRATION 13 into the frame. Due to manufacturing differences in the stock crossmember, washers may be required between 90-1163 and the frame to properly tighten the 1/2" bolts without deforming the 90-1163 upper crossmember.

30) Attach the front lower crossmember (90-1164) to the lower inside holes of the lower a-arm front drop bracket (90-1146) using the 5/8" x 5-1/2" hex bolts provided. See Torque Specification Chart at end of the instructions.

31) Re-hang control arms. Start at the driver side. Both sides install identically. Raise the control arm assembly into position with a floor jack. Install with 5/8" hardware at the lower control arm attaching point.

Use 5/8" bolts facing forward on front leg and facing rearward leg as shown in ILLUSTRATION 13.

Now attach upper control arm to brackets per ILLUSTRATION 12. Be sure that the anti-sway bar body is pivoted down so it is below the upper control arm's front leg.

Install new eccentric cam bolt kit (90-6170) and adjust bolts to a neutral, or centered position (torque to 75 ft./lbs).

32) Attach CV axle flange to differential. Use loctite and torque to 60 ft./lbs.

33) Pro Comp's kit incorporates two traction bar-like rod called lateral compression struts, (90-2074), that bolt to the rear a-arm crossmember and extend to the next chassis crossmember (See ILLUSTRATION 14).

These struts eliminate for and aft movement of the front differential.

NOTE: Sleeve (90-2110) fits inside the crossmember, preventing the frame from crushing when the bolts are torqued to specifications.

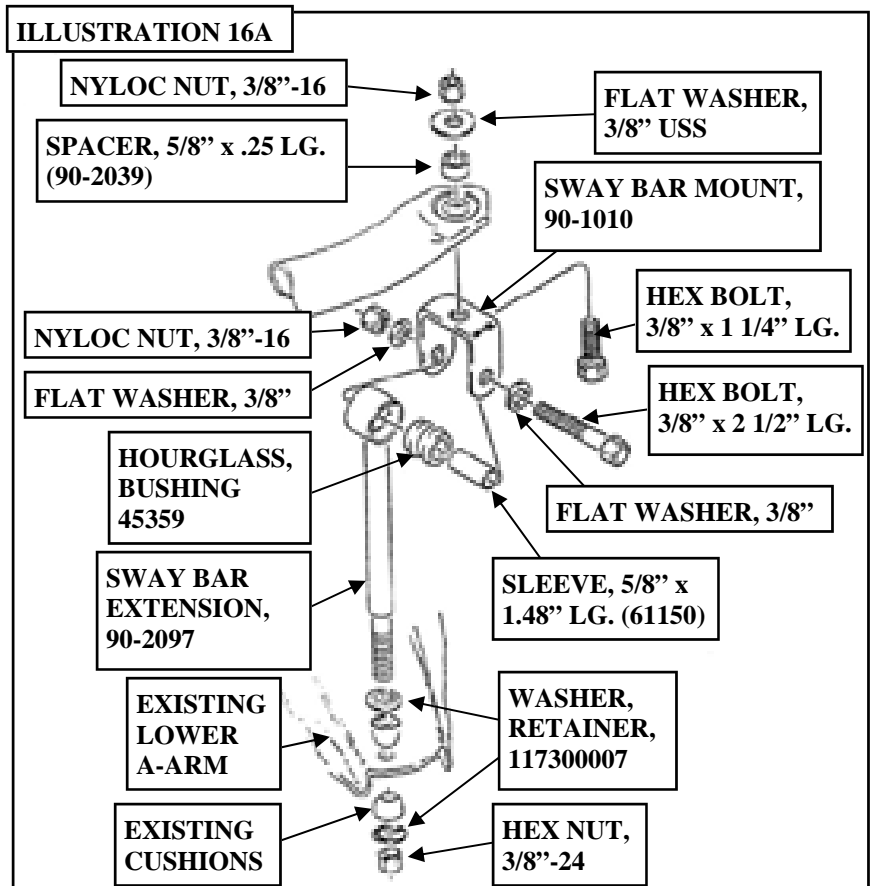

34) Position brake hoses so they don't make contact with other parts. Refer to ILLUSTRATION 15 & 16.

35) Install the front shock absorbers (322501 or 324501). Torque upper and lower bolts to 66 ft./lbs. Cycle suspension through the full travel cycle and check for adequate clearance between shocks, bump stops and brake hoses. Brake hose should be routed behind shocks. (On '97 and later models it may be necessary to invert shock to avoid interference with upper control arm). Use 90-6085 parts pack for 10 new bushing.

NOTE: The 51894 kit incorporates the use of limiting straps that limit the down travel of the cast steel front lower a-arms.

When installing the front shock absorbers (322501), attach the 2-1/4" long bushing and sleeve supplied, into the top shock loop. Install 1-3/8" long bushing and sleeve into the bottom shock loop. Using existing hardware as shown in ILLUSTRATION 17A, attach the top of shock absorber and limit strap (5213-1) to the inside of upper shock tower, then fasten the lower limit strap to outside of existing lower shock mount. Torque nuts to 66 ft./lbs.

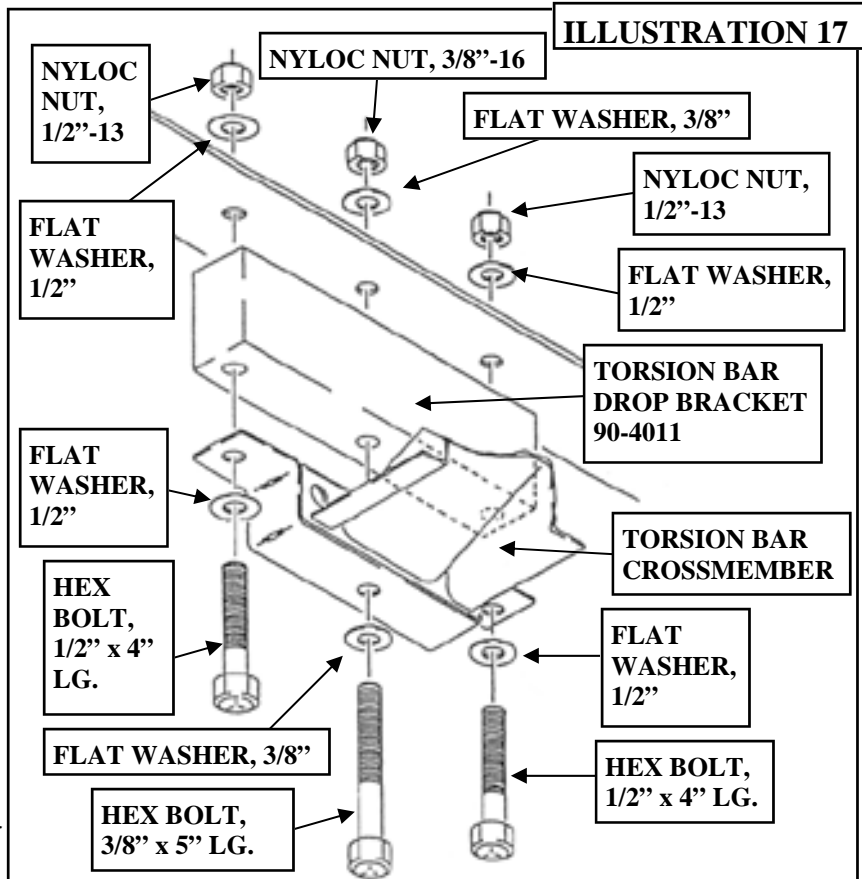

36) Reinstall the differential vent hose. Reconnect the electrical plug.

37) Install the front anti-sway bar drop links (90-6064). Both sides install identically. Tighten drop link bolt just until bushing swell slightly. Install components of 90-6064 see illustration 16A. Torque 3/8" mounting hardware to 28 ft./lbs.

38) Reinstall the front driveshaft. If it does not clear the exhaust crossover pipe, reroute a new section of pipe either above or below the shaft. If necessary, the vehicle can be driven with front shaft completely removed. Torque the shaft to differential bolts to 15 ft./lbs.; torque the shaft to TFC bolts to 74 ft./lbs.

NOTE: The drive shaft needs to be reversed on '94-'95 vehicles equipped with front drive shafts, utilizing u-joints at both ends.

RECHECK CLEARANCES:

39)With vehicle still on jack stands and suspension hanging at full extension travel, cycle steering lock to lock to check all components for proper operation and clearance. Tighten to required torque specifications per chart at end of instructions. Pay close attention to the brake hose clamp on the top of the spindle. Do not crush the clamp between the spindle and the upper control arm.

40)Insert torsion bars into the lower control arms. The bar's rear facing ends are now hanging. This step is a 2-man operation. Balance the crossmember on a floor jack and raise it to mate with the hanging bar ends. Now locate the adjuster arms inside the crossmember and onto the bar ends.

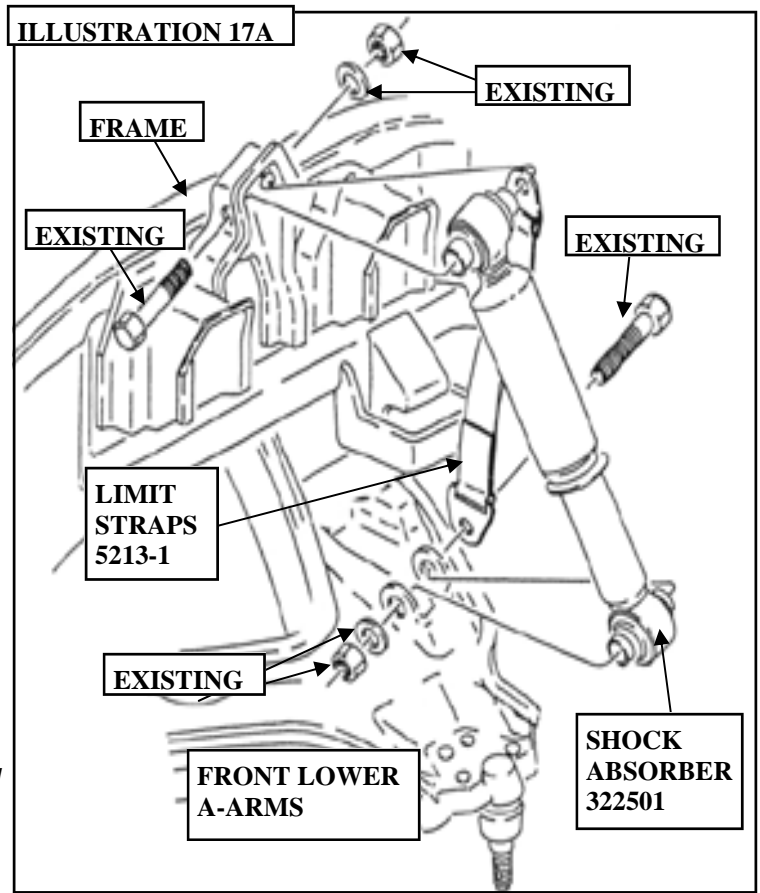

41)After the torsion bar crossmember is removed and it's brackets are flipped so they mount under the frame, install the new aluminum torsion bar drop bracket (**90-4011**) as shown in ILLUSTRATION 17.

Torsion bars are marked "left" and "right" and the torsion bar adjusting bolt's exposed length is measured before removal. This way they can be reinstalled to the stock position.

42)Load the torsion bars reversing the sequence of INSTRUCTION 2, again being very careful. Tighten adjusting bolts until exposed length matches original measurement. This initial setting will be re-adjusted later.

AT THIS TIME GO THROUGH AND TIGHTEN/TORQUE ALL BOLTS TO REQUIRED SPECIFICATIONS ACCORDING TO THE SPEC CHART AT THE END OF THE INSTRUCTIONS. DO NOT RETIGHTEN BOLTS WHERE LOCTITE WAS USED.

43)As shown in ILLUSTRATION 18 place the riser blocks into position, making sure the pin in the block is in the hole of the axle housing spring pad. The short end of the block goes toward the front of the vehicle. Install the block so the pinion moves up.

44) Raise the axle housing up until the pin in the spring aligns with the hole in the block.

45) Remount the axle to the spring using the new u-bolts washers and nuts and the existing spring plates; tighten and torque u-bolt nuts to 85-110ft./lbs.

46) Reconnect axle vent hose and install rear shock absorbers (329500).

47) Install the wheels and lower vehicle.

48) After the rear lift is complete, a final ride height adjustment should be performed. Manually bounce the front and rear of the vehicle to pre-settle the bars and springs. Evenly adjust-up the torsion bar bolts until the front of the vehicle is approximately 1/2" above the final desired ride height. Bars will settle slightly after vehicle is driven.

NOTE:

1) Each bar may require slightly different adjustment to level vehicle side to side.

2) At maximum ride height, there still must be at least 3/16" of clearance between the bump stop and the front lower control arm. Operating the vehicle with less bump stop clearance will result in a harsh ride and accelerated suspension component wear.

SOME FINAL NOTES:

- After installation is complete, double check that all nuts and bolts are tight. Refer to the chart below for torque specifications. (Do not retighten nuts and bolts where Loctite was used).

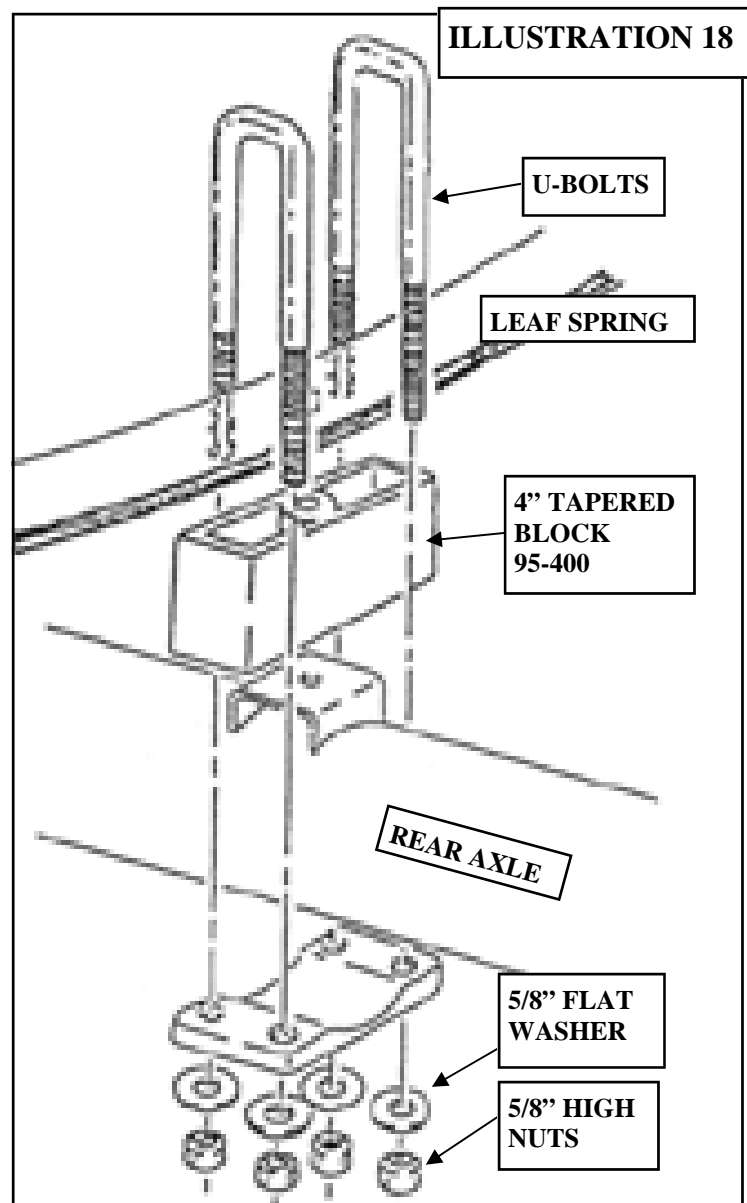

- If new tires are installed that are more than 10% taller than original tires, the speedometer must be recalibrated for the rear wheel anti-lock brake system to function properly. Contact an authorized GM dealer for details on recalibration.
- With vehicle on the floor, cycle steering lock to lock and inspect steering, suspension and driveline systems for proper operation, tightness and adequate clearance. Recheck brake hose/fittings for leaks. Be sure all hoses are long enough.
- Have headlights readjusted to proper settings.
- Realign front end to factory specifications. Be sure vehicle is at desired ride height prior to realignment.
- On some vehicles it may be difficult to obtain factory caster due to torsion bar settings. On these vehicles it is most important to get a castor split of 1/4 degree move, positive caster on passenger side. This will keep vehicle from pulling.
- If you cannot get vehicle within proper camber settings and you have torsions set properly. Make sure lower control arms are not shifted to one side of vehicle. It is very important that lower control arms be dropped directly below original mounting points. There is not enough adjustment in upper control arms to compensate for a kit that has been installed off to one side of the vehicle. It is imperative that lower drops are installed properly.

Use this only as a guide for hardware without a called out torque specification in the instruction manual.

Bolt Torque and ID						
Decimal System			Metric System			
All Torques in Ft. Lbs. Maximums						
Bolt Size	Grade 5	Grade 8	Bolt Size	Class 9.8	Class 10.9	Class 12.9
5/16	15	20	M6	5	9	12
3/8	30	45	M8	18	23	27
7/16	45	60	M10	32	45	50
1/2	65	90	M12	55	75	90
9/16	95	130	M14	85	120	145
5/8	135	175	M16	130	165	210
3/4	185	280	M18	170	240	290

1/2-13x1.75 HHCS D T L X	Grade 5 Grade 8 (No. of Marks + 2)	M12-1.25x50 HHCS D T L X	

G = Grade (Bolt Strength) D = Nominal Diameter (Inches) T = Thread Count (Threads per Inch) L = Length (Inches) X = Description (Hex Head Cap Screw)	P = Property Class (Bolt Strength) D = Nominal Diameter (Millimeters) T = Thread Pitch (Thread Width, mm) L = Length (Millimeters) X = Description (Hex Head Cap Screw)
--	---

Notice to Owner operator, Dealer and Installer:

Vehicles that have been enhanced for off-road performance often have unique handling characteristics due to the higher center of gravity and larger tires. This vehicle may handle, react and stop differently than many passenger cars or unmodified vehicles, both on and off-road. You must drive your vehicle safely! Extreme care should always be taken to prevent vehicle rollover or loss of control, which can result in serious injury or even death. Always avoid sudden sharp turns or abrupt maneuvers and allow more time and distance for braking! Pro Comp reminds you to fasten your seat belts at all times and reduce speed! We will gladly answer any questions concerning the design, function, maintenance and correct use of our products.

Please make sure your Dealer/Installer explains and delivers all warning notices, warranty forms and instruction sheets included with Pro Comp product.

Application listings in this catalog have been carefully fit checked for each model and year denoted. However, Pro Comp reserves the right to update as necessary, without notice, and will not be held responsible for misprints, changes or variations made by vehicle manufacturers. Please call when in question regarding new model year, vehicles not listed by specific body or chassis styles or vehicles not originally distributed in the USA.

Please note that certain mechanical aspects of any suspension lift product may accelerate ordinary wear of original equipment components. Further, installation of certain Pro Comp products may void the vehicle’s factory warranty as it pertains to certain covered parts; it is the consumer’s responsibility to check with their local dealer for warranty coverage before installation of the lift.

Warranty and Return policy:

Pro Comp warranties its full line of products to be free from defects in workmanship and materials. Pro Comp’s obligation under this warranty is limited to repair or replacement, at Pro Comp’s option, of the defective product. Any and all costs of removal, installation, freight or incidental or consequential damages are expressly excluded from this warranty. Pro Comp is not responsible for damages and / or warranty of other vehicle parts related or non-related to the installation of Pro Comp product. A consumer who makes the decision to modify his vehicle with aftermarket components of any kind will assume all risk and responsibility for potential damages incurred as a result of their chosen modifications. Warranty coverage does not include consumer opinions regarding ride comfort, fitment and design. Warranty claims can be made directly with Pro Comp or at any factory authorized Pro Comp dealer.

IMPORTANT! To validate the warranty on this purchase please be sure to mail in the warranty card.

Claims not covered under warranty-

- Parts subject to normal wear, this includes bushings, bump stops, ball joints, tie rod ends and heim joints
 - Discontinued products at Pro Comp’s discretion
- Bent or dented product
- Finish after 90 days
- Leaf or coil springs used without proper bump stops
- Light bulbs
- Products with evident damage caused by abrasion or contact with other items
- Damage caused as a result of not following recommendations or requirements called out in the installation manuals
- Products used in applications other than listed in Pro Comp’s catalog
- Components or accessories used in conjunction with other manufacturer’s systems
- Tire & Wheel Warranty as per Pro Competition Tire Company policy
- Warranty claims without “Proof of Purchase”
- Pro Comp Pro Runner coil over shocks are considered a serviceable shock with a one-year warranty against leakage only. Rebuild service and replacement parts will be available and sold separately by Pro Comp. Contact Pro Comp for specific service charges.
- Pro Comp accepts no responsibility for any altered product, improper installation, lack of or improper maintenance, or improper use of our products.

E-Mail: tech@explorerprocomp.com
Website: www.explorerprocomp.com
Fax: (619) 216-1474
Ph: (619) 216-1444

PLACE
WARRANTY REGISTRATION
NUMBER
HERE: _____