

2360 Boswell Road  
Chula Vista, CA 91914  
Phone 619.216.1444  
Fax 619.216.1474  
E-Mail tech@explorerprocomp.com



## PRO COMP SUSPENSION

---

Suspension Systems that Work!

**Part # 51494**  
**1988 - 1998 Chevrolet / GMC**  
**1/2 ton, 4 X 4**  
**4 Inch Suspension System**

This document contains very important information that includes warranty information and instructions for resolving problems you may encounter. Please keep it in the vehicle as a permanent record.

## Box 1 of 4-PN 51494-1

Part #	Description	Qty.	Illus.	Page
90-1312	FRONT CROSS MEMBER	1	6, 8	8, 9
<b>90-6228</b>	<b>HARDWARE PACK, CROSS MEMBER</b>	<b>1</b>		
70-06245001800	5/8" X 4 1/2" GR 8 HEX BOLT	2	12	11
70-0625501800	5/8" X 5 1/2" GR 8 HEX BOLT	2	12	11
72-062100816	5/8" USS GR 8 STOVER NUT	4		
73-06200034	5/8" SAE GR 8 FLAT WASHER	8		
90-2305	CENTER LINK DROP	1	8	9
<b>90-6229</b>	<b>HARDWARE PACK, CENTER LINK DROP</b>	<b>1</b>		
70-0504501800	1/2" X 4 1/2" GR 8 HEX BOLT	2	8	9
70-0502501800	1/2" X 2 1/2" GR 8 HEX BOLT	2	6	8
72-050100816	1/2" USS GR 8 STOVER NUT	4		
73-05000034	1/2" SAE GR 8 FLAT WASHER	4		
73-05000039	1/2" AN GR 8 FLAT WASHER	8	8	9
<b>90-6231</b>	<b>HARDWARE PACK, CENTER LINK</b>	<b>1</b>		
90-4053	STEERING LINK SUPPORT	2	6	8
90-2180	SPACER, 1 1/2" OD X .531" ID X 1/2" LONG	2	8	9
90-2014	SPACER, 3/4" OD X 1/2" ID X 1/4" LONG	2	6	8
90-2309	SPACER, 1 1/2" OD X .531" ID X 1" LONG	2	8	9
90-4036	REDUCER CONE	4	8	9
<b>90-6254</b>	<b>HARDWARE PACK, BRAKELINE RELOCATION</b>	<b>1</b>		
90-1758	BRAKELINE RELOCATION BRACKET	2	15	12
70-0311001800	5/16" X 1" GR 8 HEX BOLT	4	15	12
72-031100816	5/16" USS GR 8 STOVER NUT	4		
73-03100034	5/16" SAE GR 8 FLAT WASHER	8		

## Box 2 of 4-PN 51494-2

90-1498	UPPER A-ARM DROP BRACKET, DRIVER	1	5	7
90-1499	UPPER A-ARM DROP BRACKET, PASSENGER	1	5	7
<b>90-6078</b>	<b>HARDWARE PACK, UPPER A-ARMS</b>	<b>1</b>		
70-0505501800	1/2" X 5 1/2" GR 8 HEX BOLT	6	5	7
72-050100816	1/2" USS GR 8 STOVER NUT	6		
73-05000034	1/2" SAE GR 8 FLAT WASHER	12		
90-1655	DIFFERENTIAL DROP BRACKET, DRIVER	1	9	10
90-1657	DIFFERENTIAL DROP BRACKET, PASSENGER	1	7	8
90-2303	DIFFERENTIAL TORQUE TUBE	1	9	10
<b>90-6226</b>	<b>HARDWARE PACK, DIFFERENTIAL</b>	<b>1</b>		
70-0561251800	9/16" X 1 1/4" GR 8 HEX BOLT	3	7, 9	8, 10
70-0564001800	9/16" X 4" GR 8 HEX BOLT	1	9	10
72-056100816	9/16" USS GR 8 STOVER NUT	4		
73-05600034	9/16" SAE GR 8 FLAT WASHER	6		
73-05600042	9/16" USS GR 8 FLAT WASHER	2	7	8
90-6100	SWAY BAR END LINK KIT	1		
<b>90-6082</b>	<b>HARDWARE PACK, CAMBOLT</b>	<b>1</b>		
13-90386	CAMBOLT ASSEMBLY	4	13	11
<b>90-6083</b>	<b>HARDWARE PACK, UPPER A-ARM DROPS</b>	<b>1</b>		
90-1215	LOAD WASHER, 2" OD X .550" ID	6	5	7
90-1216	LOAD WASHER, 1 1/2" OD X .532" ID	2	5	7
90-2111	SLEEVE WITH WASHER	2	5	7
90-2112	SLEEVE, 3/4" X 1/2" X 3.940"	2	5	7
90-2113	SLEEVE, 3/4" X 1/2" X 3.440"	2	5	7
90-350	3 1/2" CAST IRON LIFT BLOCK	2	17	13

## Box 3 of 4-PN 51494-3

90-1128	REAR CROSS MEMBER	1	10	10
90-2126	COMPRESSION STRUT	2	15, 16	12
90-1104	COMPRESSION STRUT MOUNT	2	15, 16	12
96-1313	WELD IN PLATE	1	2	6
<b>90-6230</b>	<b>HARDWARE PACK, COMPRESSION STRUTS</b>	<b>1</b>		
70-0504001800	1/2" X 4" GR 8 HEX BOLT	4	15, 16	12

Part #	Description	Qty.	Illus.	Page
70-0503001800	1/2" X 3" GR 8 HEX BOLT	4	14	11
72-050100816	1/2" USS GR 8 STOVER NUT	8		
73-05000034	1/2" SAE GR 8 FLAT WASHER	16		
70-0374001800	3/8" X 4" GR 8 HEX BOLT	2	14	11
72-037100816	3/8" USS GR 8 STOVER NUT	2		
73-03700034	3/8" SAE GR 8 FLAT WASHER	4		
<b>90-6148</b>	<b>HARDWARE PACK, URETHANE PARTS</b>	<b>1</b>		
15-11018	LOW-PROFILE BUMP STOP	2	10	10
15-11031	CONE BUMP STOP	2	10	10
15-11304	BUSHING, PIVOT SLEEVE	2		
15-11148	COMPRESSION STRUT BUSHING	8	15, 16	12
90-2085	PIVOT SLEEVE	2		
90-2109	SLEEVE, COMPRESSION STRUT	4	15, 16	12
90-2110	SLEEVE	2	16	12
72-037100512	3/8" GR 5 NYLOCK NUT	4	10	10
90-4018	TORSION BAR DROP SPACER	2	14	11
13-90087	U-BOLT, SQUARE, 9/16"-18	4	17	13
<b>20-65302</b>	<b>HARDWARE PACK, U-BOLT</b>	<b>1</b>		
13-30330	9/16" HARDENED FLAT WASHER	8		
13-10423	9/16" HI-NUT	8	17	13
<b>90-6253</b>	<b>PARTS PACK, STRUT MOUNT</b>	<b>1</b>		
70-0503001800	1/2" X 3" GR 8 HEX BOLT	2	16	12
73-05000034	1/2" SAE GR 8 FLAT WASHER	4		
72-050100816	1/2" USS GR 8 STOVER NUT	2		

Box 4 of 4-PN 51494-4

922501	ES9000 SHOCK, FRONT	2
927500	ES9000 SHOCK, REAR	2

### Optional Equipment Available from your PRO COMP Distributor!

TRACTION BARS	PN 71000
SKID PLATE	PN 51190
PRO RUNNER STYLE LIGHT BAR	PN 14000 (BLACK), 14000G (GREY)
HOOP STYLE LIGHT BAR	PN 21400 (BLACK), 21400G (GREY)

**ALSO, CHECK OUT OUR OUTSTANDING SELECTION OF PRO COMP TIRES TO COMPLIMENT YOUR NEW INSTALLATION!**

### Special Equipment

A special removal tool is required for safe removal and installation of the torsion adjuster arms. This special puller can be purchased from your local GM dealer (Tool #J36202) or from the Kent Moore Tool Group in Roseville, MI. (800) 345-2233 or (313) 774-9500 (Part #J22517-C). You may be able to rent one of these at your local parts store. Please refer to your GM service manual for more information.

A welding machine and someone with welding experience is required for a small portion of this installation.

### Warning!

**Be extremely careful when unloading or loading the torsion bars on your vehicle. There is a tremendous amount of stored energy! Keep your hands and body clear of the adjuster arm assembly and puller tool in case anything slips or breaks!**

## Introduction:

- ◆ **This installation requires a professional mechanic!**
- ◆ We recommend that you have access to a GM service manual for your vehicle to assist in the disassembly and reassembly of your vehicle. It contains a wealth of detailed information.
- ◆ Prior to installation, carefully inspect the vehicle's steering and driveline systems paying close attention to the tie rod ends, ball joints, wheel bearing preload, pitman and idler arm. Additionally, check steering-to-frame and suspension-to-frame attaching points for stress cracks. The overall vehicle must be in excellent working condition. Repair or replace all worn or damaged parts!
- ◆ Read the instructions carefully and study the illustrations before attempting installation! You may save yourself a lot of extra work.
- ◆ Check the parts and hardware against the parts list to assure that your kit is complete. Separating parts according to the areas where they will be used and placing the hardware with the brackets before you begin will save installation time.
- ◆ Check the special equipment list and ensure the availability of these tools.
- ◆ Secure and properly block vehicle prior to beginning installation.
- ◆ ***ALWAYS*** wear safety glasses when using power tools or working under the vehicle!
- ◆ Use caution when cutting is required under the vehicle. The factory undercoating is flammable. Take appropriate precautions. Have a fire extinguisher close at hand.
- ◆ Foot pound torque readings are listed on the Torque Specifications chart at the end of the instructions. These are to be used unless specifically directed otherwise. Apply Loctite® retaining compound where specified.
- ◆ *Please note that while every effort is made to ensure that the installation of your Pro Comp lift kit is a positive experience, variations in construction and assembly in the vehicle manufacturing process will virtually ensure that some parts may seem difficult to install. Additionally, the current trend in manufacturing of vehicles results in a frame that is highly flexible and may shift slightly on disassembly prior to installation. The use of pry bars and tapered punches for alignment is considered normal and usually does not indicate a faulty product. However, if you are uncertain about some aspect of the installation process, please feel free to call our tech support department at the number listed on the cover page. We do not recommend that you modify the Pro Comp parts in any way as this will void any warranty expressed or implied by the Pro Comp Suspension company.*

## Please Note:

- ⇒ Front end and head light realignment is necessary!
- ⇒ Speedometer and ABS recalibration will be necessary if larger tires (10% more than stock diameter) are installed
- ⇒ This suspension system utilizes the stock torsion bars which normally afford the best ride quality. If, after kit is installed, ride or handling seems too "soft", heavier Gross Vehicle Weight Rating (GVWR) bars can be installed. GM offers various bars for up to 10,000 lbs. GVWR.
- ⇒ Due to differences in manufacturing, dimensions and inflated measurements, tire and wheel combinations should be test fit prior to installation. Tire and wheel choice is crucial in assuring proper fit, performance, and the safety of your Pro Comp equipped vehicle. For this application, we recommend a wheel not to exceed 8" in width with a minimum backspacing of 4" must be used, additionally, a quality tire of radial design, not exceeding 35" tall X 12.5" wide is also recommended. Please note that the use of a 35" X 12.5" tire may require fender modification. Violation of these recommendations will not be endorsed as acceptable by Pro Comp Suspension and will void any and all warranties either written or implied.
- ⇒ **IT IS ADVISABLE THAT YOU HAVE HELP AVAILABLE WHEN INSTALLING THIS KIT. SOME COMPONENTS ARE HEAVY AND AWKWARD. AN ADDITIONAL SET OF HANDS IS GOOD INSURANCE AGAINST INJURY!**

# Front Installation:

1. Ensure that your work space is of adequate size and the work surface is level. Place the vehicle in neutral. Place your floor jack under the front cross member and raise vehicle. Place jack stands under the frame rails behind the front wheel wells and lower the frame onto the stands. Remove the jack and place the vehicle back in gear, set the emergency brake, and place blocks both in front and behind the rear wheels.
2. Remove any factory skid plates or debris shields.
3. Remove the wheels and tires.

---

### **IMPORTANT!**

Mark both torsion bars (i.e., left side, right side, and front) to ensure they are returned to their original location and orientation. They must be reinstalled exactly as removed!

---

4. See **Illustration 1** for reference. Measure the adjusting screw depth on each torsion bar and record this dimension for later use on reassembly. Remove the torsion bar adjusting screws. Apply a small amount of lubrication grease to the puller threads (See *Special Equipment note on page 3*) and the puller shaft-to-adjuster arm contact point. Load the puller on one of the torsion adjuster arms until the adjuster nut can be safely removed from the cross member. Release the puller to unload the torsion bar. Repeat this procedure on the opposite side. With the bars unloaded slide each forward into the lower control arm until its adjuster arm falls free. More detailed instructions on this procedure are in your GM service manual.

**Note:** If the bars seem stuck, make sure the adjuster is loose and then use a hammer and punch through the hole at the rear of the cross member to dislodge them.

5. Remove the torsion bar cross member by removing the three bolts per rail on each side of the vehicle. It may be necessary that you raise the exhaust slightly to gain clearance for removal of the cross member.
6. With this cross member out of the way, the torsion bars can now be pulled from the lower control arms and removed. Save this hardware for reuse on reassembly.
7. If your vehicle has ABS, disconnect the ABS wiring. Secure the wiring out of the way in a safe location.
8. Remove the brake calipers and secure them out of the way.  
**Important:** Be very careful with the brake lines! Do not damage them!!
9. Remove the OE shock absorbers and properly dispose of them.
10. Remove the sway bar links from the sway bar and lower A-arms.
11. Remove the six retaining bolts from each half shaft at the differential and separate the two components.

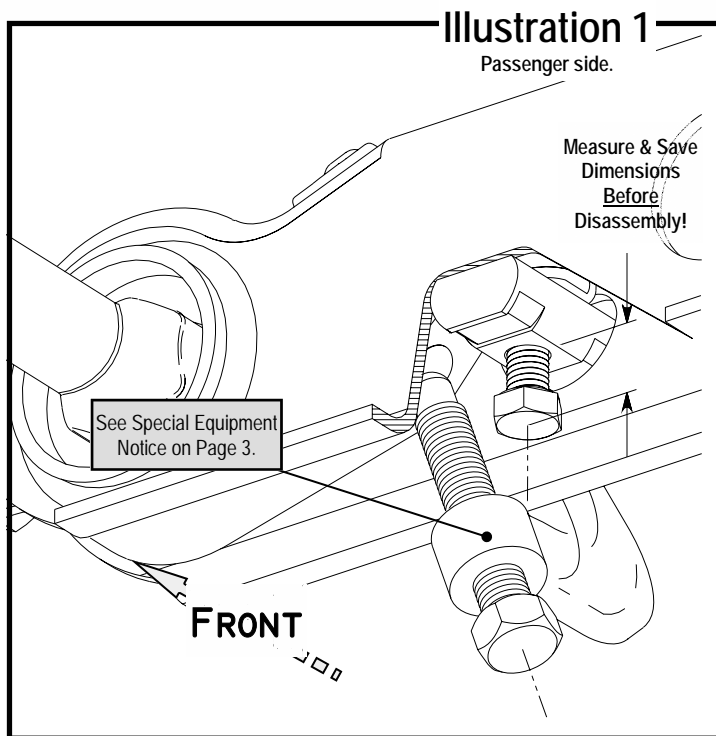

12. Remove the tie rod ends from the spindle.  
*Note: There are special tools available to minimize the damage to the tie rod protective boots and threads. Refer to your factory service manual for tool part numbers and additional information.*

13. Remove the upper and lower A-arm pivot nuts. Keep this hardware for reuse.  
14. Use your floor jack to support each A-arm assembly, carefully remove the A-arm pivot bolts and remove each A-arm assembly from the vehicle. Place these assemblies clear of the work area.

*Note: **Be very careful with this procedure!** The A-arm assembly is heavy and very flexible. Be very careful with your fingers!*

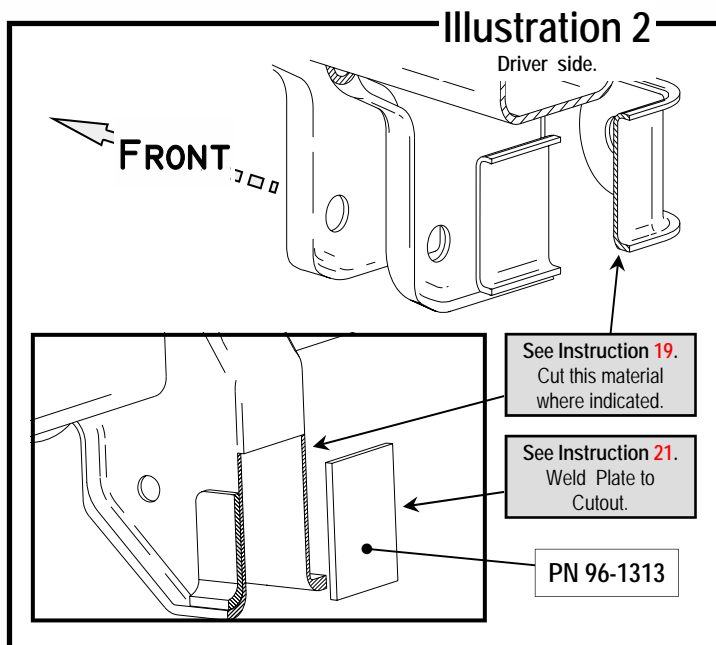

15. Disconnect the differential vent line and electrical connections and secure them out of the way.  
16. Disconnect the front drive shaft from the front differential and secure it out of the way.  
17. Remove the center link from the pitman arm and idler arm. Again, be careful not to damage the boots.  
18. Remove the differential mounting bolts from the passenger side. Keep this hardware for re-use.  
19. On the driver side at the lower differential mount, remove the mounting hardware. Using a sawzall or other suitable cutting tool, cut off the driver side rear wrap around bracket, as shown in **Illustration 2**. This will allow the differential to drop straight down. Retain this hardware for reuse.  
20. Support the differential with your floor jack and remove the remaining bolt at the top of the differential on the driver side. Carefully lower the differential from the vehicle.  
21. Cut the rear of the A-arm pocket to allow the weld in plate (**PN 96-1313**) to be welded flush with the upper portion of the pocket and weld in **PN 96-1313**.  
22. If there is a steering damper installed, remove it.  
23. On both sides of the frame near the upper control arm mounts, remove the stock rubber bump stops from their mounts and discard them.

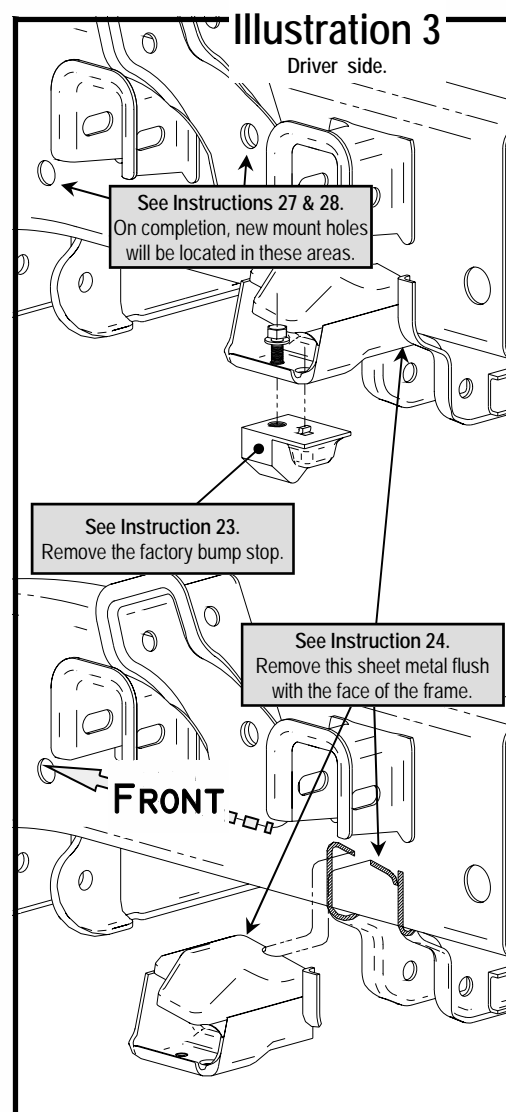

**CAUTION:**

The factory undercoating is very flammable! Use caution while using the cutting torch. Have an assistant with ready access to a fire extinguisher close at hand!

24. Using a cutting torch or sawz-all, carefully cut the bump stop mounts from the frame and using a disk grinder, smooth the area flush with the frame. See **Illustration 3 & 4**. Clean the area and paint and undercoat any exposed metal.

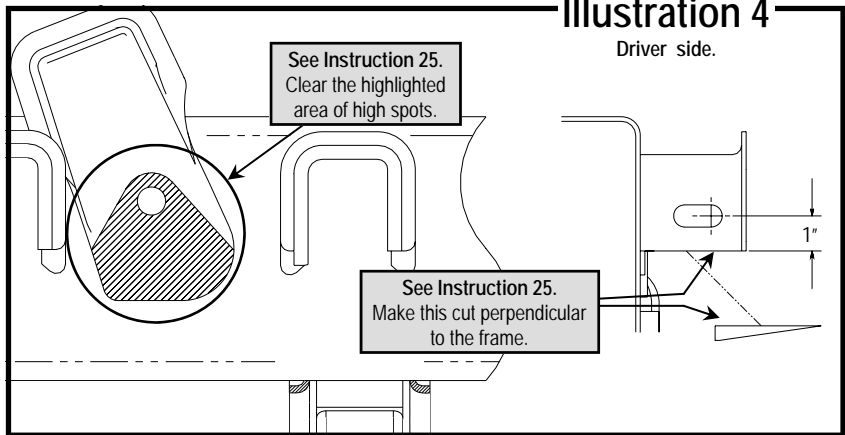

**Note:** Don't get carried away here. Remove only enough material to make the surface flat.

25. As seen in **Illustration 4**, material must be removed from the bottoms of the upper A-arm brackets and in the area indicated on the shock bracket. Remove only enough material for the new A-arm drops to fit properly.
26. Remove the sway bar from the frame. Flip it over and re-install it with its original mounts. Snug the hardware enough to keep the sway bar clear of the work area.
27. Temporarily install the upper A-arm drops (**PN 90-1498 (Driver) & 90-1499 (Passenger)**) into the OE A-arm mounts using the OE mount bolts and then clamp them against the frame. Make sure the bracket is parallel to the frame. If it is not parallel, grind material away until it is. Drill the center and front mount holes completely through the frame with a 1/2" drill using the drops as drill guides. See **Illustration 5**.

**Note:** The rear hole is an existing hole about 1" in diameter.

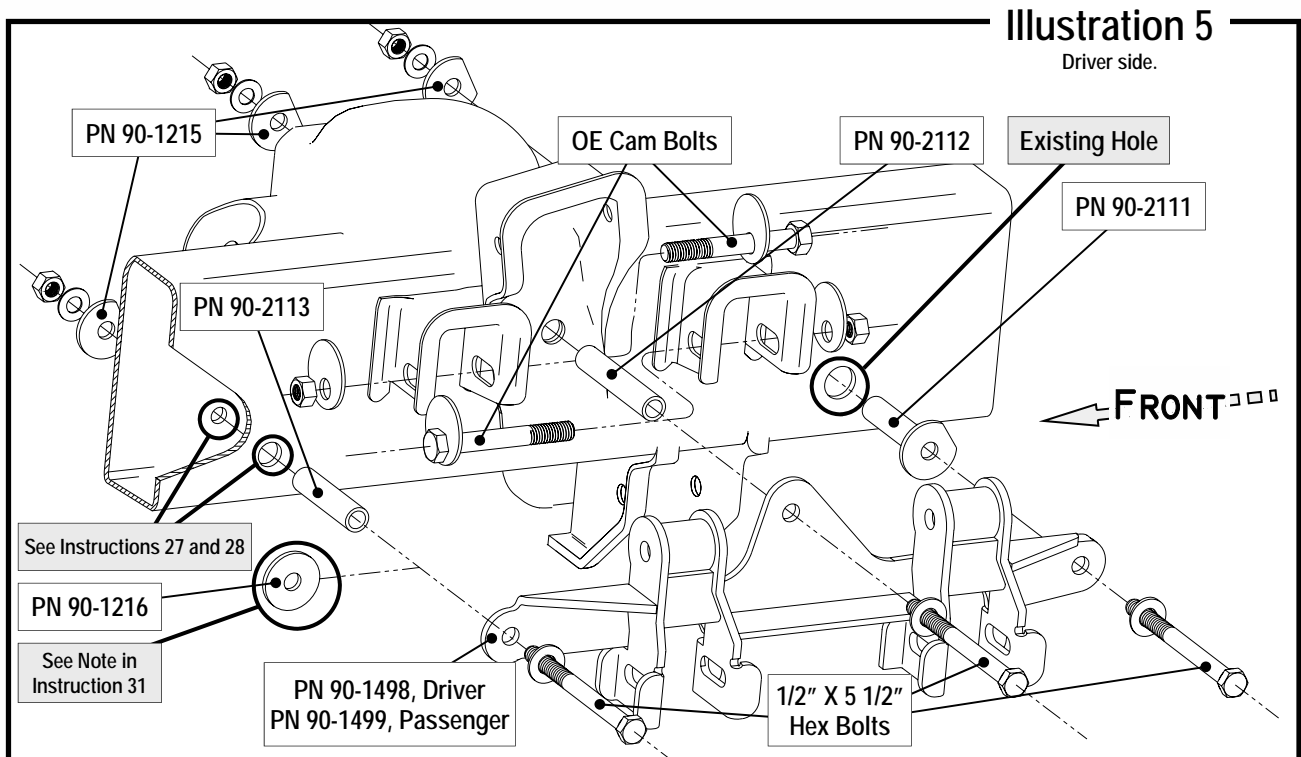

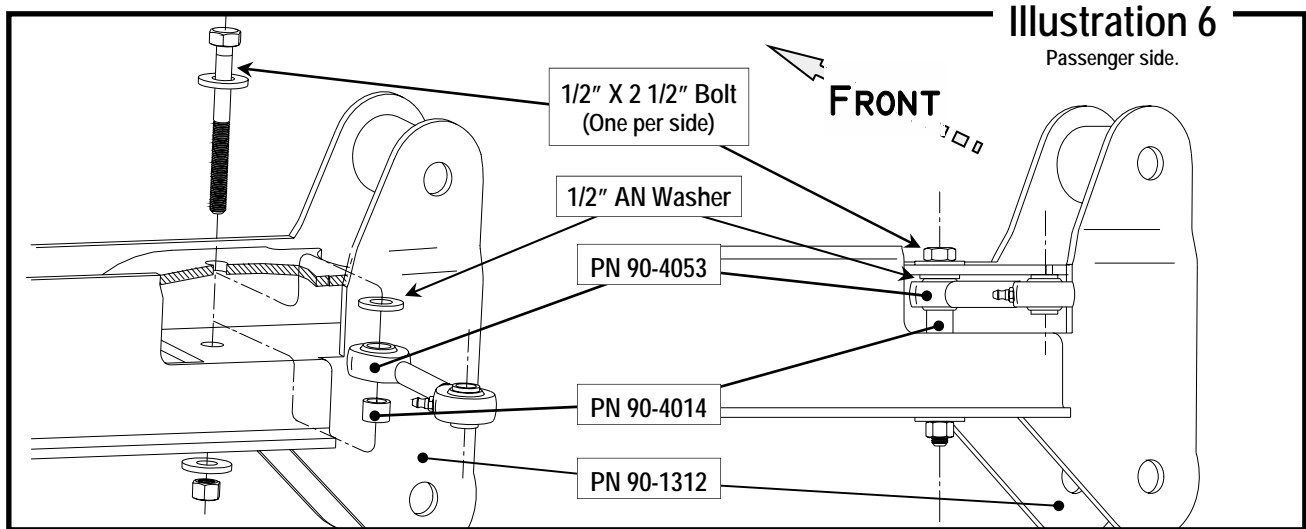

28. After the holes have been drilled, remove the drops and re-drill the **OUTER HOLES ONLY** to 3/4".
29. When you are satisfied with the fit of the upper drops you should clean, paint and undercoat the exposed metal areas.
30. Install the sleeves (PN 90-2111 (with flange), 90-2112 (3/4" X 1/2" X 3.940"), & 90-9113 (3/4" X 1/2" X 3.440")) from hardware pack 90-6083 through the 3/4" holes into position as shown in **Illustration 5**. PN 90-2111 will be installed into the rear hole. The flat portion of the welded flange is rotated to clear the frame.
31. Re-install the drops using the OE A-arm bolts through the upper slotted holes and the 1/2" X 5 1/2" bolts supplied through the adapter, sleeves, and frame. Install the provided load washers (PN 90-1215) from hardware pack 90-6083, flat washers and nuts from hardware pack 90-6078 to the back of the frame to complete the installation. Torque the through bolts to spec first, then torque the OE bolts to spec.

*Note: On some installations, there may be excess space between the adapter and the front hole in the frame. A special load washer is supplied (PN 90-1216) to fill in this gap.*

---

**Note:** On steps 32 thru 36, it is *extremely important* that you follow the instructions and illustrations exactly! If you do anything differently, do not expect your vehicle to be stable while driving it!

---

32. Using **Illustration 8** for reference, drop one of the 1/2" X 4 1/2" bolts with one of the 1/2" AN washers through the center link drop. This must be done now. The bolts cannot be installed after the drop is mounted.

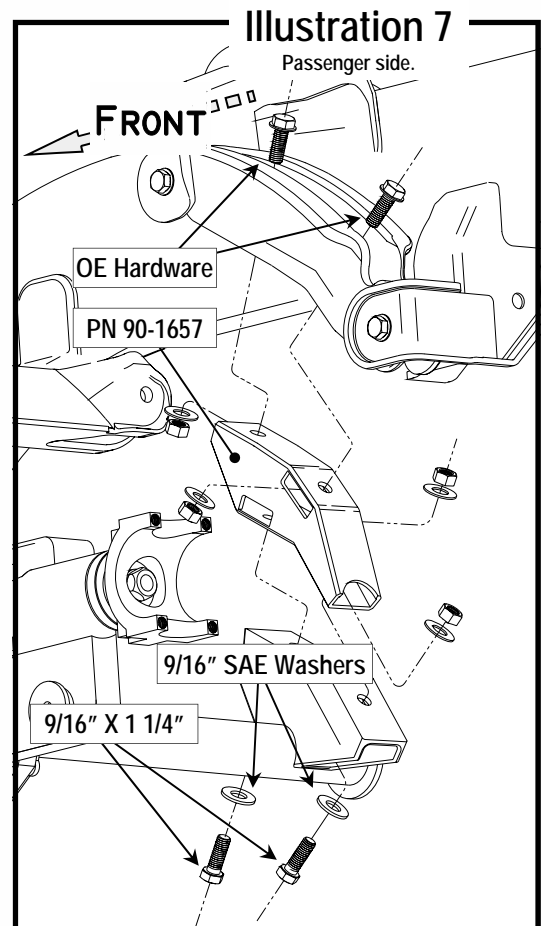



# Illustration 8

View From Passenger, Rear.

FRONT

**See Instruction 33**  
The drop link is marked  
for proper installation.  
This factory hole is  
oriented to the top,  
front of the vehicle.

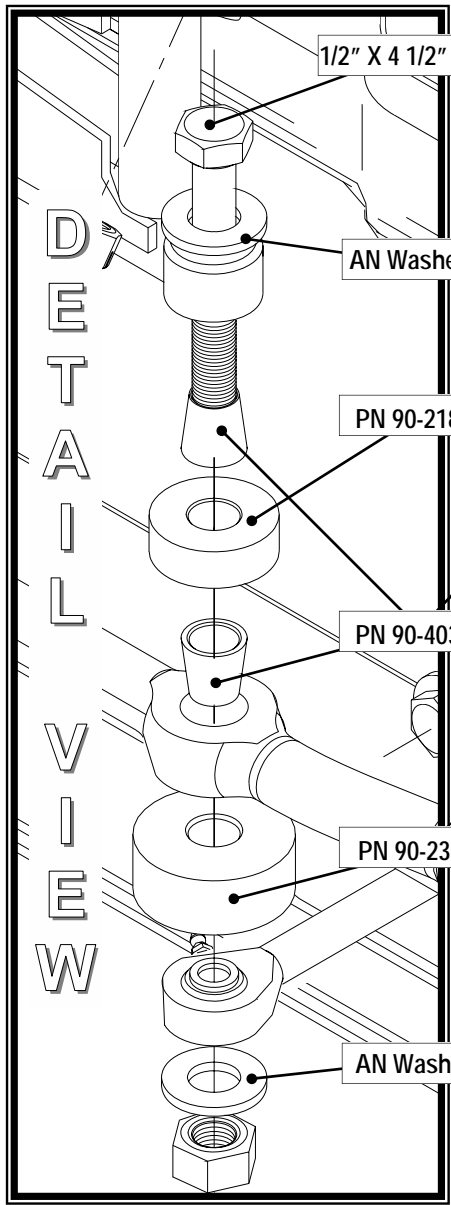

PN 90-2305

OEM Hardware  
(Both Sides)

**See Instruction 36**  
*Make sure these  
spacers are installed  
properly!!*  
1/2" spacer on top.  
1" spacer on bottom.

PN 90-1312

33. Loosely install the center link drop (PN 90-2305) onto the OE idler arm and pitman arm as shown in **Illustration 8**.

*Note: One web has a hole in it that must be oriented to the top, front, drivers side when complete.*

34. Install the rod end guides (PN 90-4053) to the front cross member (PN 90-1312) as shown in **Illustration 6**. Use the supplied 1/2" X 2 1/2" bolts, spacers (PN 90-2014), washers and nuts from hardware packs 90-6229 and 90-6231. Tighten these bolts to spec.

35. Install the front cross member assembly to the OE lower A-arm mount using the OE bolts previously removed. The rod end guides are oriented to the rear of the vehicle. See **Illustration 8**.

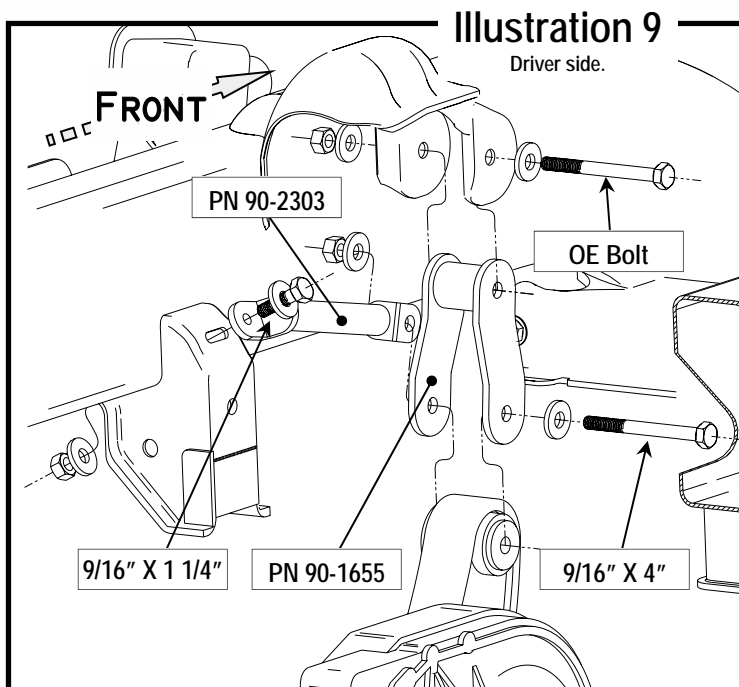

36. Slide one of the reducer cones (90-4036 (small end up)), the 1/2" long spacer (90-2308), and another reducer cone (90-4036 (small end down)) onto the bolt. Pay particular attention to the cone orientation, they must fit inside the tapered ends on the center link. Slide the center link over the bolt, install the 1" long spacer (90-2309) and then run the bolt through the steering link support. Install another AN washer and the stover nut. Leave this side loose until the other side is assembled in exactly the same order. Repeat these steps on the remaining side and torque these fasteners to spec.

37. Install the passenger side differential drop (PN 90-1657) to the vehicle frame using the OE fasteners. Use **Illustration 7** as a guide.

*Note: It may be easier to install this adapter with the OE bracket removed.*

38. Install the driver side differential drop (PN 90-1655) to the vehicle frame using the OE fastener. Use **Illustration 9** as a guide.

39. Again, using **Illustration 9** as a guide, use your floor jack and carefully raise the differential up into the differential drop mount at the driver side. Install the 9/16" X 4" bolt from hardware pack 90-6226 through the differential drop and differential. Do not install the nut and washer at this time.

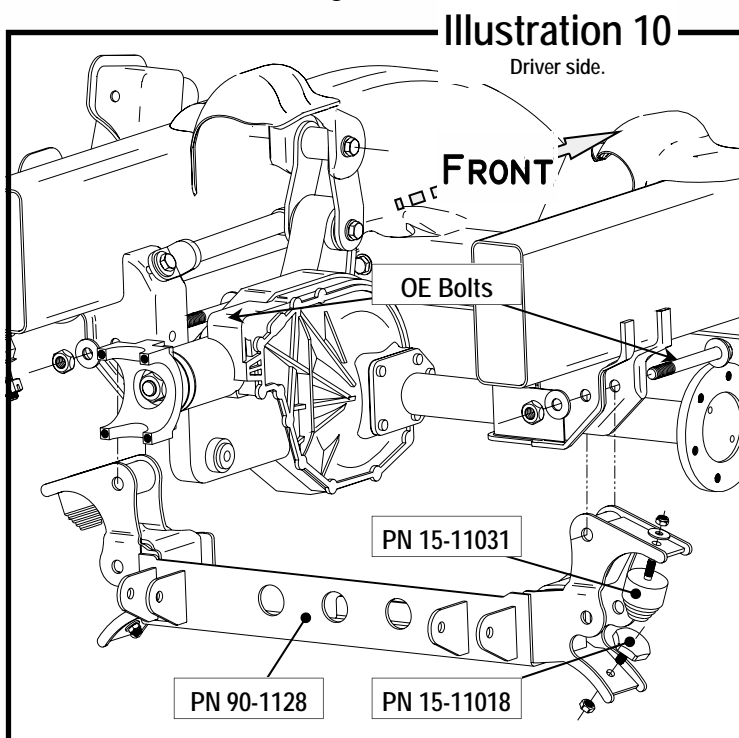

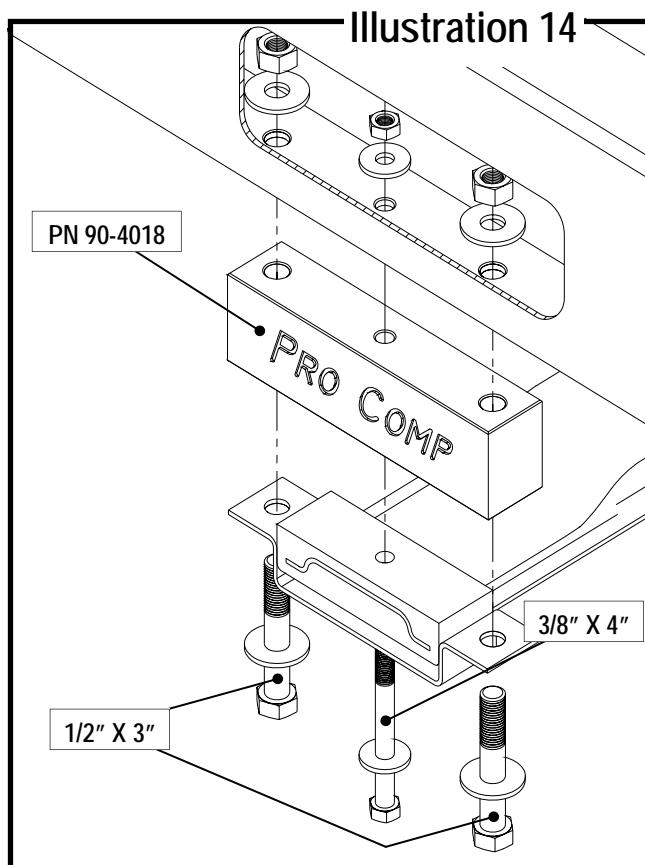
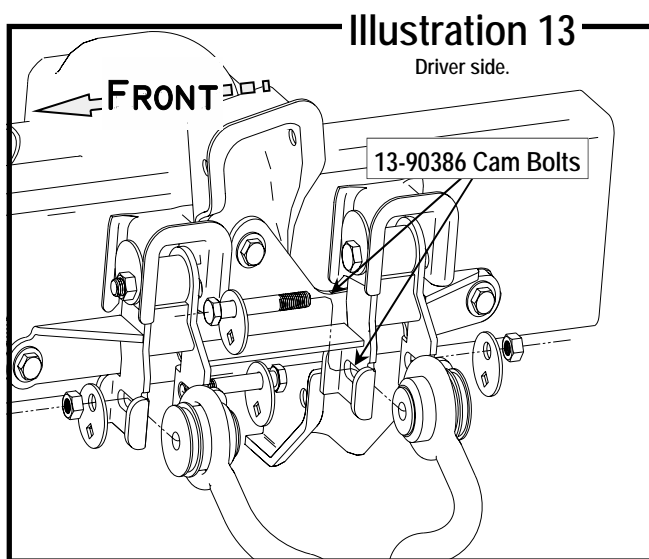
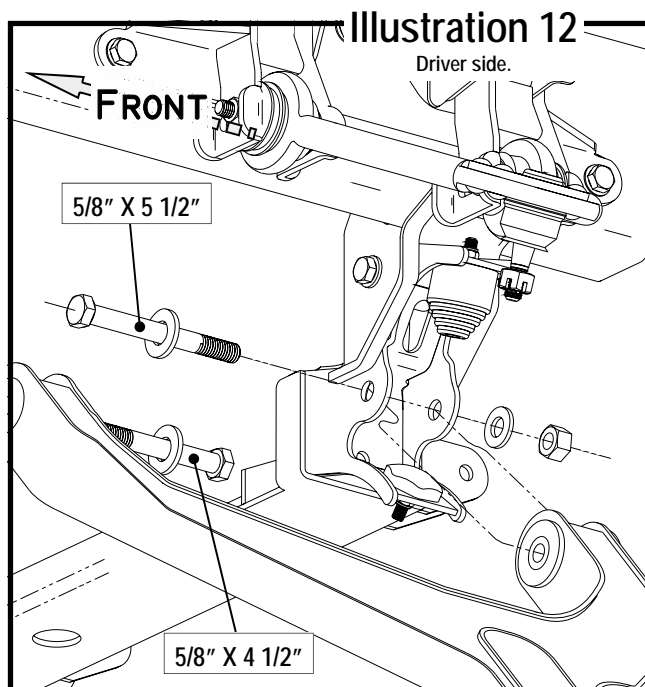
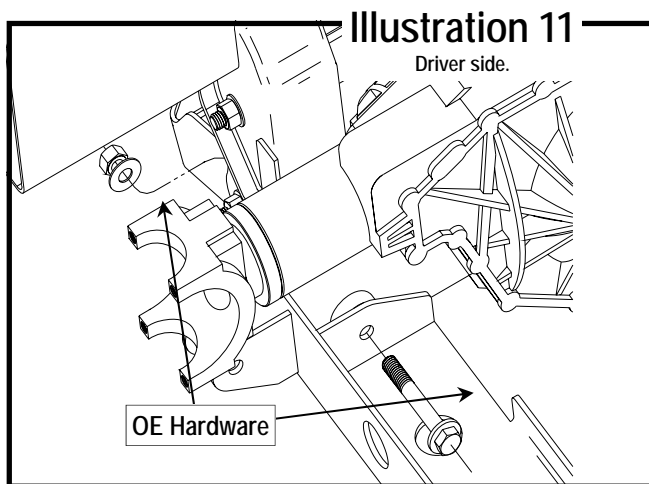

40. Install the torque tube (PN 90-2303) onto the **9/16" X 4"** bolt as shown in **Illustration 9**, and install the washer and nut. Tighten this hardware just enough to allow movement until the next step is complete.
41. Insert the **9/16" X 1 1/4"** bolts through the passenger axle flange and through the passenger adapter. Install the flat washer and nut as shown in **Illustration 7** and snug up the hardware.
42. Install the rear cross member (PN 90-1128) into the OE lower A-arm mounts using the OE mount bolts. Orient the bolts from the inside of the A-arm pocket to the outside, (the threads pointing away from the front axle). See **Illustration 10**.
43. Install the OE bolt to the lower differential mount. Install the bolt with the threads oriented to the outside of the cross member as shown in **Illustration 11**.

44. Re-install the differential vent tube and electrical connections.
45. Center the differential in the chassis by measuring from the center of the CV mount flange to the lower control arm mount hole on the driver side of the vehicle. Repeat the procedure on the passenger side of the vehicle using the same reference points and adjust the differential location until both dimensions are equal. At this point, while maintaining the differential alignment, rotate the torque tube up until it is aligned with a pre-existing slot at the rear of the upper A-arm mount. Insert the **9/16" X 1 1/4"** bolt from hardware pack **90-6226** through the strut and frame and torque all hardware to specs. Orient the fasteners as shown in **Illustration 9**.

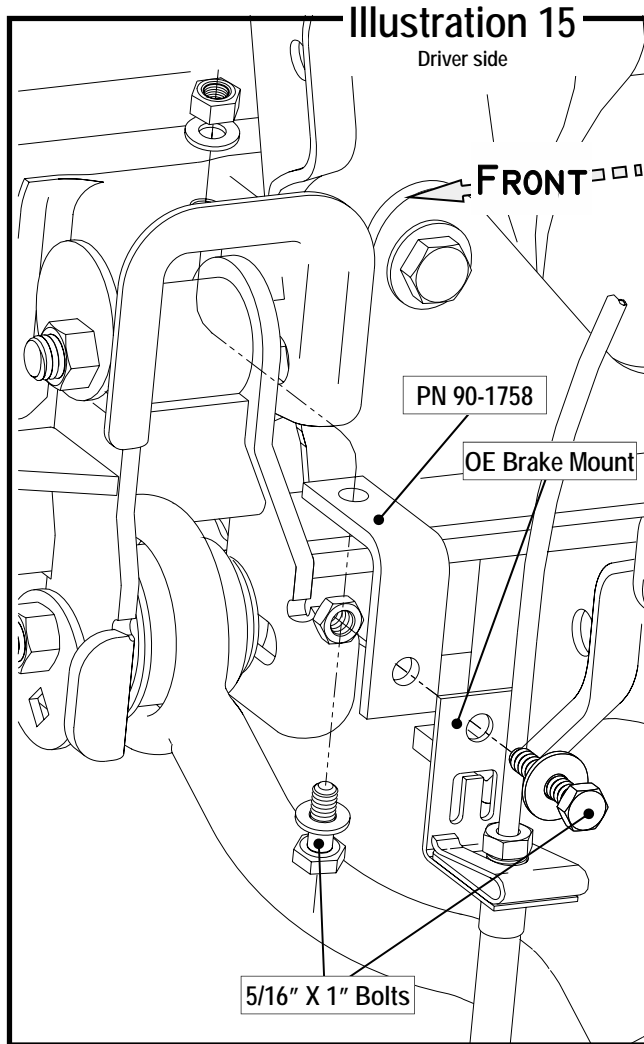

46. Re-install the A-arm assemblies by reversing the order of disassembly. Use your floor jack to raise the A-arm assembly into position and on the lower A-arms use the **5/8" X 4 1/2"** bolts at the front mount and the **5/8" X 5 1/2"** bolts at the rear mount. These bolts are in hardware pack **90-6228**. See **Illustration 12**.

*Note: Make sure the sway bar is positioned between the upper and lower A-arms, and above the tie rods before proceeding to the next step.*

**IMPORTANT:**  
When reinstalling the A-arm assemblies, do not torque the cam bolts and pivot bolts until the installation is almost complete and the vehicle is resting on the ground. This will allow the bushings to be in a "neutral" position when the final torque is applied and will help insure against premature bushing failure.

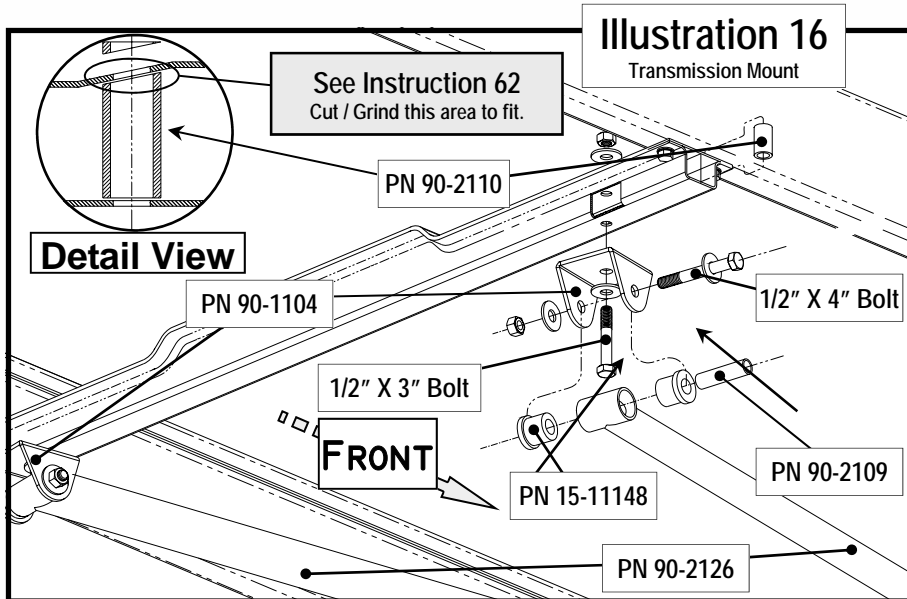

47. Install the bump stop (PN **15-11031**) and droop stop (PN **15-11018**) to the ends of the cross member as shown in **Illustration 10**, and torque the fasteners to 30 ft. lbs.

48. Install the upper A-arms using the cam bolts (**PN 13-90386**) provided in hardware pack **90-6082**. Orient the bolts the same as the lower control arms, all threads point away from the CV boot. See **Illustration 13**.
49. Reattach the CV joint to the drive flange using the OE bolts. Use Loctite® on the bolts and torque them to 60 ft. lbs.
50. Re-install your brake calipers and ABS wiring if your vehicle has ABS.
51. Use the fasteners from hardware pack **90-6245** to install the relocation brackets (**PN 90-1758**) between the OE upper A-arm bracket and the new A-arm drops as shown in **Illustration 15**.
52. Re-route the brake lines by first removing them from the stock location and bolting them to the newly installed brackets as shown in **Illustration 15**. This will require that you **CAREFULLY** re-route the OE brake lines to the new location. On completion of the installation, visually inspect to ensure that the brake lines are not rubbing on any other part of the vehicle. This includes an inspection above the frame as well.
53. Re-install the tie rod ends to the steering knuckles.
54. Install the front sway bar drop links in hardware pack **90-6100**. Use the instructions enclosed with the hardware pack for installation.
55. Re-install the front driveshaft. If it does not clear the exhaust crossover pipe, reroute a new section of pipe either above or below the shaft. If necessary, the vehicle can be driven with the front shaft completely removed. Torque the drive shaft to factory specifications.  
*Note: The drive shaft needs to be reversed on 1994 and 1995 models equipped with front drive shafts utilizing U-joints at both ends.*
56. Insert the torsion bars into the lower control arms.
57. Flip the torsion bar brackets so they will mount under the frame and install the new aluminum torsion bar drops (**PN 90-4018**) between these brackets and the frame as shown in **Illustration 14**.
58. Slide one of the torsion bars to the rear through the torsion cross member and through the torsion adjuster. Use your puller (Special Tools on page 3) to reload the torsion bars and insert the adjuster screw to the same depth as recorded on disassembly. See Instruction 4.
59. Repeat this procedure for the remaining side.
60. Assemble the urethane bushings and sleeves to the compression struts (**PN 90-2126**) as shown in **Illustration 16**.
61. The struts have one end welded at a slight angle. This angled end is mounted to the rear cross member with the remainder of the bar angled to the outside of the vehicle.
62. The rear mounts are located on the transmission cross member and held in place with the **1/2" X 3"** hardware provided in hardware pack **90-6253**. An anti crush sleeve (**PN 90-2110**) is provided and is inserted through the end of the cross member and aligned with the mount holes as seen in **Illustration 16**. Depending on what transmission you have in your vehicle, some cross members have a slight angle at the top that will require you to grind material from the sleeve for an adequate fit. A detail view of this modification is shown in the illustration at the top left corner.
63. Check all fasteners and hardware for proper installation and proper fastener torque but do NOT torque the A-arm hardware yet!

64. Thoroughly bleed all air from the brake system following the procedures outlined in your GM service manual.
65. Re-install your wheels and tires.
66. Lower the vehicle to the ground.
67. At this point, tighten the lower A-arm pivot bolts to spec. Set the upper cam bolts to a neutral position and tighten them to specs. The purpose of this is to allow you to get to a front end shop for realignment ONLY!! Do not assume that the alignment is “close enough”!!

## Rear Installation:

1. Raise the rear of the truck enough for the tires to clear the ground and use jack stands on the frame to support the truck.
2. Remove the rear tires and wheels.
3. Carefully remove the OEM shock absorbers. It may be necessary to raise the differential housing slightly to facilitate their removal.
4. One side at a time, support the differential housing on the side being modified. Remove the “U” bolts from that axle end and discard them. Loosen the other side a couple of turns.

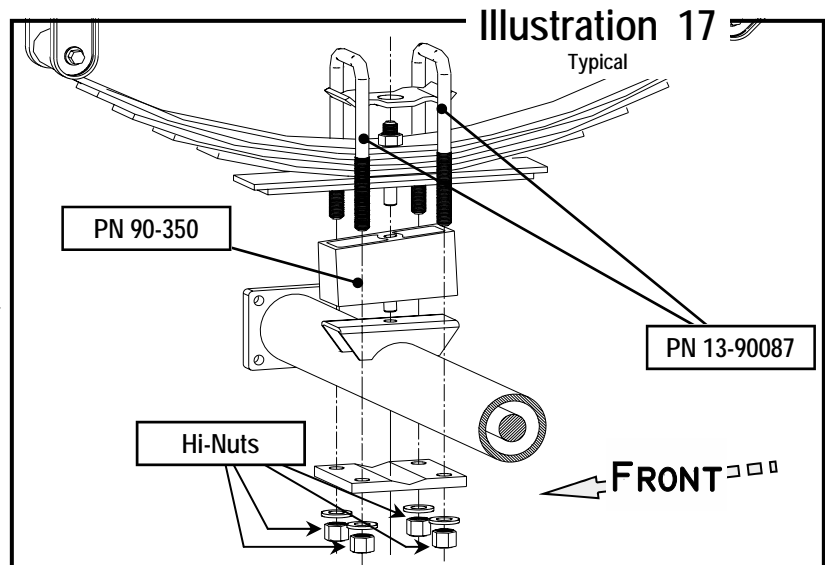

5. Install the new riser block (**PN 90-350**), short end to the front, to the mount pad on the axle housing and raise the axle housing until the riser block hole fits around the new leaf spring center bolt.
6. Install the new “U” bolts over the leaf spring assembly and using the new washers and nuts supplied along with the existing spring plates, torque the U-bolt nuts to 105 ft./lbs. See **Illustration 19**.
6. Repeat these steps on the other side of the vehicle.
7. Before installing your new Pro Comp shock absorbers, it is necessary that you check for adequate clearance. Temporarily install your Pro Comp shocks, rod end up, into the shock mounts. Carefully check for clearance issues. If there are areas that come in contact with or are very close to your new shocks, carefully remove sufficient material to ensure trouble free operation. Pay particular attention to the area around the lower shock mount. When all clearance issues have been resolved, install your new Pro Comp shock absorbers and recheck all fasteners for proper installation and torque.
8. Install your wheels and tires and lower the vehicle to the ground.
9. After installation is complete, double check that all nuts and bolts are tight. Refer to the chart at the end of this document for torque specifications. (Do not retighten nuts and bolts where Loctite® was used).

## Bolt Torque and ID

### Decimal System

### Metric System

All Torques in Ft. Lbs.

Bolt Size	Grade 5	Grade 8	Bolt Size	Class 9.8	Class 10.9	Class 12.9
5/16	15	20	M6	5	9	12
3/8	30	45	M8	18	23	27
7/16	45	60	M10	32	45	50
1/2	65	90	M12	55	75	90
9/16	95	130	M14	85	120	145
5/8	135	175	M16	130	165	210
3/4	185	280	M18	170	240	290

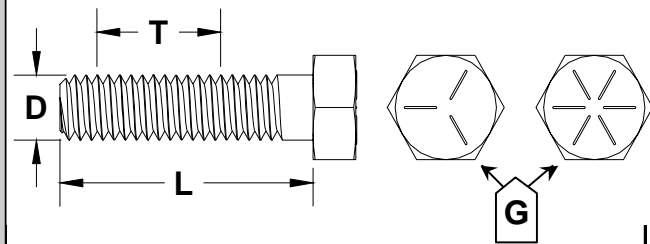

1/2-13x1.75 HHCS



Grade 5    Grade 8  
(No. of Marks + 2)

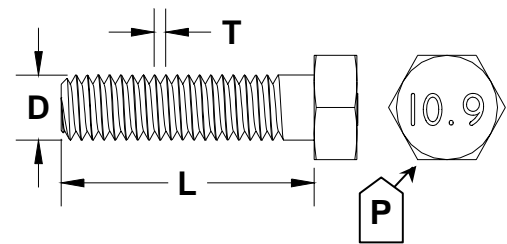

M12-1.25x50 HHCS



G = Grade (Bolt Strength)  
D = Nominal Diameter (Inches)  
T = Thread Count (Threads per Inch)  
L = Length (Inches)  
X = Description (Hex Head Cap Screw)

P = Property Class (Bolt Strength)  
D = Nominal Diameter (Millimeters)  
T = Thread Pitch (Thread Width, mm)  
L = Length (Millimeters)  
X = Description (Hex Head Cap Screw)

**Notice to Owner operator, Dealer and Installer:**

Vehicles that have been enhanced for off-road performance often have unique handling characteristics due to the higher center of gravity and larger tires. This vehicle may handle, react and stop differently than many passenger cars or unmodified vehicles, both on and off-road. You must drive your vehicle safely! Extreme care should always be taken to prevent vehicle rollover or loss of control, which can result in serious injury or even death. Always avoid sudden sharp turns or abrupt maneuvers and allow more time and distance for braking! Pro Comp reminds you to fasten your seat belts at all times and reduce speed! We will gladly answer any questions concerning the design, function, maintenance and correct use of our products.

**Please make sure your Dealer/Installer explains and delivers all warning notices, warranty forms and instruction sheets included with Pro Comp product.**

Application listings in this catalog have been carefully fit checked for each model and year denoted. However, Pro Comp reserves the right to update as necessary, without notice, and will not be held responsible for misprints, changes or variations made by vehicle manufacturers. Please call when in question regarding new model year, vehicles not listed by specific body or chassis styles or vehicles not originally distributed in the USA.

**Please note that certain mechanical aspects of any suspension lift product may accelerate ordinary wear of original equipment components.** Further, installation of certain Pro Comp products may void the vehicle's factory warranty as it pertains to certain covered parts; it is the consumer's responsibility to check with their local dealer for warranty coverage before installation of the lift.

**Warranty and Return policy:**

Pro Comp warranties its full line of products to be free from defects in workmanship and materials. Pro Comp's obligation under this warranty is limited to repair or replacement, at Pro Comp's option, of the defective product. Any and all costs of removal, installation, freight or incidental or consequential damages are expressly excluded from this warranty. Pro Comp is not responsible for damages and / or warranty of other vehicle parts related or non-related to the installation of Pro Comp product. A consumer who makes the decision to modify his vehicle with aftermarket components of any kind will assume all risk and responsibility for potential damages incurred as a result of their chosen modifications. Warranty coverage does not include consumer opinions regarding ride comfort, fitment and design. Warranty claims can be made directly with Pro Comp or at any factory authorized Pro Comp dealer.

**IMPORTANT!** To validate the warranty on this purchase please be sure to mail in the warranty card.

**Claims not covered under warranty-**

- Parts subject to normal wear, this includes bushings, bump stops, ball joints, tie rod ends and heim joints
  - Discontinued products at Pro Comp's discretion
- Bent or dented product
- Finish after 90 days
- Leaf or coil springs used without proper bump stops
- Light bulbs
- Products with evident damage caused by abrasion or contact with other items
- Damage caused as a result of not following recommendations or requirements called out in the installation manuals
- Products used in applications other than listed in Pro Comp's catalog
- Components or accessories used in conjunction with other manufacturer's systems
- Tire & Wheel Warranty as per Pro Competition Tire Company policy
- Warranty claims without "Proof of Purchase"
- Pro Comp Pro Runner coil over shocks are considered a serviceable shock with a one-year warranty against leakage only. Rebuild service and replacement parts will be available and sold separately by Pro Comp. Contact Pro Comp for specific service charges.
- Pro Comp accepts no responsibility for any altered product, improper installation, lack of or improper maintenance, or improper use of our products.

E-Mail: [tech@explorerprocomp.com](mailto:tech@explorerprocomp.com)  
Website: [www.explorerprocomp.com](http://www.explorerprocomp.com)  
Fax: (619) 216-1474  
Ph: (619) 216-1444

<u>PLACE</u>
<u>WARRANTY REGISTRATION</u>
<u>NUMBER</u>
<u>HERE:</u> _____