

2360 Boswell Road
Chula Vista, CA 91914
Phone 619.216.1444
Fax 619.216.1474
E-Mail tech@explorerprocomp.com



PRO COMP SUSPENSION

Suspension Systems that Work!

**Part # 57095
Toyota Tacoma
4WD IFS
4" Suspension
System**

This document contains very important information that includes warranty information and instructions for resolving problems you may encounter. Please keep it in the vehicle as a permanent record.

PART# DESCRIPTION QUANTITY ILLUSTRATION#

NOTE: This instruction packet contains valuable warranty information and should be kept in the vehicle as a permanent record.

NOTE: Part #7213 extended brake lines are required to complete the installation of the 57095 kit and must be purchased separately.

NOTE: An instructional video is available for this suspension system. Contact Pro Comp customer service to obtain the video.

90-1328	Pass. Spindle Support Brkt.	1	25
90-1329	Drvr. Spindle Support Brkt.	1	25
90-1332	Front Crossmember	1	17-18
90-1354	Rear Crossmember	1	15
90-4014	Shock Spacer	2	26
90-4013	Spindle Spacer	2	24C-25
90-6141	Hardware Pack Containing:		
70-0754501800	3/4" x 4 1/2" USS Gd. 8 Hex Bolt	4	15-17
70-0628501500	5/8" x 8 1/2" USS Gd. 5 Hex Bolt	1	24
70-0622751500	5/8" x 2 3/4" USS Gd. 5 Hex Bolt	1	24
70-0568501500	9/16" x 8 1/2" USS Gd. 5 Hex Bolt	1	24
70-0561001500	9/16" x 1" USS Gd. 5 Hex Bolt	1	13
71-1409015008800	14mm x 90mm x 1.5 x 8.8	1	24
71-140251500880	14mm x 25mm x 1.5 x 8.8	1	16
73-06200030	5/8" SAE Flat Washer	4	24
73-05600034	9/16" SAE Hardened Flat Washer	4	13-24
73-05600036	9/16" Split - Lock Washer	2	16-24
72-07500100816	3/4" USS Stover Nut	4	19
72-06200100512	5/8" USS Nyloc Nut	2	24
72-05600100512	9/16" USS Nyloc Nut	2	13-24
90-6142	Hardware Pack Containing:		
70-0504501800	1/2" x 11" USS Gd. 8 Hex Bolt	2	18
70-050201500	1/2" x 2 1/2" USS Gd. 5 Hex Bolt	1	16
70-0372501500	3/8" x 1" USS Gd. 5 Hex Bolt	2	19
70-0311001800	5/16" x 1" USS Gd. 8 Hex Bolt	4	27
70-0311001808	5/16" x 1" USS Gd. 8 Button Head	1	21
73-05000030	1/2" SAE Flat Washer	2	16
73-04300030	7/16" SAE Flat Washer	6	26
73-03700030	3/8" SAE Flat Washer	8	14-19
73-03100034	5/16" SAE Hardened Flat Washer	8	27
72-05000100816	1/2" USS Stover Nut	2	18
72-05000100512	1/2" USS Nyloc Nut	1	16
72-04300200512	7/16" SAE Nyloc Nut	6	26
72-03700100512	3/8" USS Nyloc Nut	2	19
72-03100100816	5/16" USS Stover Nut	4	27

	Loctite Tube - Small, Red	1	
90-6146	Bracket Bag Containing:		
020100	U-Bolt	2	25
90-1083	ABS Wiring Extension	1	32
90-1336	Steering Box Support Bracket	1	16
90-1339	Sway Bar Drop Bracket (pass.)	1	27
90-1340	Sway Bar Drop Bracket (driver)	1	27
90-1344	Crossmember Support Bracket	1	13
90-1345	Locating Washer	8	15,17
90-1347	ABS Extension Bracket	1	29
90-2075	Sleeve .750" x .150" x .312"	2	18
90-2166	Spacer Diff. Mount	2	18
90-2169	Steering Yoke Extension	1 21	
90-6144	Hardware Pack Containing:		
70-0311751500	5/16" x 1 3/4" USS Gd. 5 Hex Bolt	1 29	
73-03100030	5/16" SAE Flat Washer	2	29
72-03100100512	5/16" USS Gd. 5 Nyloc Nut	1	29
90-6140	Power Steering Kit		
90-4029	Pressure Line	1	22
90-4030	Return Line	1	23
90-6145	Hardware Pack Containing:		
73-06200032	5/8"USS Flat Washer	4	24C
90-2167	Tool, Ball Joint	1	24C
90-6143	Hardware Pack Containing:		
70-0502252800	1/2" x 2 1/4" SAE Gd. 8 Hex Bolt	2	25
73-05000538	1/2" SAE Hardened A.N. Washer	4 25	
72-05000200816	1/2" SAE Gd. C Stover Nut	2	25
90-6139	Hardware Pack Containing:	1	25
13-22106	Set Screw, 3/8" - 16 x 1-1/2" Lg.	2	25
13-10016-B	Jam Nut, 3/8" - 16	2	25
13-30434-Z	Flat Washer, 5/16" A.N.	8	25
13-10566-Z	Top Lock Nut, 5/16" - 18	4	25

Box 2 of 2 PN 57095-2

90-1369	Skidplate	1	28
90-6149	Hardware Pack Containing:		
70-0371001500	Hex Bolt, 3/8" - 16 x 1" Lg.	4	28
73-03700536	Split Lock Washer, 3/8"	4	28

The following special tools will be required for the proper installation of this kit.

NOTE: The following parts are used in conjunction with this kit and must be ordered separately.

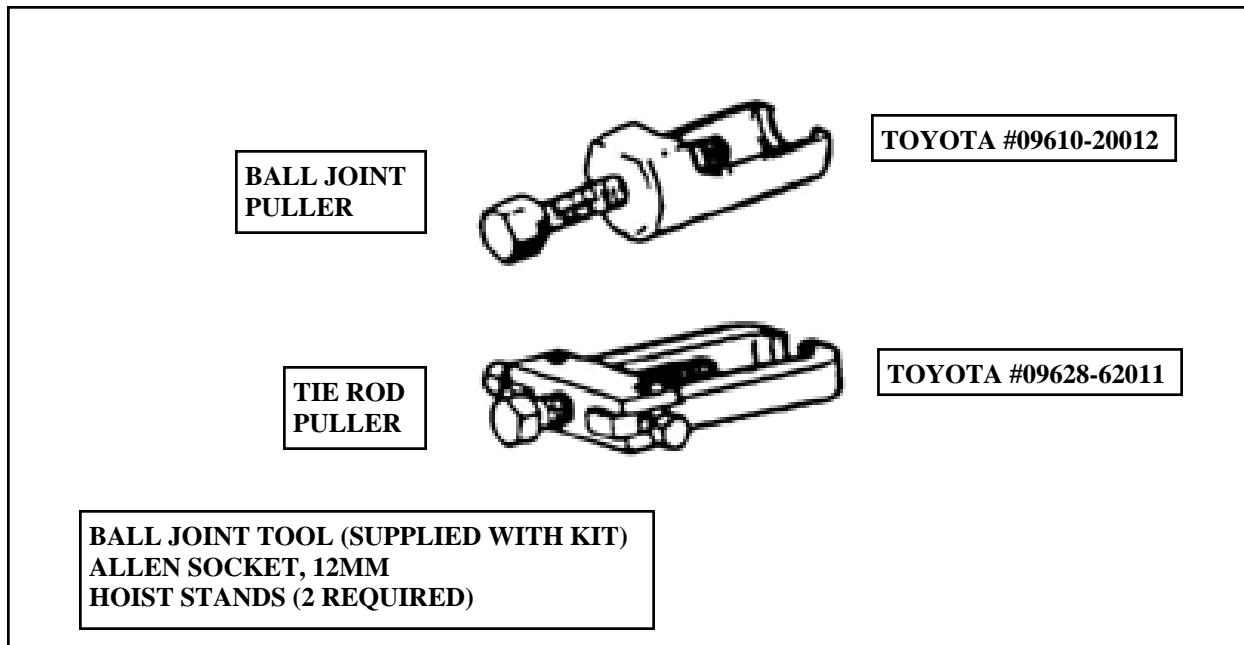

ITEM#	DESCRIPTION	QTY.
57589	Rear Block Kit	1
326006	ES3000 Shock Absorber (Rear)	2
618053	Front Strut	2
7213	Brake Line Kit	1

Pro Comp now offers a skid plate, traction bars, and a full line of All Terrain and Mud Terrain tires. Pro Comp also offers a light bar for 95-97 Tacomas. Contact dealer for details.

PLEASE NOTE:

Tire and wheel choice is crucial in assuring proper fit, performance, and the safety of your Pro Comp equipped vehicle. For this application, a wheel not to exceed 8" in width with a minimum backspacing of 3.25" must be used. Additionally, a quality tire of radial design, not exceeding 32" tall X 11.5" wide is recommended. Please note that the use of a 33" X 12.5" tire may require fender modification. Violation of these recommendations will not be endorsed as acceptable by Pro Comp Suspension and will void any and all warranties either written or implied.

PRIOR TO INSTALLATION:

- **Installation by a professional mechanic is recommended. Use of the appropriate power tools, a Toyota Tacoma service manual and a shop hoist can greatly reduce installation time.**
- **Check the production date of your vehicle. Vehicles manufactured prior to 10/95 may require additional parts to complete installation. If the front end alignment cams measure 1.85" in diameter, contact your Toyota Dealer for the cam bolts that are used on the 10/96 or later production vehicles or contact Pro Comp Suspension for adapter parts.**
- **Read the instructions carefully and study the illustrations before attempting installation. Pro Comp Suspension is not responsible for damage, failure or injury resulting from improper installation or parts substitution of this kit.**
- **Check all parts and hardware against the parts list to assure that your kit is complete. The parts and hardware supplied are of high grade material and must not be replaced by inferior parts or failure may result.**
- **Separating parts according to the areas they will be used and placing the hardware with the brackets before you begin will save installation time.**
- **This kit is supplied as a bolt-on assembly. Do not weld anything to the components and do not weld the components to the vehicle.**
- **All components in this kit come with a protective coating. Do not plate (i.e. chrome, cadmium, zinc etc.) or otherwise alter the finish in anyway. This could weaken the structural strength of the components.**
- **Always wear safety glasses when using power tools.**
- **Foot pound torque readings are listed on the Torque Specifications Chart at the end of the instructions unless specifically stated in an instruction. DO NOT USE AN IMPACT WRENCH TO TIGHTEN ANY OF THE BOLTS.**
- **Measure vehicle ride height.**

Front Installation:

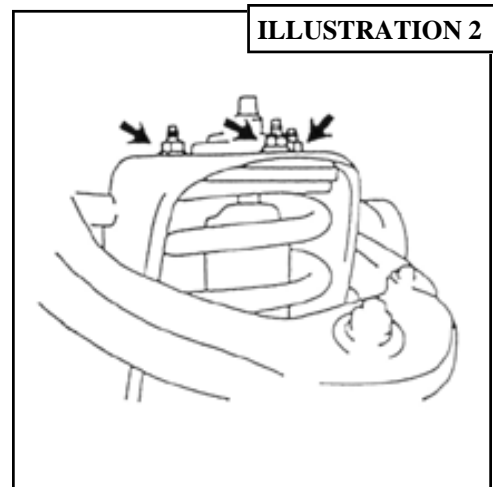
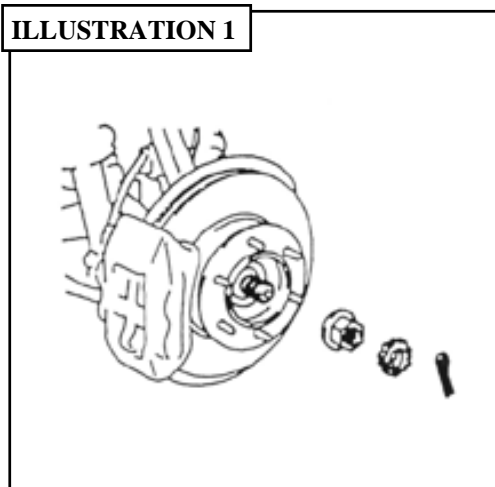

- 1) Remove grease cap, cotter pin and locking cap (ILLUSTRATION 1). While applying brakes, loosen axle nuts with a 35mm socket. Do not remove at this time.
- 2) Block rear wheels, set parking brake, raise front of vehicle and support with jack stands. Do not work on any vehicle unsupported by jackstands. Remove front wheels, tires and O.E.M. skid plates.
- 3) Place a jack under front lower a-arm. Remove lower nut from front shock mount. Next, locate the three (3) nuts at the top of the front shock (ILLUSTRATION 2). Remove these nuts. Lower a-arm and remove front shock. Repeat step 3 on the opposite side.

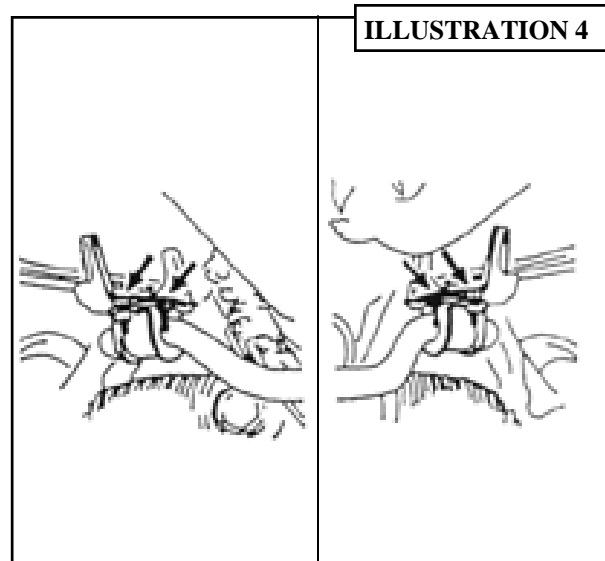
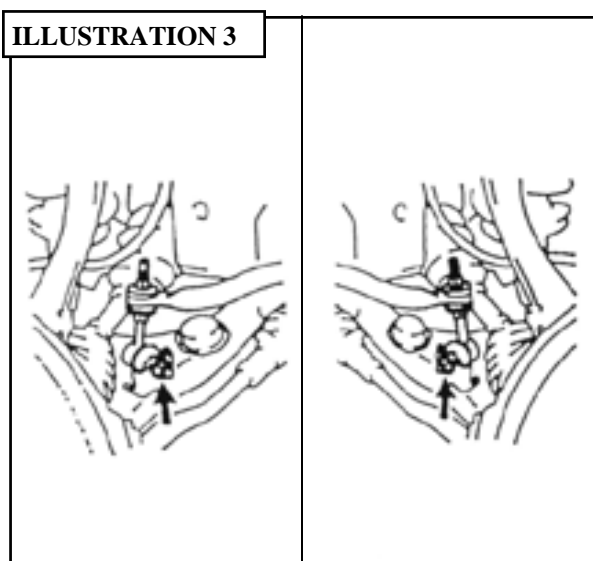

- 4) Locate and remove the nut, retainer collar and cushion that attaches the sway bar end to lower a-arms (ILLUSTRATION 3). Remove the two brackets that attach the sway bar to the frame. (ILLUSTRATION 4) Set this assembly aside.
- 5) Detach bolt and brake line hose clamp from the front spindle (ILLUSTRATION 5). Next remove

ILLUSTRATION 5



ILLUSTRATION 6



the two (2) bolts that attach brake caliper to front spindle. Support the brake caliper securely so it cannot swing freely.

ILLUSTRATION 7

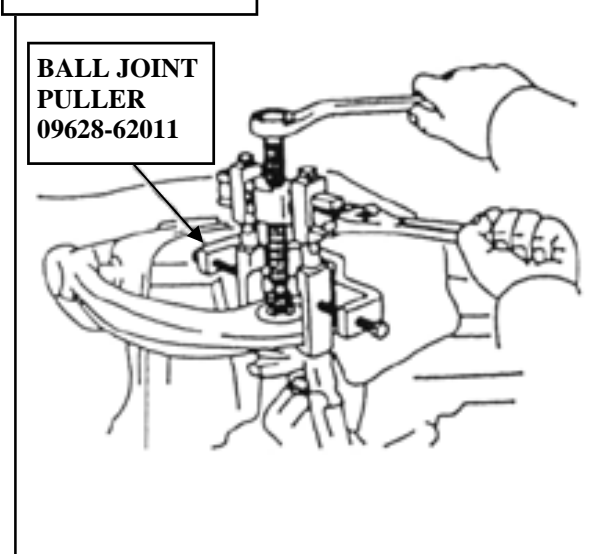
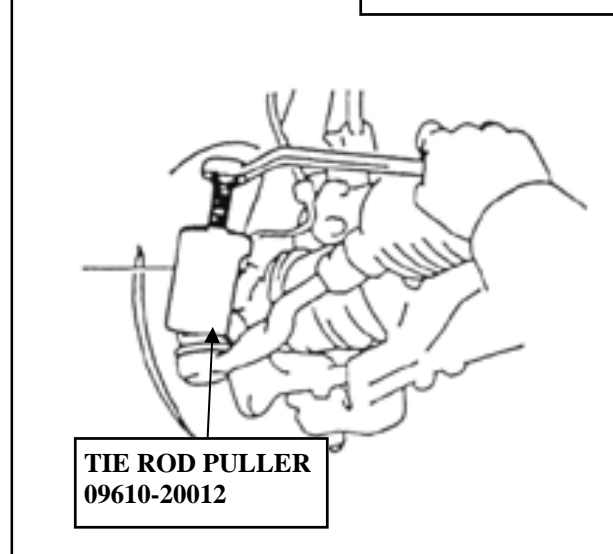

ILLUSTRATION 8



6) Remove rotor (ILLUSTRATION 6) by using a snap ring expander and removing the snap ring. (Some models may not have snap rings).

7) Using a strap, support the front drive axle from resting at full bind. Remove the cotter pin and loosen nut located on upper front spindle. Disconnect using the ball joint puller. Toyota #09628-62011 (ILLUSTRATION 7).

8) Next, remove the cotter pin and nut located at tie rod ends. Using the tie rod puller, Toyota

#09610-20012 (ILLUSTRATION 8), disconnect tie rod ends.

9) Locate the four (4) bolts attaching the lower ball joint on the a-arm to the front spindle (ILLUSTRATION 9). Remove the four bolts, axle nut and spindle

10) Locate the power steering unit. Disconnect the pressure feed and return lines at control valve housing. Make sure that you have a pan to catch the power steering fluid as you disconnect these lines. Remove steering unit from chassis.

NOTE: IT IS VERY IMPORTANT TO CENTER STEERING WHEEL AND LOCK IN THIS POSITION BY REMOVING KEY FROM THE IGNITION. DO NOT UNLOCK OR ROTATE THE STEERING WHEEL UNTIL YOU HAVE COMPLETED STEP 23 IN INSTRUCTIONS. ROTATING THE STEERING WHEEL WITH THE STEERING UNIT DISCONNECTED WILL DAMAGE THE SPIRAL CABLE IN THE STEERING COLUMN CAUSING THE AIR BAG, HORN AND CRUISE CONTROL SYSTEM TO FAIL.

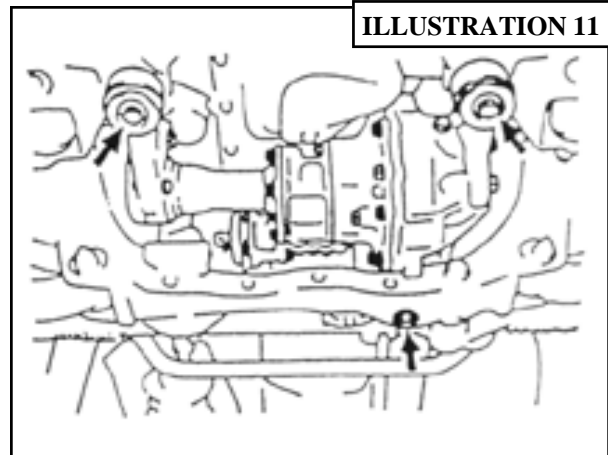
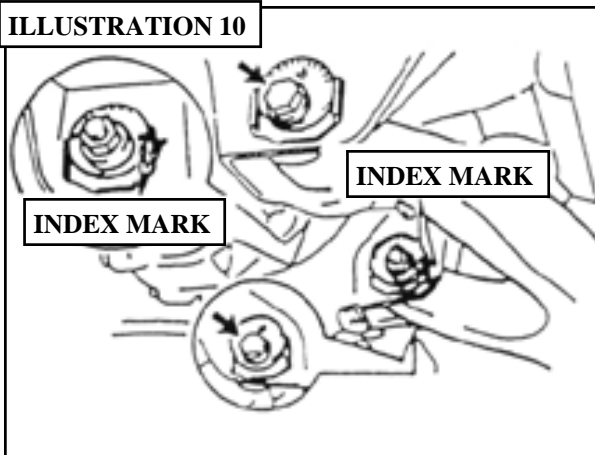
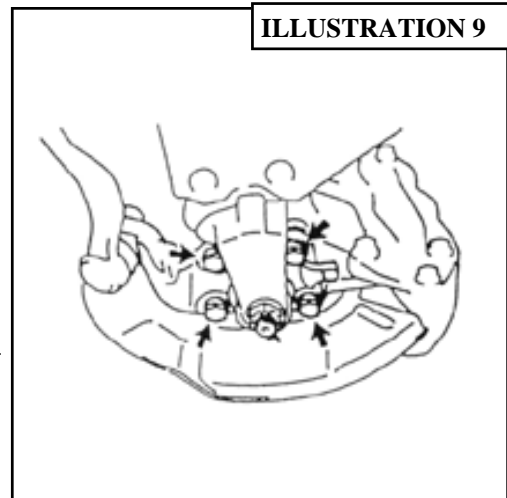

11) Place an index mark on the front and the rear of both adjusting cam-bolts (ILLUSTRATION 10). Remove nuts, adjusting cam-bolts and lower a-arms.

Repeat steps 5 through 11 on the opposite side, omitting step 10.

12) Place hoist stand under front differential u-joint. Using the 12mm allen socket, remove mounting bolt on rear crossmember (ILLUSTRATION 11). Remove the mounting bolts on the front differential mounting cushions. **NOTE: Using hoist stand, raise differential so rear crossmember can be removed. Save existing flanged nut it will be re-used when installing ball joint in step #25.**

13) Mark "cut lines" on rear crossmember as shown in ILLUSTRATION 12. (Relocate the vacuum lines behind crossmember before cutting). Using reciprocating saw, cut on cut lines, being careful not to damage or cut the a-arm boot. Locate the O.E.M. skidplate mount tabs and cut them off. Grind and clean the cut areas of excess material.

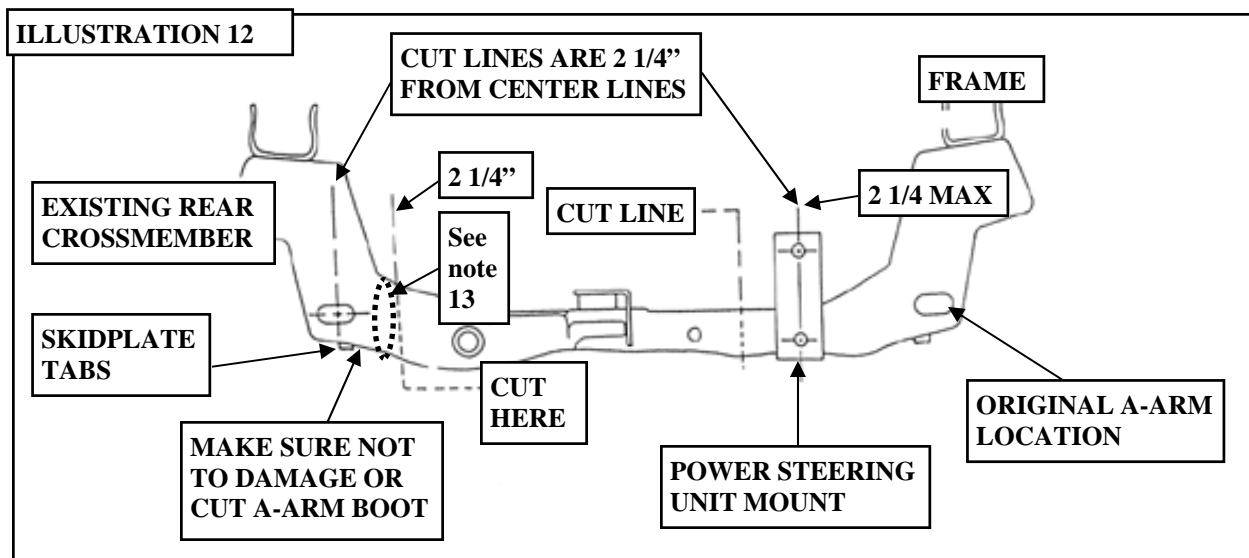

After cutting the crossmember, it is very important that the remaining material on the drivers side rear area be completely removed to clear the power steering adapter tube. Grind the material flush in the area indicated in (ILLUSTRATION 12).

- 14) Install crossmember support bracket (90-1344) to existing hole location on drivers side of lower a-arm mount (ILLUSTRATION 13). Use hardware provided. Do not tighten.

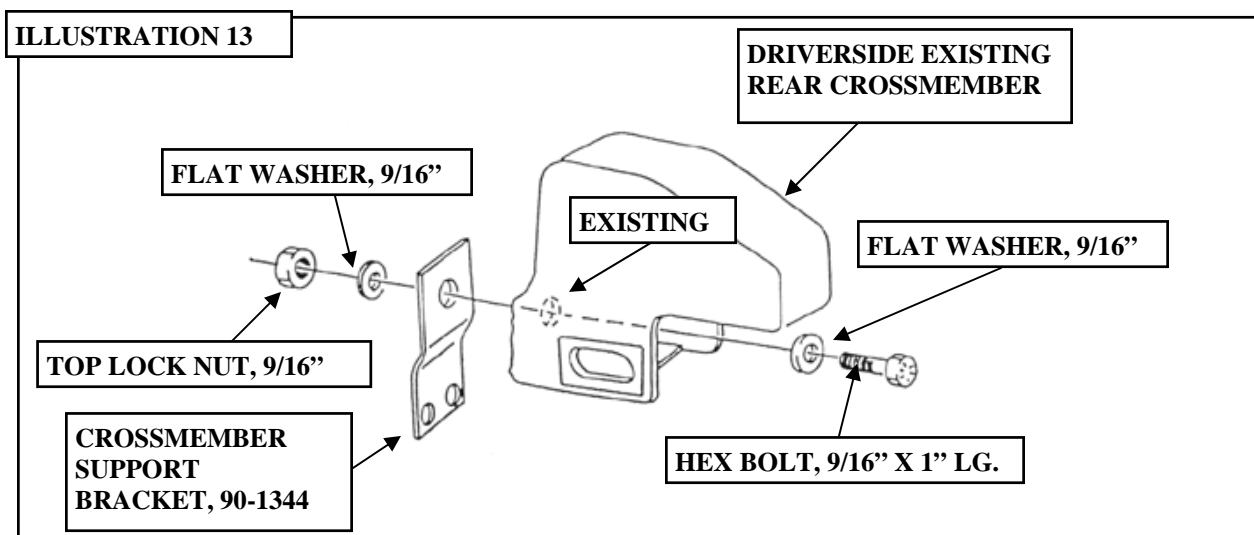

- 15) Position rear crossmember into existing lower rear a-arm mounting locations (ILLUSTRATION 15) using $3/4$ " x $4-1/4$ " hex bolts, locating washers (90-1345) and $3/4$ " top lock nuts; loosely fasten with the bolt heads towards the front of the vehicle.

- 16) Attach crossmember support bracket to rear crossmember, using the $3/8$ " hardware as shown in ILLUSTRATION 19. Remove existing O.E.M. stud. Install steering box support bracket (90-1336) using provided hardware as shown in ILLUSTRATION 16. Torque $3/4$ " top lock nut to 200-250 ft./lbs., $3/8$ " nyloc nuts to 37 ft./lbs., $9/16$ " and 14mm. hex bolts to 90 ft./lbs.

ILLUSTRATION 15

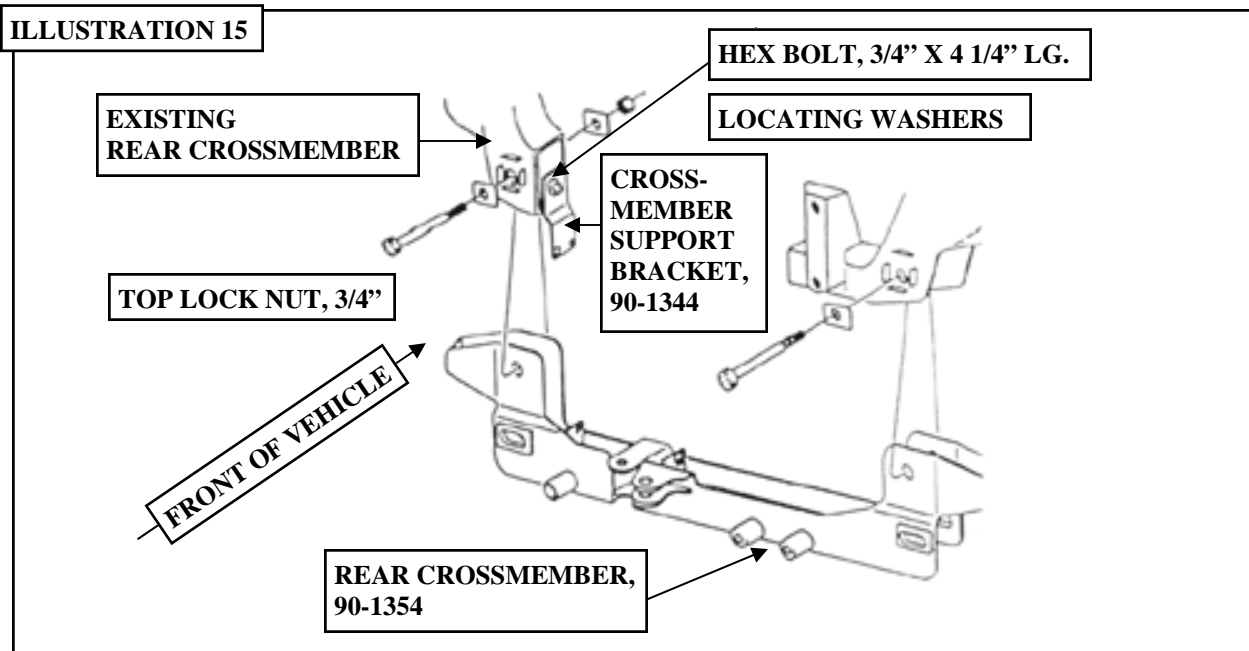

17) Next, position front crossmember (90-1332) into existing lower front a-arm mounting locations (ILLUSTRATION 17) using 3/4" x 4 1/4" hex bolts, locating washers (90-1345) and 3/4" top lock nuts; fasten loosely.

ILLUSTRATION 16

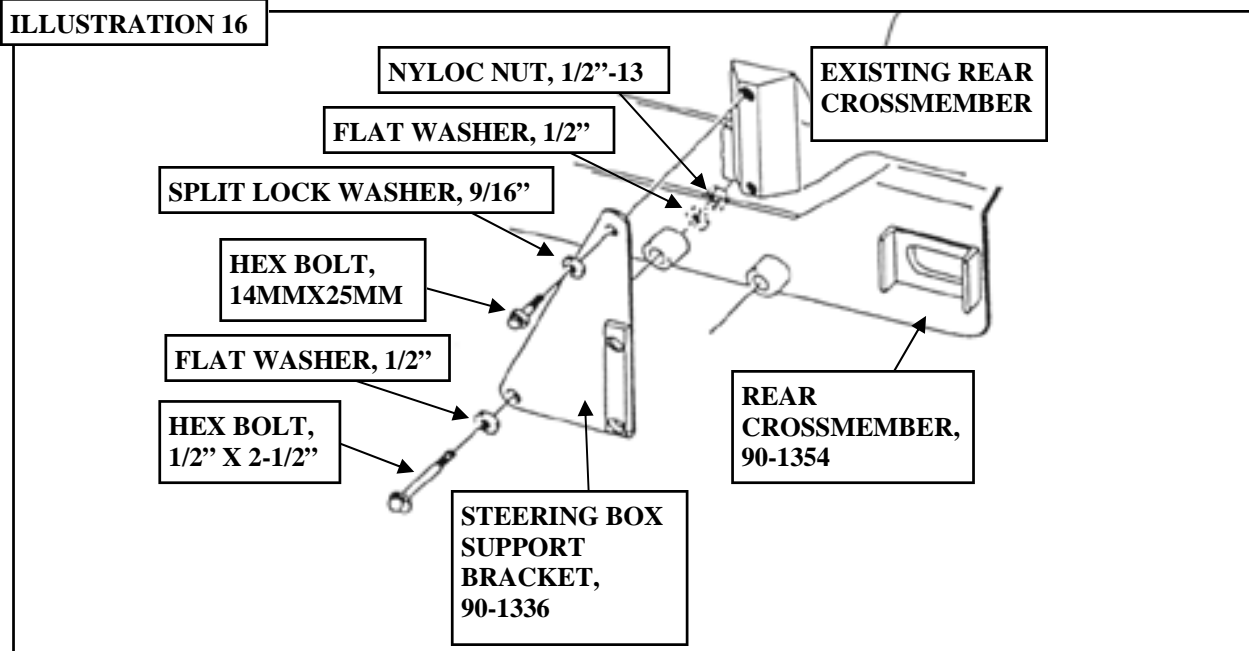

18) Lower differential slowly onto the front crossmember mounting cushions and rear crossmember mount. Make sure to check clearances around differential and area where rear crossmember section was cut away. Also, check to make sure that electrical wiring and tubing do not bind.

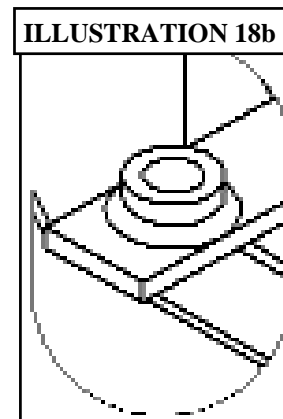
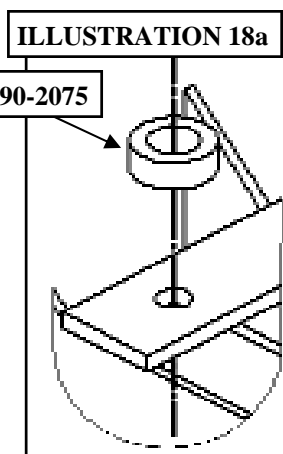
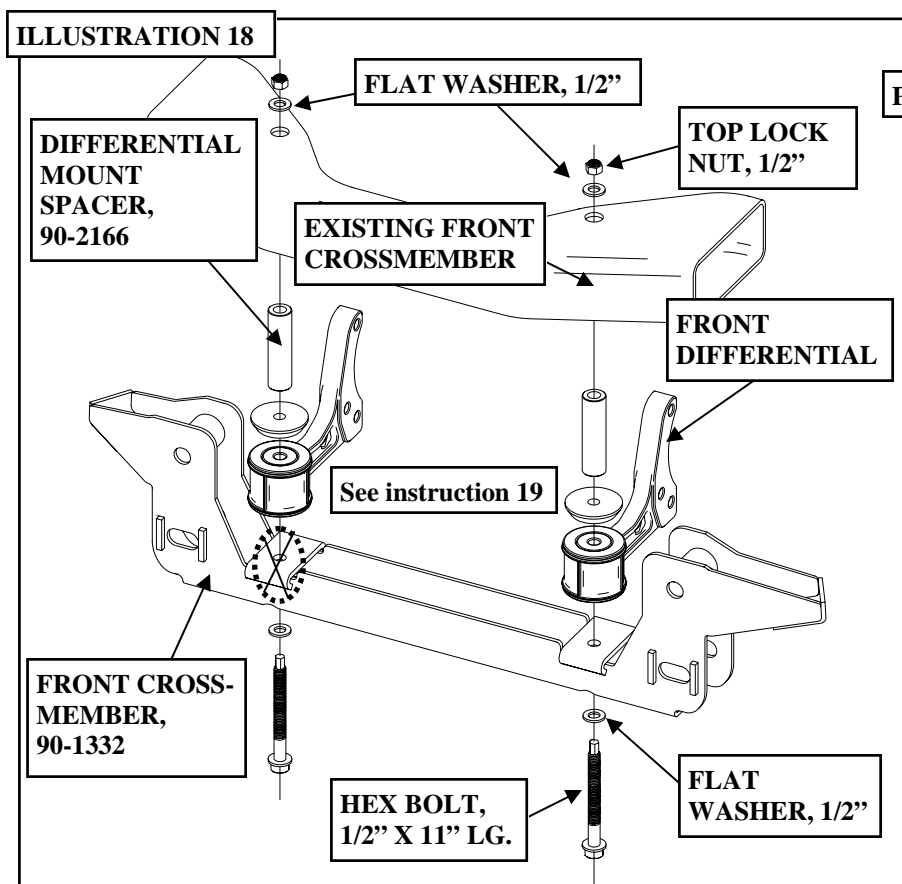
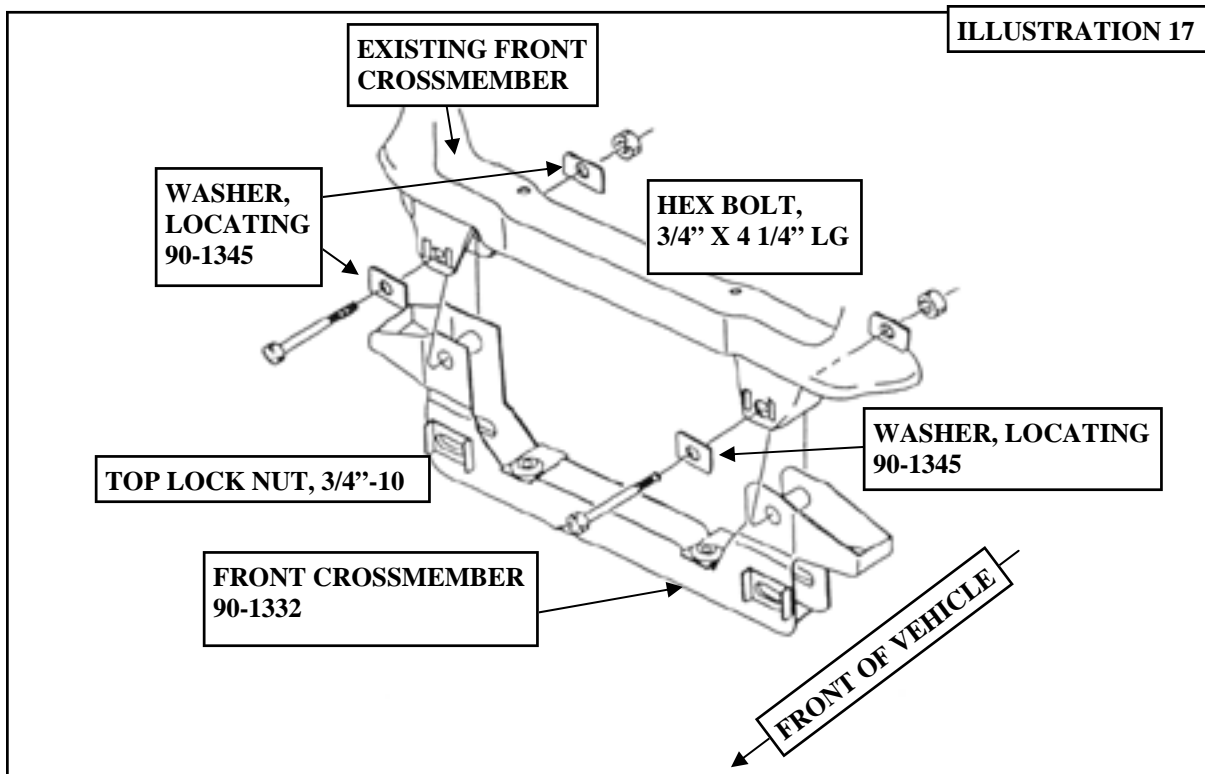

NOTE: There are currently two crossmembers being shipped. One has spacers welded as indicated in ILLUSTRATION 18b, one does not, ILLUSTRATION 18a. If you have a crossmember with the spacers welded in place, DO NOT use spacer (90-2075). If you DO NOT have the spacers welded in place, you must use these spacers as indicated.

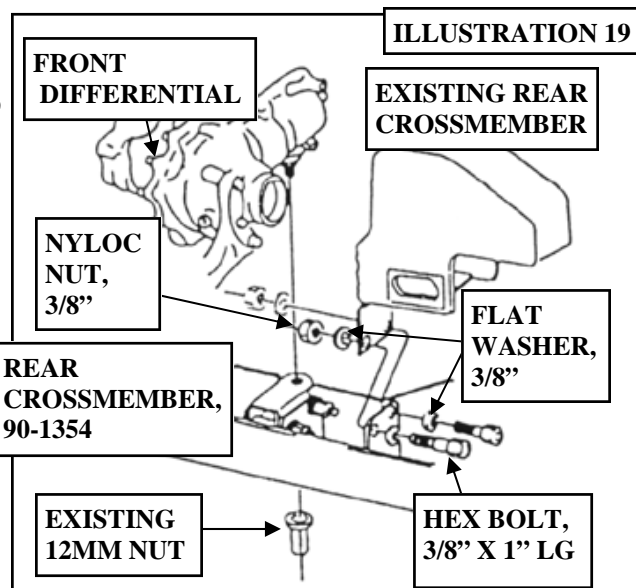

19) Using the differential mounting spacers (90-2166), hex bolts 1/2" x 11" Lg. 1/2" washers and nuts, fasten differential to front crossmember (ILLUSTRATION 18). Fasten rear differential mount to rear crossmember using existing 12mm hardware. (ILLUSTRATION 19). Torque 1/2" nuts to 90 ft./lbs. and existing 12mm nut to 64 ft./lbs.

20) Install existing lower a-arm into the front and rear crossmember on both sides of the vehicle using the existing front and rear adjusting cam-bolt assemblies (ILLUSTRATION 20). Refer to the index marks on the cam-bolts. Snug hardware, but do not tighten.

21) Install the steering yoke extension (90-2169) onto the splines of the lower steering shaft. Fasten, using button head, 5/16" hardware (ILLUSTRATION 21). Compare 90-2169 to the factory yoke paying close attention to the indexing of the clamp bolt and the lower bolt holes. Two different versions exist from the factory and the rubber isolator may need to be removed and rotated 90 degrees to properly center the steering wheel.

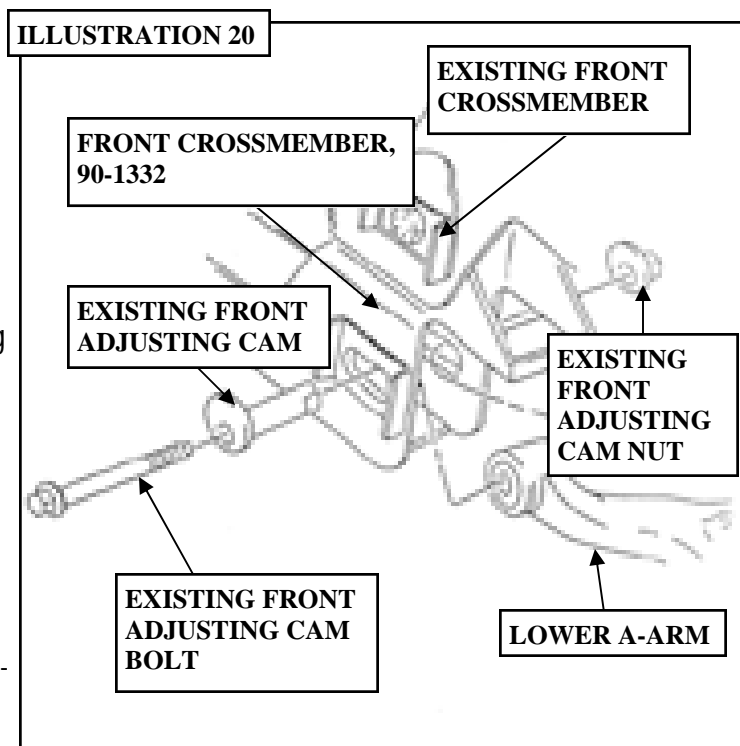

22) Loosely attach pressure line (90-4029) to control valve on power steering unit (ILLUSTRATION 22).

23) Install the power steering return line (90-4030) to the spool valve (ILLUSTRATION 23). Orient the return line nipple to the vertical position and snug down.

24) Install power steering unit (ILLUSTRATION 24) using hardware provided; fasten loosely. Slide steering shaft down into place on control valve coupler (ILLUSTRATION 21), then tighten and torque nuts to 26 ft./lbs. Tighten 5/16" button head bolt using loctite. Attach pressure line to existing location and hand tighten, being careful not to twist O.E.M.

hose. Attach return line to existing location on vehicle using hose clamp at the end of the return line (Refer back to ILLUSTRATION 23). Tighten both return and pressure lines at control valve housing. Reconnect tie-rod ends to lower steering arm. (A new cotter pin should be used) Torque nut to 41 ft./lbs. Tighten all hardware. See torque specifications chart on the last page.

25) Next, press ball joint out of the front spindle using the ball joint puller. Be sure to remove the rubber dust boot and snap retaining ring off the ball joint. Repeat on opposite spindle. ILLUSTRATION 24 A and 24 B.

26) Install ball joint into spindle spacer (90-4013) using ball joint tool (90-2167) as shown in ILLUSTRATION 24 C. Place ball joint tool on top of spindle spacer. Use the shim washers and existing ball joint nut to pull the ball joint into the spindle spacer. Make sure the ball joint is seated properly.

27) Install spindle spacer and ball joint assembly into upper a-arm. (ILLUSTRATION 25) Place front axle in spindle and fasten spindle to steering arm using existing hardware. Attach upper spindle to spindle spacer using spindle support bracket (90-1328 Pass.) (90-1329 Drvr.). Fasten using 1/2" hardware to 60 ft./lbs., as shown. Using set screw and jamb nut, position spindle support bracket approximately 5 degrees from spindle. Set by tightening jamb nut. Fasten spindle to spindle support bracket using u-bolt hardware (020100) torque to 21 ft./lbs. Torque the upper ball joint nut to 80 ft./lbs.,

ILLUSTRATION 21

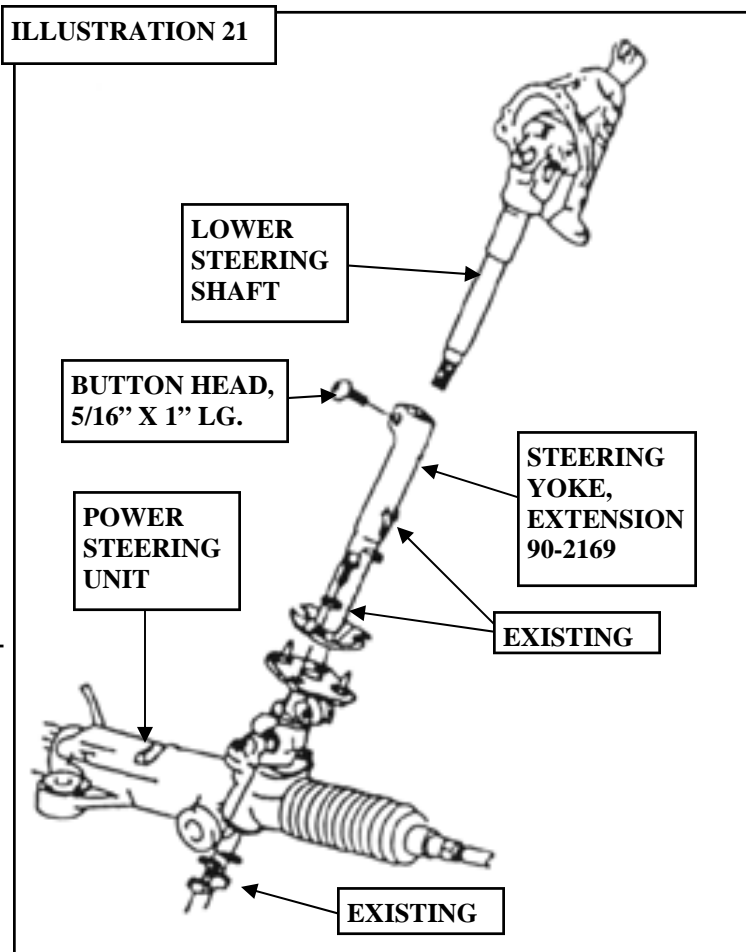

ILLUSTRATION 22

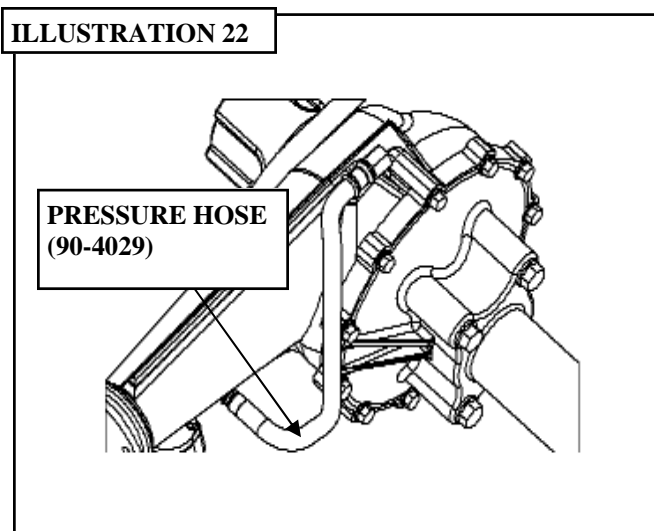

ILLUSTRATION 23

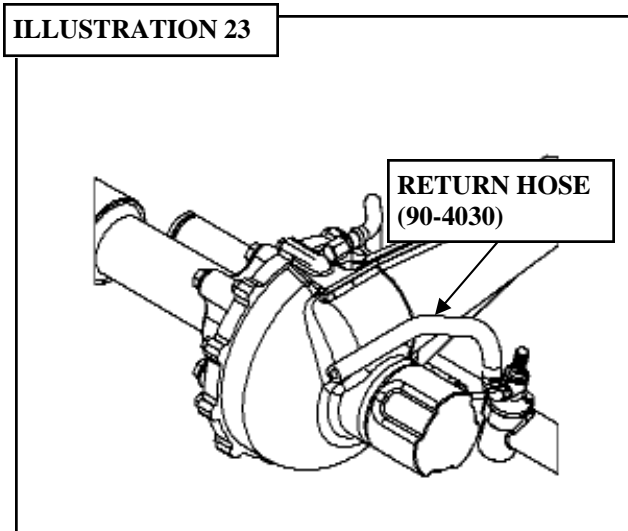

ILLUSTRATION 24

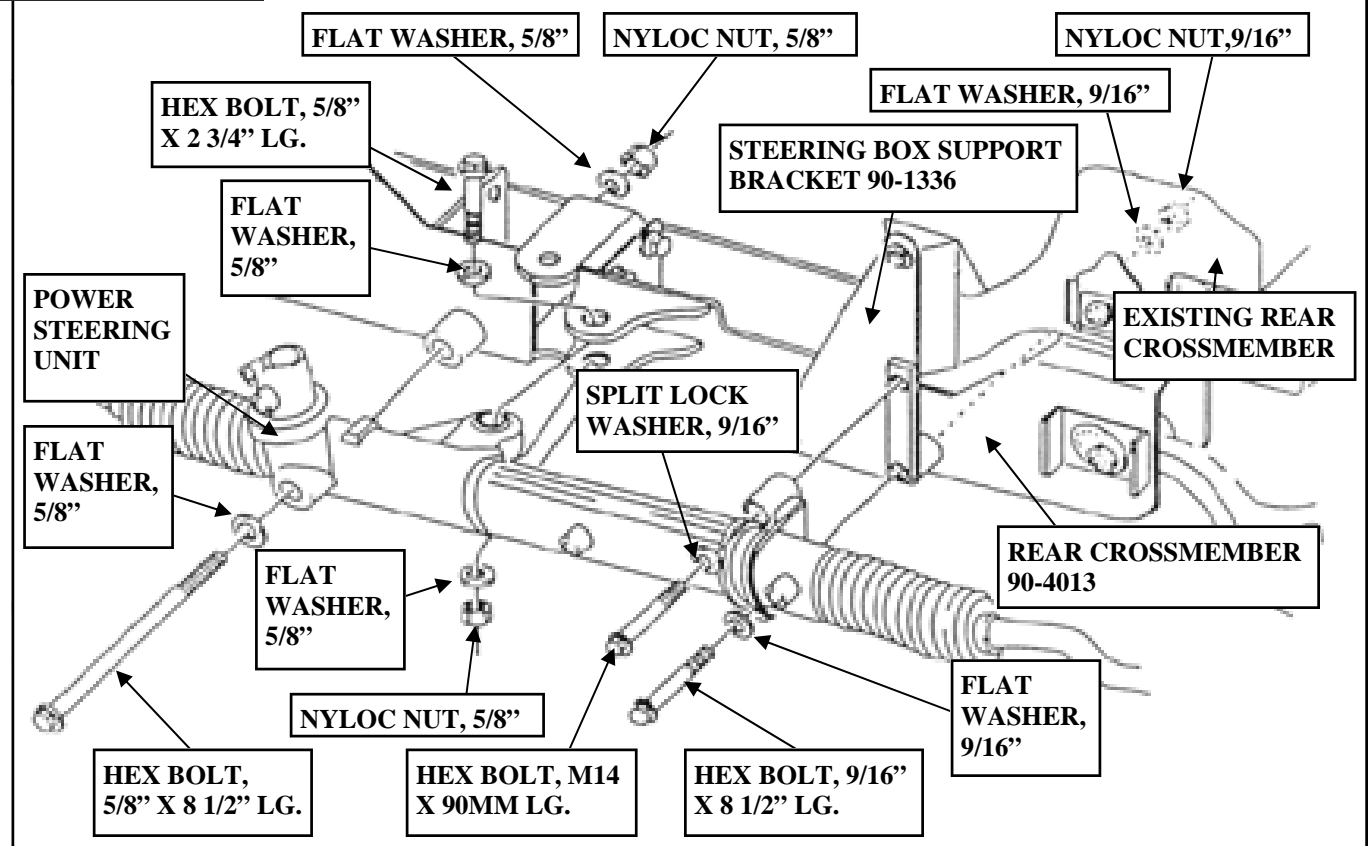

ILLUSTRATION 24A

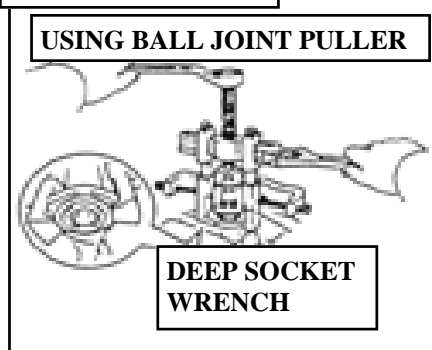

ILLUSTRATION 24B

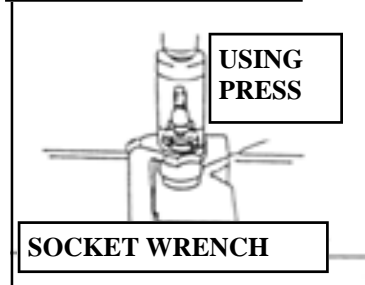
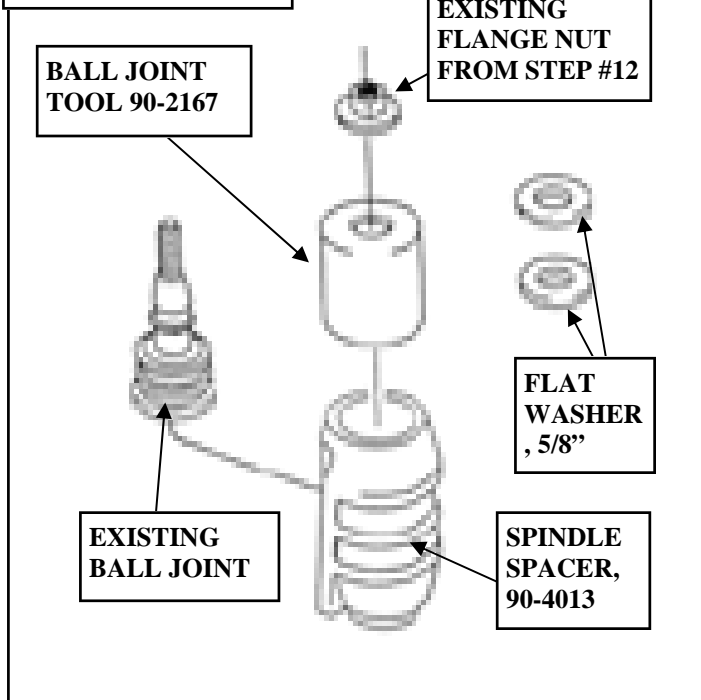
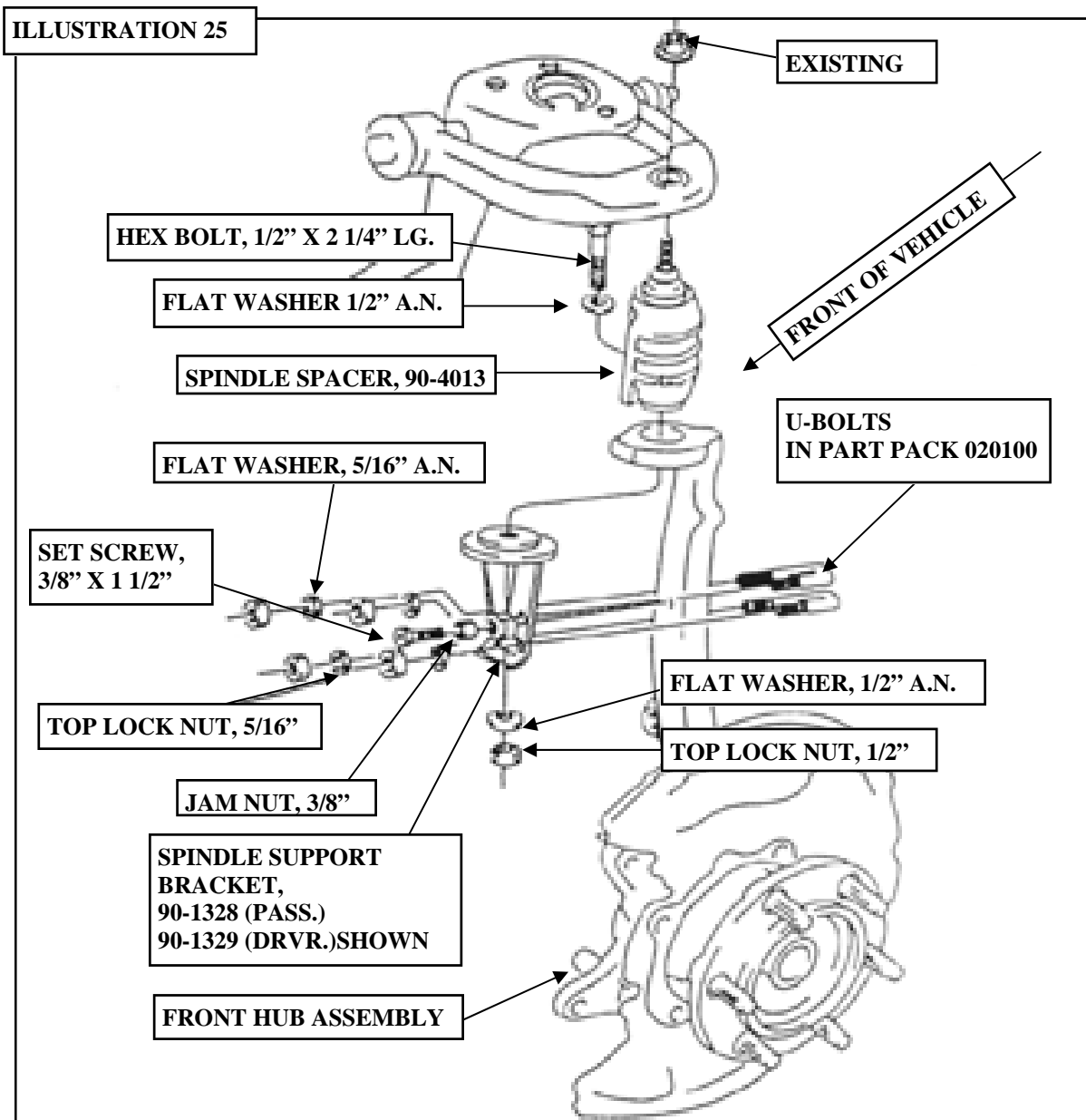

ILLUSTRATION 24C





the 1/2" nut attaching spindle spacer to spindle to 90 ft./lbs. and the steering arm nut to 83 ft./lbs.

28) Place rotors on hubs. Attach brake calipers to spindle. Fasten using existing hardware. Torque to 90 ft./lbs.

29) Remove stock brake lines and replace with required new longer brake line kit, **part # 7213**. Fasten following installation instructions in kit. Make sure that brake lines are positioned so they do not make contact with any moving parts.

30) Attach O.E.M. coil and shock to the new shock spacer (**90-4014**) using existing hardware. Torque to 47 ft./lbs. Next install shock spacer assembly into upper mount (ILLUSTRATION 26) using the 7/16" hardware provided. Install lower a-arm. Torque lower shock mount to 101 ft./lbs. and 7/16" hardware to

60 ft./lbs.

31) Install sway bar drop brackets (90-1339, Pass./90-1340, Drvr.) to existing sway bar upper mounting locations using existing hardware. (ILLUSTRATION 27). Torque hardware to 19 ft./lbs.

32) Install sway bar to sway bar mounting brackets with spacer (90-1508) installed as illustrated, using the 5/16" hardware provided. Do not tighten. Locate lower sway bar mount on lower a-arm. Fasten using existing hardware; torque to 51 ft./lbs. Torque 5/16" hardware to 21 ft./lbs.

33) Install skidplate (90-1369) using 3/8" hardware provided (ILLUSTRATION 28). Torque to 25 ft./lbs.

34) Install wheels and tires. Lower vehicle to ground. Tighten axle nut using 35mm socket to 174 ft./lbs. Attach locking cap, cotter pin and replace the dust cover.

35) Using your floor jack, raise the rear of the vehicle until the tires are off the ground. Support the vehicle using floor jacks on the vehicle frame in front of the rear axle. Carefully lower the floor jack and remove it from the work area.

36) Remove the wheels.

37) Remove the OEM brake lines and replace them with the new brake lines #7213. Be very careful and do **NOT** let the master cylinder run dry! With ABS brakes this situation will damage the system.

38) Remove the OEM shock absorbers.

39) Locate the ABS wiring harness located across the top of the differential housing. Disconnect the harness connector at the frame and remove the mounting loom from the gas tank flange. Carefully secure this harness out of the way to avoid damage.

40) Disconnect the ABS valve link from the differential housing. (ILLUSTRATION 29)

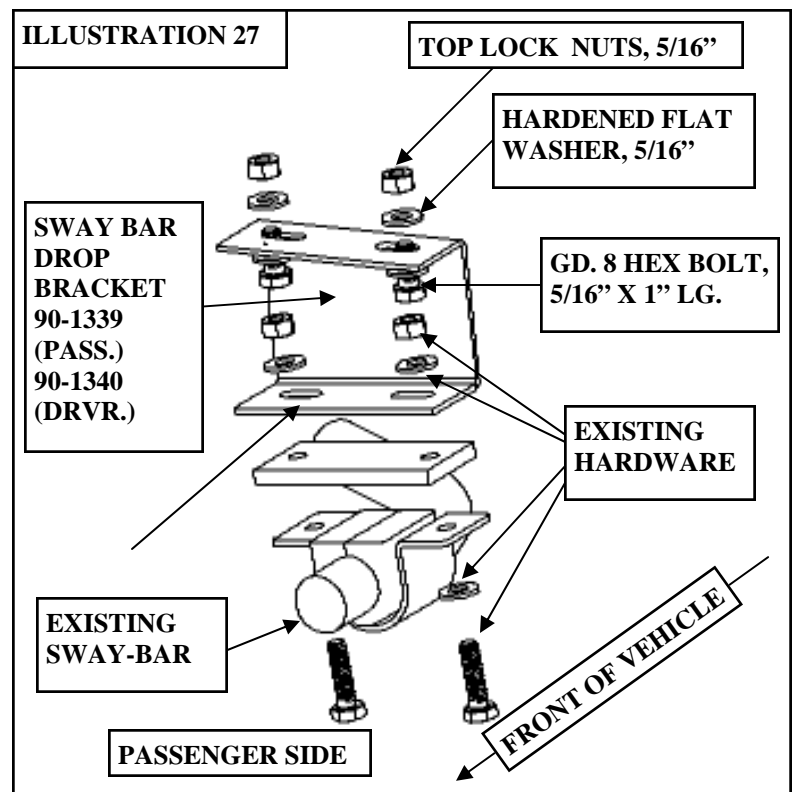
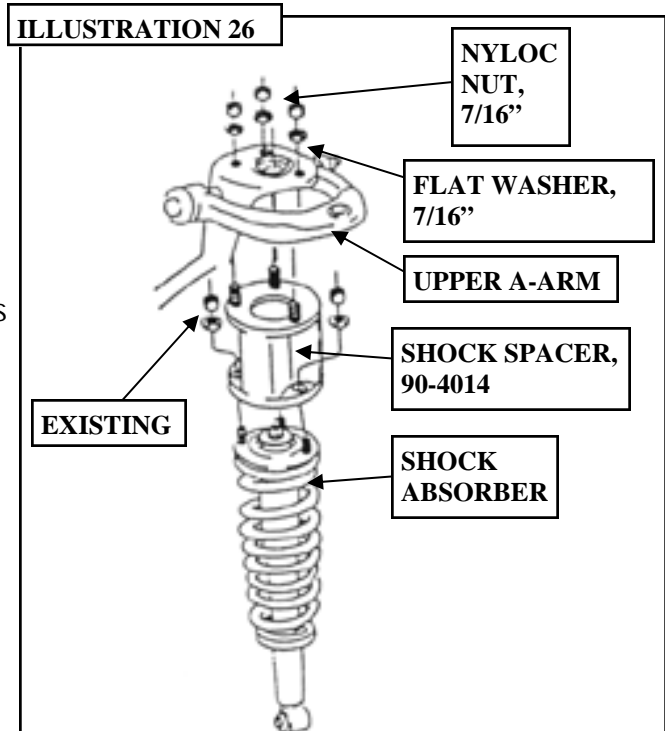

ILLUSTRATION 28

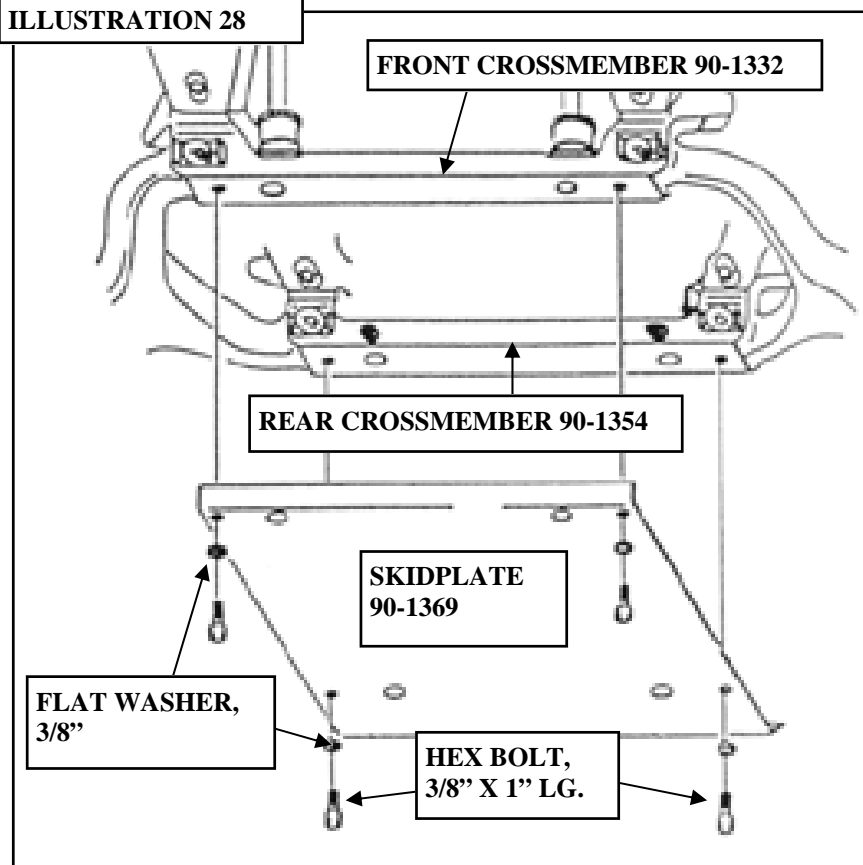
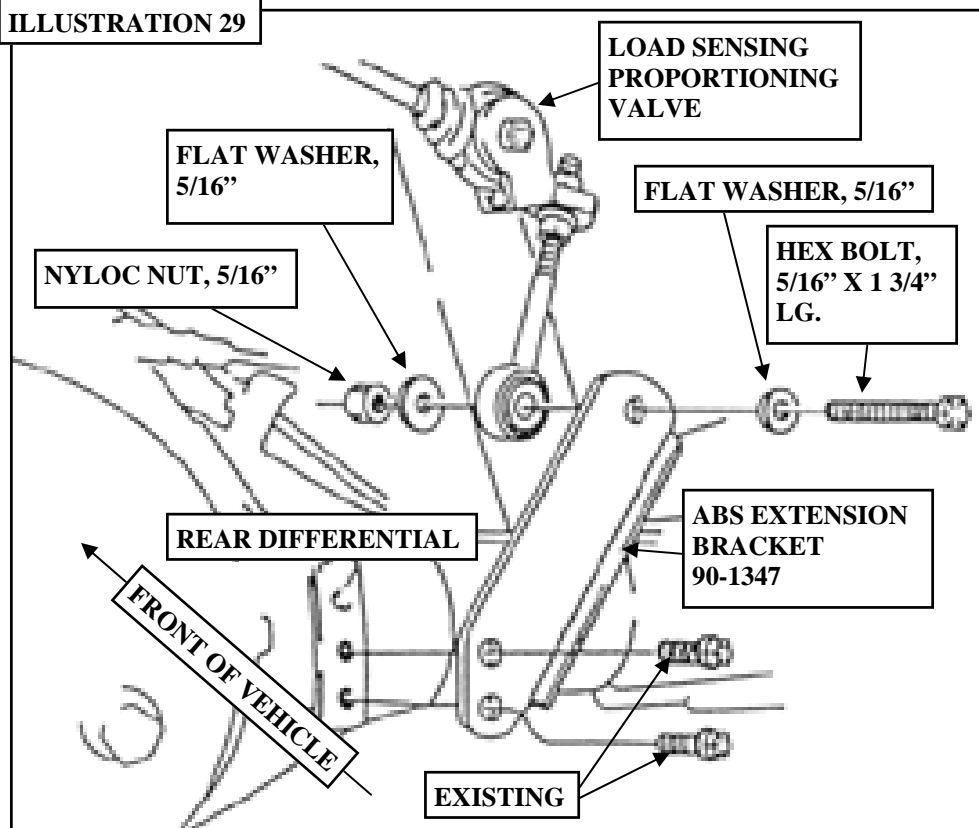
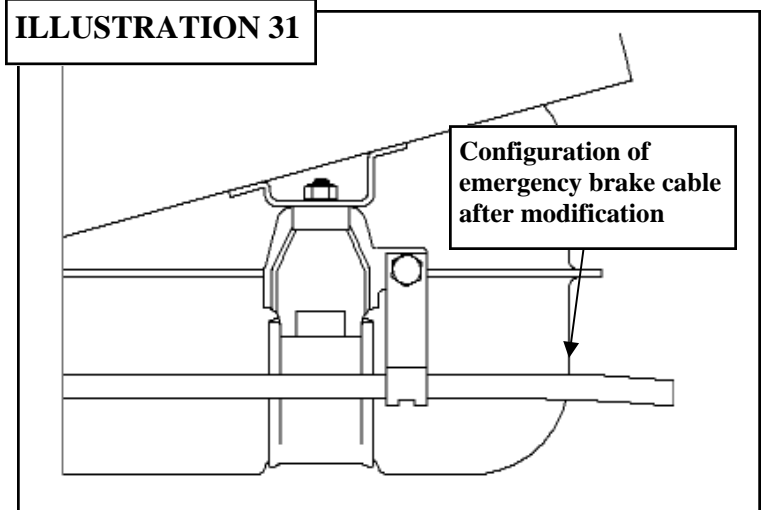
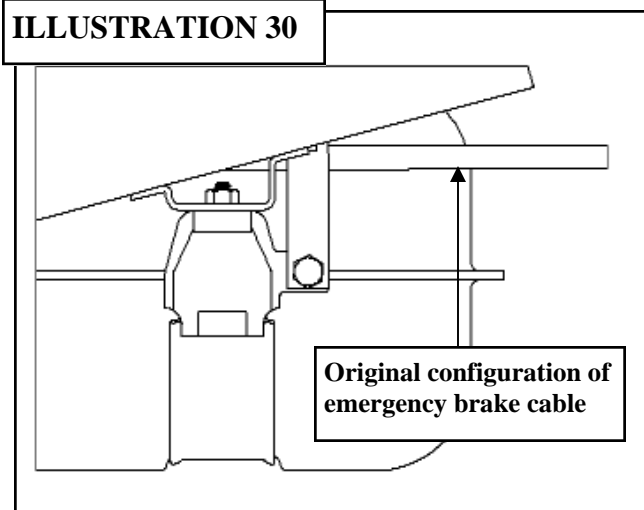
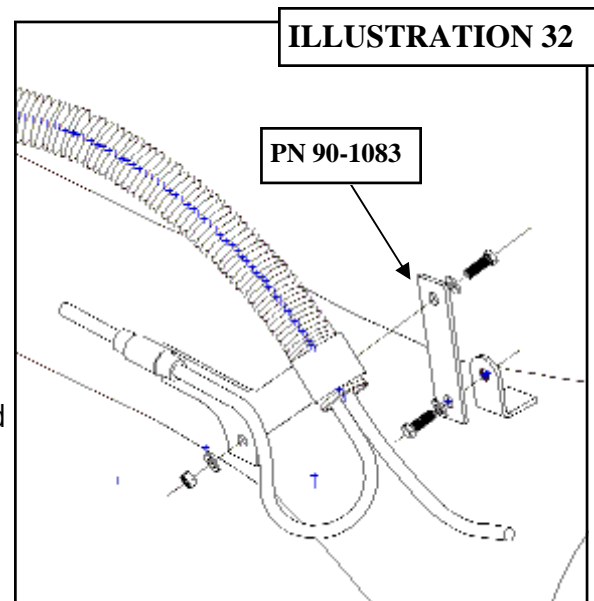

ILLUSTRATION 29





- 41) Disconnect the emergency brake cables from the brake drum backing plates. (Both sides).
- 42) On the driver side of the vehicle at the rear of the gas tank, remove the emergency brake cable bracket from the gas tank clamp. See ILLUSTRATION 30.
- 43) While supporting the gas tank, remove the gas tank retaining bolt and swing the gas tank clamp down, reroute the above mentioned cable outside and below the clamp as seen in ILLUSTRATION 31. Reattach the gas tank clamp.
- 44) Carefully rotate the emergency brake cable bracket 180 degrees and reattach the cable to its original mount. See ILLUSTRATION 30 and 31.



- 45) Working on one side of the vehicle at a time: Support the side you are working on with the floor jack, remove the U-bolts from the differential mount pad and carefully lower the housing enough to insert the lift block. These blocks are slightly tapered and the short side of the taper is oriented to the front of the vehicle. Install the U-bolts supplied, and tighten just enough to keep this side in place. Leaving the u-bolts slightly loose will make the remaining installation easier. Repeat this procedure on the other side of the vehicle. When both sides are in position, torque the nuts evenly to the torque specified in rear block installation kit instructions.
- 46) Reroute the emergency brake cable to the underside of the leaf springs and reattach the cables at the drum backing plates.
- 47) Connect the proportioning valve link (90-1347) as shown using the OEM bolts on the bottom, and the provided hardware on the top. See ILLUSTRATION 29.
- 48) Remove the ABS wiring bracket from the differential and install the ABS wiring extension (90-1083)

as shown in ILLUSTRATION 32. Use the OEM bolt at the lower end and the supplied hardware at the top. Reconnect the ABS wire loom to the frame connector and reattach the loom to the gas tank.

49) Check all hardware at this time to ensure that everything is tight. Check for adequate clearance on all repositioned brake lines and emergency brake cables. Make sure you check with the suspension fully extended, and compressed.

50) Reinstall the tires, remove jack stands and lower to the ground.

• **AFTER INSTALLATION IS COMPLETE:**

- Re-check and tighten/torque all fasteners. See torque specifications chart.
- Re-check brake/steering systems. Be sure all hoses are long enough. Make sure there are no clearance/binding problems.
- Re-adjust headlights.
- Front end alignment is needed after installation. Set alignment to factory specs.
- Bleeding brakes and steering should be done according to the Toyota Tacoma service manual (page SR-10 and BR-1).

Use this only as a guide for hardware without a called out torque specification in the instruction manual.

Bolt Torque and ID						
Decimal System			Metric System			
All Torques in Ft. Lbs. Maximums						
Bolt Size	Grade 5	Grade 8	Bolt Size	Class 9.8	Class 10.9	Class 12.9
5/16	15	20	M6	5	9	12
3/8	30	45	M8	18	23	27
7/16	45	60	M10	32	45	50
1/2	65	90	M12	55	75	90
9/16	95	130	M14	85	120	145
5/8	135	175	M16	130	165	210
3/4	185	280	M18	170	240	290

<p>1/2-13x1.75 HHCS</p> <p>D T L X</p>	<p>Grade 5 Grade 8</p> <p>(No. of Marks + 2)</p>	<p>M12-1.25x50 HHCS</p> <p>D T L X</p>
<p>G = Grade (Bolt Strength)</p> <p>D = Nominal Diameter (Inches)</p> <p>T = Thread Count (Threads per Inch)</p> <p>L = Length (Inches)</p> <p>X = Description (Hex Head Cap Screw)</p>		<p>P = Property Class (Bolt Strength)</p> <p>D = Nominal Diameter (Millimeters)</p> <p>T = Thread Pitch (Thread Width, mm)</p> <p>L = Length (Millimeters)</p> <p>X = Description (Hex Head Cap Screw)</p>

WHEEL ALIGNMENT SPECIFICATIONS:

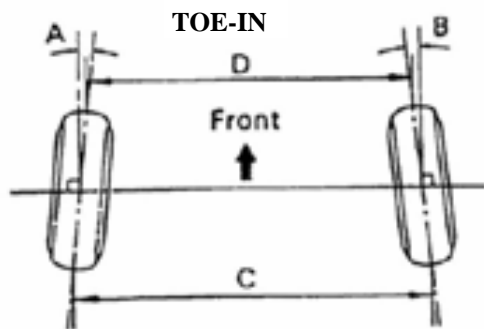

TOE-IN	$A + B = 0\dot{Y} + 0.1\dot{Y}$
TOTAL	$C - D = 0 + 1 \text{ MM } (0 + 0.04 \text{ IN.})$

*** IF THE TOE-IN IS NOT WITHIN THE SPECIFICATIONS, ADJUST THE RACK ENDS.**

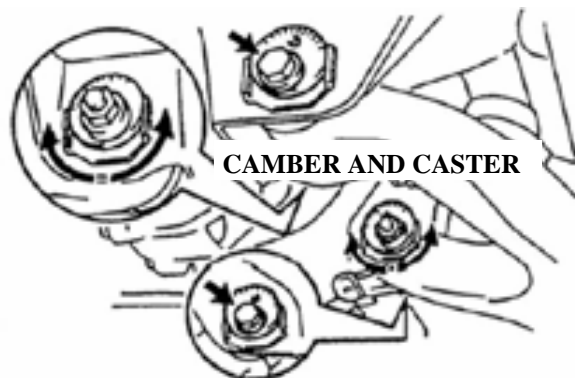

CAMBER AND CASTER

CAMBER	$-0\dot{Y}00' + 30'$
LEFT-RIGHT ERROR	$-30'$ or less
CASTER	$-2\dot{Y}50' + 30'$
LEFT-RIGHT ERROR	$-30'$ or less

*** ADJUST THE CAMBER AND CASTER BY FRONT AND/OR REAR ADJUSTING CAMS. TORQUE TO 127 FT./LBS.**

TOE-IN AND WHEEL ANGLE

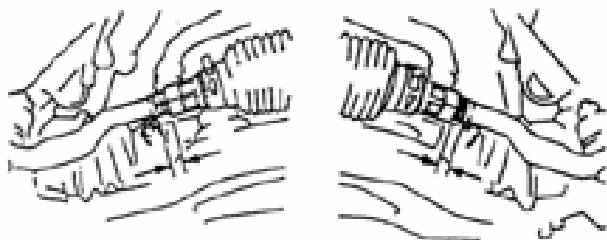

TOE-IN	$A + B = 0\dot{Y} + 0.2\dot{Y}$
TOTAL	$C - D = 0 + 2 \text{ MM } (0 + 0.08 \text{ IN.})$

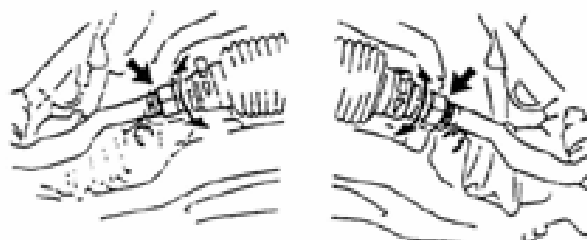

*** TURN THE LEFT AND RIGHT RACK END'S AN AMOUNT TO ADJUST THE TOE-IN. TORQUE TO 41 FT./LBS.**

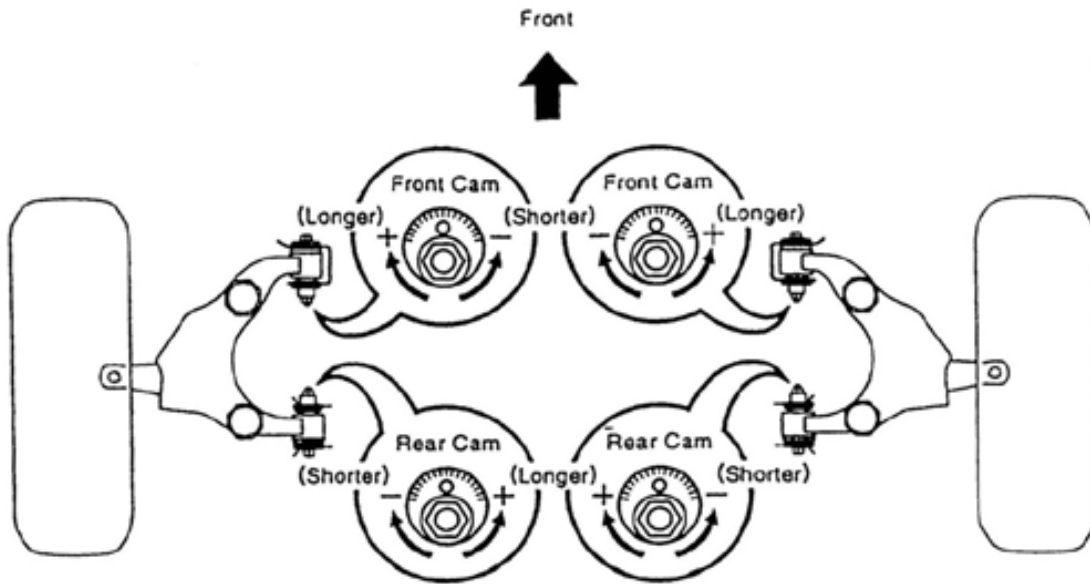

ITEM	INSIDE WHEEL	OUTSIDE WHEEL (REFERENCE)
MAX.	37°05' (35°05' - 38°05')	32°20'

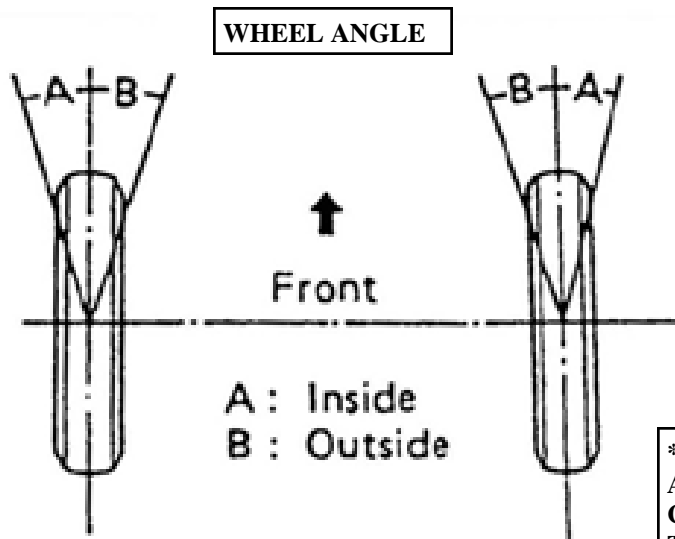

*** IF WHEEL ANGLE DEVIATES FROM THE SPECIFICATION READJUST THE TOE-IN AND WHEEL ANGLE WITHIN THE SPECIFICATIONS. AT THIS TIME, THE LENGTHS OF THE TIE ROD END MAY BE WITHIN LESS THAN 1.5MM (0.059 IN.)**

Notice to Owner operator, Dealer and Installer:

Vehicles that have been enhanced for off-road performance often have unique handling characteristics due to the higher center of gravity and larger tires. This vehicle may handle, react and stop differently than many passenger cars or unmodified vehicles, both on and off-road. You must drive your vehicle safely! Extreme care should always be taken to prevent vehicle rollover or loss of control, which can result in serious injury or even death. Always avoid sudden sharp turns or abrupt maneuvers and allow more time and distance for braking! Pro Comp reminds you to fasten your seat belts at all times and reduce speed! We will gladly answer any questions concerning the design, function, maintenance and correct use of our products.

Please make sure your Dealer/Installer explains and delivers all warning notices, warranty forms and instruction sheets included with Pro Comp product.

Application listings in this catalog have been carefully fit checked for each model and year denoted. However, Pro Comp reserves the right to update as necessary, without notice, and will not be held responsible for misprints, changes or variations made by vehicle manufacturers. Please call when in question regarding new model year, vehicles not listed by specific body or chassis styles or vehicles not originally distributed in the USA.

Please note that certain mechanical aspects of any suspension lift product may accelerate ordinary wear of original equipment components. Further, installation of certain Pro Comp products may void the vehicle’s factory warranty as it pertains to certain covered parts; it is the consumer’s responsibility to check with their local dealer for warranty coverage before installation of the lift.

Warranty and Return policy:

Pro Comp warranties its full line of products to be free from defects in workmanship and materials. Pro Comp’s obligation under this warranty is limited to repair or replacement, at Pro Comp’s option, of the defective product. Any and all costs of removal, installation, freight or incidental or consequential damages are expressly excluded from this warranty. Pro Comp is not responsible for damages and / or warranty of other vehicle parts related or non-related to the installation of Pro Comp product. A consumer who makes the decision to modify his vehicle with aftermarket components of any kind will assume all risk and responsibility for potential damages incurred as a result of their chosen modifications. Warranty coverage does not include consumer opinions regarding ride comfort, fitment and design. Warranty claims can be made directly with Pro Comp or at any factory authorized Pro Comp dealer.

IMPORTANT! To validate the warranty on this purchase please be sure to mail in the warranty card.

Claims not covered under warranty-

- Parts subject to normal wear, this includes bushings, bump stops, ball joints, tie rod ends and heim joints
 - Discontinued products at Pro Comp’s discretion
- Bent or dented product
- Finish after 90 days
- Leaf or coil springs used without proper bump stops
- Light bulbs
- Products with evident damage caused by abrasion or contact with other items
- Damage caused as a result of not following recommendations or requirements called out in the installation manuals
- Products used in applications other than listed in Pro Comp’s catalog
- Components or accessories used in conjunction with other manufacturer’s systems
- Tire & Wheel Warranty as per Pro Competition Tire Company policy
- Warranty claims without “Proof of Purchase”
- Pro Comp Pro Runner coil over shocks are considered a serviceable shock with a one-year warranty against leakage only. Rebuild service and replacement parts will be available and sold separately by Pro Comp. Contact Pro Comp for specific service charges.
- Pro Comp accepts no responsibility for any altered product, improper installation, lack of or improper maintenance, or improper use of our products.

E-Mail: tech@explorerprocomp.com
Website: www.explorerprocomp.com
Fax: (619) 216-1474
Ph: (619) 216-1444

PLACE
WARRANTY REGISTRATION
NUMBER
HERE: _____