



Installation Instructions

GMC Winch Bumper

Product Number: A2150-A2152

Application: 07.5-10 GMC 2500-3500 HD (Non-Classic)

SAFETY

Your safety and the safety of others is very important.

- In order to help you make informed decisions about safety, we have provided installation instructions and other information.
- These instructions alert you to potential hazards that could hurt you or others.
- Please do a job safety analysis (JSA) before each task to identify potential hazards for your situation and remove/protect against them.
- You must use your own good judgment, and take your time.

Read and understand all safety precautions and instructions before installing this product.

THIS PRODUCT IS FOR OFFROAD USE ONLY. ALL LIABILITY FOR INSTALLATION AND USE RESTS WITH THE OWNER.

CARELESS INSTALLATION AND OPERATION CAN RESULT IN SERIOUS INJURY OR EQUIPMENT DAMAGE.

Injury hazard

Failure to observe these instructions could lead to severe injury or death.

- Always** remove jewelry and wear eye protection.
- Always** use extreme caution when jacking up a vehicle for work. Set emergency brake and use tire blocks. Locate and use the vehicle manufacturers designated lifting points. Use jack stands.
- Always** use appropriate and adequate care in lifting components into place.
- Always** insure components will remain secure during installation and operation.
- Always** wear safety glasses when installing this kit. A drilling operation will cause flying metal chips. Flying chips can cause serious eye injury.
- Always** use extreme caution when drilling on a vehicle. Thoroughly inspect the area to be drilled (on both sides of material) prior to drilling, and relocate any objects that may be damaged.
- Always** use extreme caution when cutting and trimming during fitting.
- Always** tighten all nuts and bolts securely per installation instructions.
- Always** route electrical cables carefully. Avoid moving parts, components that become hot and rough or sharp edges.
- Always** insulate and protect all exposed wiring and electrical terminals.
- Always** perform regular inspections and maintenance on mounts and related hardware.



Installation Instructions

GMC Winch Bumper

Product Number: A2150-A2152

Application: 07.5-10 GMC 2500-3500 HD (Non-Classic)

I. Overview

Congratulations on your purchase of the industries' best and most stylish Chevy Winch Bumper! This bumper has been **engineered** for strength while keeping the weight down. It can accept the Warn 16.5 winch... and look cool doing it.

This product has also been **engineered** to allow alignment in three directions so you will end up with a very professional fit.

Your bumper was designed in 3-D from digitized data, CNC laser cut, fabricated, and powder coated... all in the U.S.A.

Enjoy the fit and finish of a quality Chevy Winch Bumper from Fab Fours Inc!

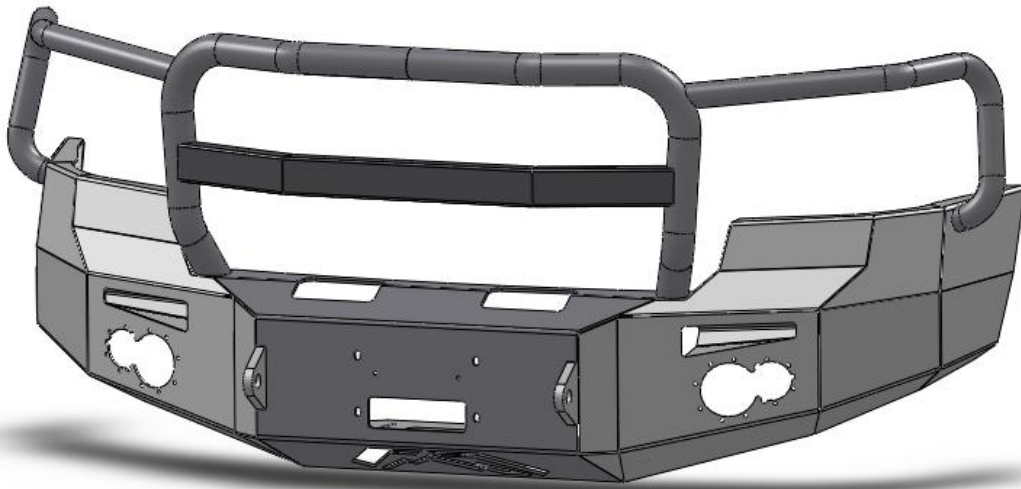



Installation Instructions

GMC Winch Bumper

Product Number: A2150-A2152

Application: 07.5-10 GMC 2500-3500 HD (Non-Classic)

II. Tools Required

- Multi meter or circuit test light
- Socket Wrench With Extensions
- 5/32" Allen Wrench
- 1/8" Allen Wrench
- 15mm Socket
- 18mm Socket
- 21mm Deep Socket
- 7/32" Socket
- 3/4" Socket
- 18mm Open End Wrench
- 3/4" Open End Wrench
- 7/16" Open End Wrench
- 3/8" Open End Wrench
- Phillips Screwdriver
- Hammer

III. Vehicle Preparation

1. Disconnect the wiring harness from both fog lights.
2. Open the Hood and remove the 8 dart clips holding the plastic radiator valance. See Image Below

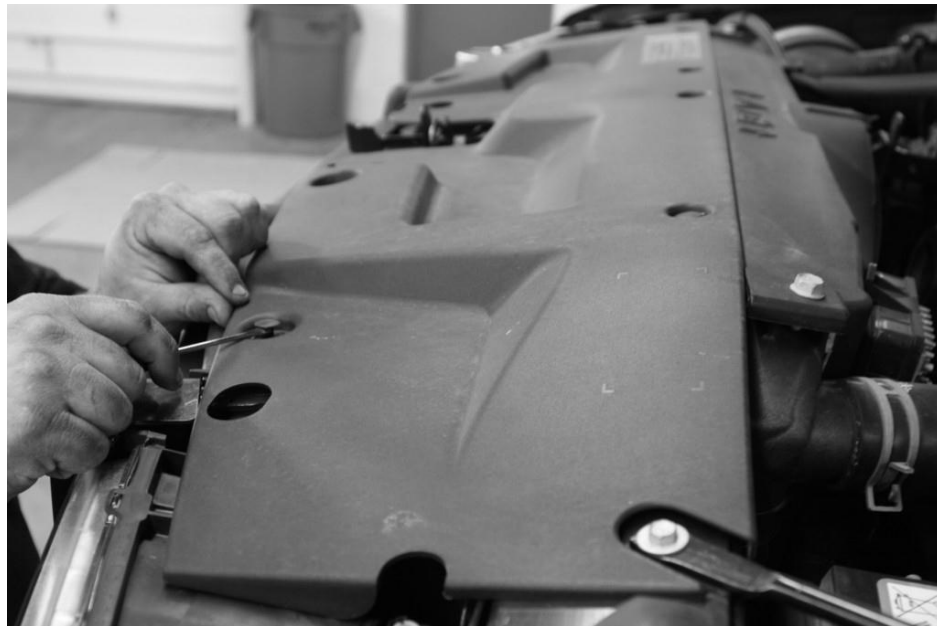

Figure 1 – Clip Removal



Installation Instructions

GMC Winch Bumper

Product Number: A2150-A2152

Application: 07.5-10 GMC 2500-3500 HD (Non-Classic)

3. Remove the two 7mm screws from the plastic piece from inside the wheel well. Repeat on other side. See Image Below



Figure 2 - Valence Fasteners

4. Reaching behind the grill use needle nose pliers or a flat bladed screwdriver to pop loose all clips holding the painted bumper section to the grill.
5. Remove the Painted Bumper section from the front of the truck. See Image Below



Figure 3 - Plastic Section Removal

6. Remove the clips holding the rubber splash mat between the frame and the bumper. Also remove the two clips attaching the rubber valance to the grill.



Installation Instructions

GMC Winch Bumper

Product Number: A2150-A2152

Application: 07.5-10 GMC 2500-3500 HD (Non-Classic)

7. Remove the two screws connecting the outer bumper support bar to the body mount bracket (15mm). Loosen the screw connecting the outer bumper support bar to the bumper (15mm), allowing it to rotate downward

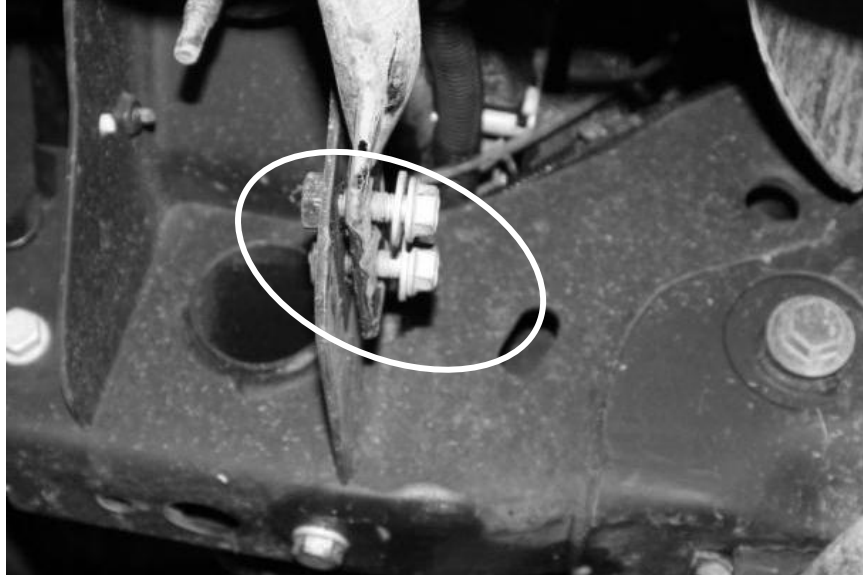

Figure 4 – Outer Bumper Support Screws

8. Remove the two main bumper bracket nuts per side. DO NOT REMOVE THE BOLT STRIPS WITHOUT SUPPORTING THE BUMPER.

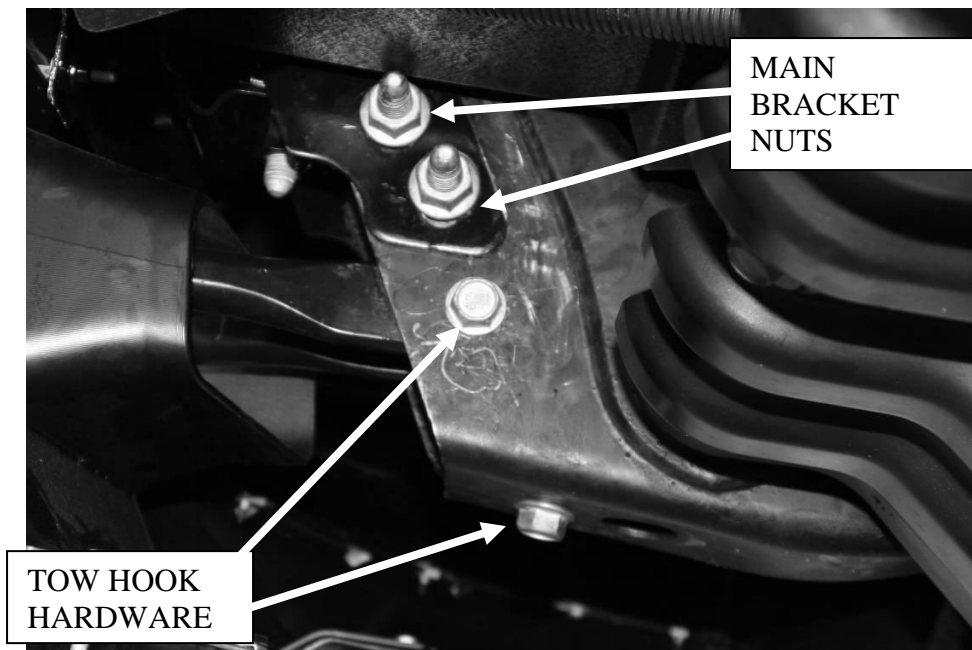

Figure 5 - Tow Hook and Main Bracket Hardware



Installation Instructions

GMC Winch Bumper

Product Number: A2150-A2152

Application: 07.5-10 GMC 2500-3500 HD (Non-Classic)

9. With the weight of the bumper supported, remove the stud plates and pull the bumper forward away from the truck
10. Remove the two fasteners per tow hook (18mm) and pull tow hook out from the front of the truck.
11. Remove the two plastic brackets at the front of each fender by removing the two dart clips from the wheel well and the three 10mm bolts. See Image Below:



Figure 6 - Plastic Bracket

12. Remove the headlight by removing two 10mm bolts from the top, one 10mm bolt from the front, and one 10mm bolt from the side.



Installation Instructions

GMC Winch Bumper

Product Number: A2150-A2152

Application: 07.5-10 GMC 2500-3500 HD (Non-Class)

13. With Headlights removed from the vehicle, remove the brackets off of the bottom of each by removing the 2 Torx screws. See Image Below.



Figure 7 - Headlight Clip Removal

14. Repeat step 12-13 for the other headlight
15. Your Truck is now ready for the installation of your New FAB FOURS BUMPER!



Installation Instructions

GMC Winch Bumper

Product Number: A2150-A2152

Application: 07.5-10 GMC 2500-3500 HD (Non-Classic)

IV. Lights and Wiring Installation

1. Remove headlights following procedure in owner's manual. On each side, tap into the three turn indicator wires using supplied tap connectors (reference the wiring diagram).
2. Connect supplied turn indicator wiring harnesses to factory wires using supplied tap connectors; See below for wire color guide.
3. Replace headlights in reverse order of removal.
4. Tap into OEM fog light harness using two supplied tap connectors.
5. Connect supplied fog lamp wiring harness to tap connectors following wire color guide below.
6. Run passenger side fog lamp supply wires across bottom of bumper and tap into Fab Fours driver side fog lamp wires.
7. Install turn indicators into the plastic light insert using three self-tapping screws as shown below:

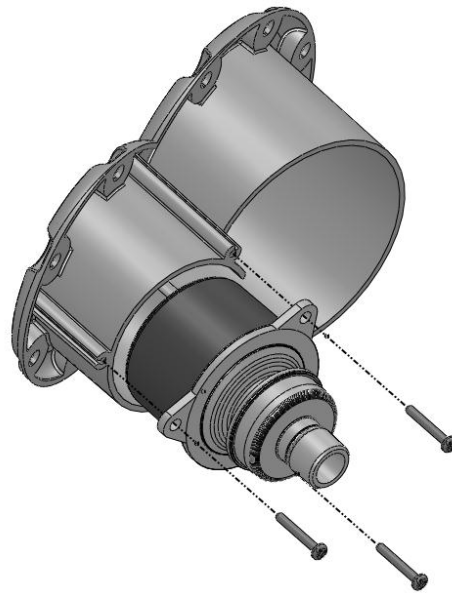

Figure 8 – Turn Signal Installation



Installation Instructions

GMC Winch Bumper

Product Number: A2150-A2152

Application: 07.5-10 GMC 2500-3500 HD (Non-Classic)

8. Install the light inserts with turn indicators into the cutout in the bumper. Use the $\frac{3}{4}$ " length $\frac{1}{4}$ " stainless steel button head, $\frac{1}{4}$ " washers and hex nuts to fasten the insert through the holes shown below:

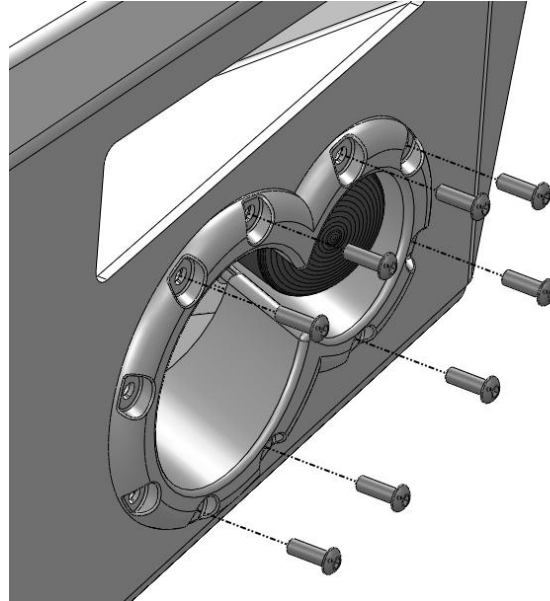

Figure 9 – Light Insert Installation

9. Install the Fab Fours fog lights onto the mounting brackets as shown below using the #8 button head screws, washers, and nylock hex nuts.

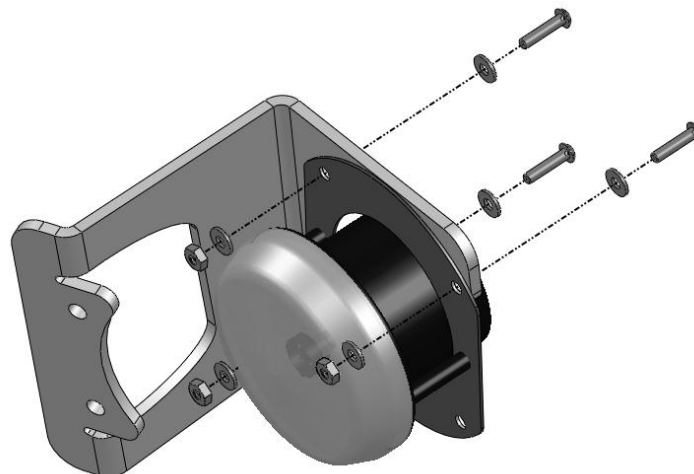

Figure 10 - Fog Light to Bracket Installation



Installation Instructions

GMC Winch Bumper

Product Number: A2150-A2152

Application: 07.5-10 GMC 2500-3500 HD (Non-Classic)

10. Install the fog light and bracket into the bumper using the remaining two holes available in the light insert. Use the 1-1/2" length 1/4" stainless steel button heads with 1/4" washers and nylock nuts:

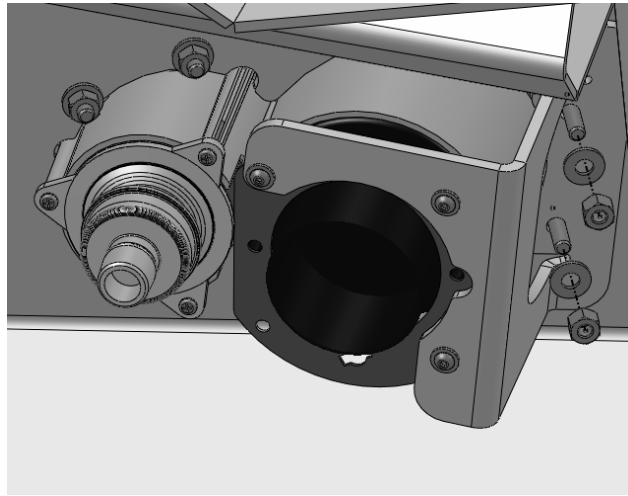
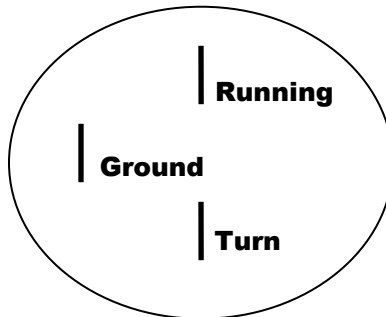

Figure 11 - Fog Light Installation

11. Repeat steps 7-10 for other side.

- Do not connect wiring harnesses to lights until bumper is installed.

Turn Indicator Connectors



TURN INDICATOR WIRE COLORS:

<u>WIRE</u>	<u>OEM COLOR</u>	<u>FAB FOURS COLOR</u>
Running	Brown	→ White
Turn	White/Green (Driver) White/Blue (Pass)	→ Red
Ground	Black	→ Green



Installation Instructions

GMC Winch Bumper

Product Number: A2150-A2152

Application: 07.5-10 GMC 2500-3500 HD (Non-Class)

V. Bumper Installation

- **Optional:** If installing winch and roller fairlead into bumper, do it at this time. Follow the winch manufacturer's instructions for installation. If you are installing a winch with a pulling capacity of 12,000 lbs. or greater, the front face mounting holes must be used.

If not installing a winch, a license plate may be installed onto the front face of the bumper using the provided 1/4" hardware.

1. Install intermediate mount onto the frame rail using the OEM bumper stud plates and nuts, and 1/2" x 1.5 bolts, washers, lock washers and nuts provided in the hardware kit. The offset portion of the bracket should face the outside of the truck. Be sure stud plates are re installed in the factory direction. **DO NOT FULLY TIGHTEN**, repeat for other side.

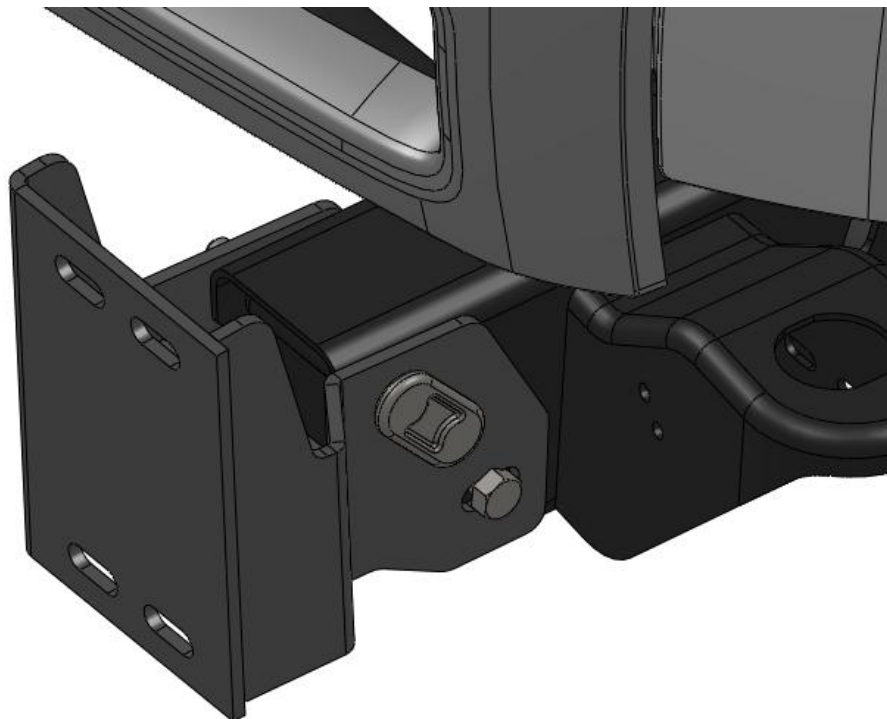

Figure 12 - Intermediate Bracket Installation



Installation Instructions

GMC Winch Bumper

Product Number: A2150-A2152

Application: 07.5-10 GMC 2500-3500 HD (Non-Classic)

2. Insert the provided stud plate assemblies through the back of the bumper mount face as shown below.

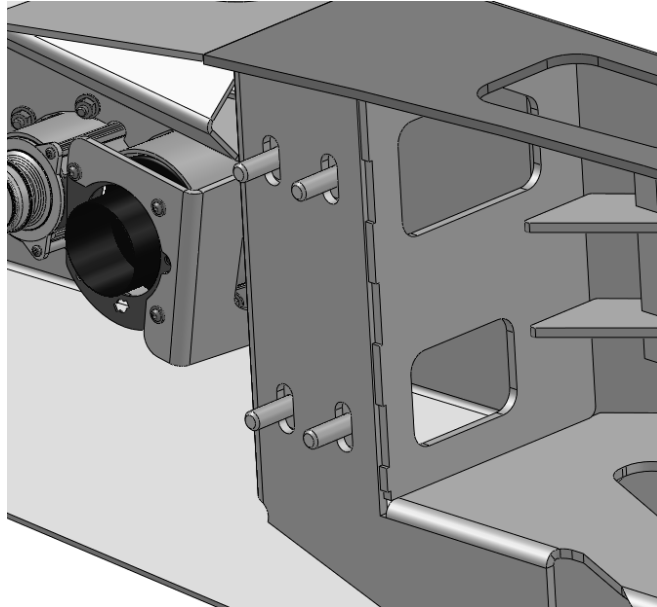

Figure 13 – Stud Plate Orientation

3. Lift the bumper and carefully insert the studs into the slots on the mounting brackets. With the bumper supported, install four nuts, washers, and lock washers per side onto the studs. **DO NOT FULLY TIGHTEN**

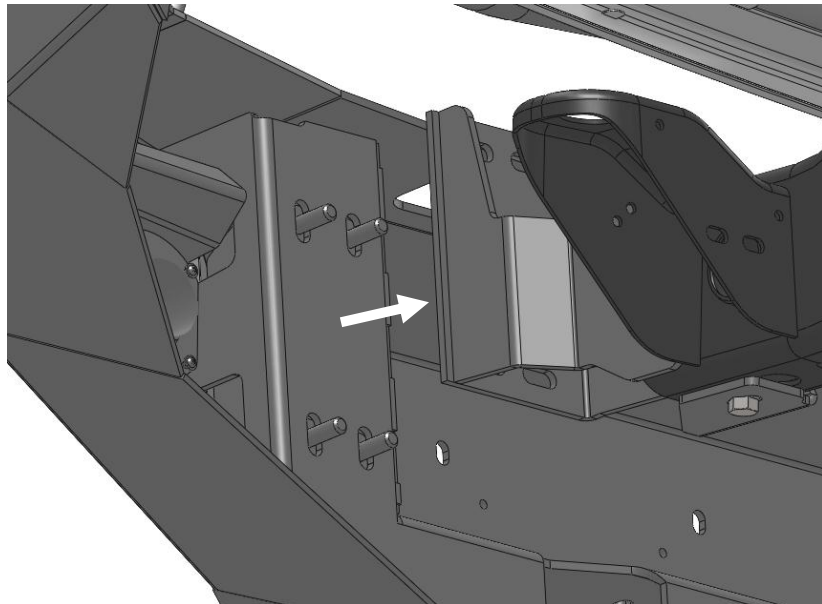

Figure 14 – Bumper Installation



Installation Instructions

GMC Winch Bumper

Product Number: A2150-A2152

Application: 07.5-10 GMC 2500-3500 HD (Non-Classic)

4. Adjust the bumper to achieve good visual alignment as follows:
 1. Adjust in/out bumper alignment with mounting bracket to frame hardware.
 2. Adjust up/down and left/right alignment with bumper to mounting bracket hardware
5. Tighten all fasteners fully; beginning with frame mounts. Then tighten all mount-to-bumper fasteners.
6. Connect wiring harnesses to lights as shown in wiring diagram.
7. Verify proper operation of lights. **Note:** Turn indicators should be dim during “running” condition and flash bright for turn.



Installation Instructions

GMC Winch Bumper

Product Number: A2150-A2152

Application: 07.5-10 GMC 2500-3500 HD (Non-Classic)

VI. Maintenance/Care

- Periodically check and tighten all fasteners.
- Stripped, fractured, or bent bolts or nuts need to be replaced.

VII. Contact Information

Fab Fours Inc.
1312 Camp Creek Rd.
Lancaster, SC 29720

Phone (866)-385-1905
Fax (866)-574-1424
Email Support@fabfours.com



More than expected... Better than expected