



Installation Instructions

2005+ Chevy/GMC 4500/5500 Winch Bumper

Product Number: A2350-A2352

Application: 05-Present Chevy Kodiak/GMC Top Kick 4500/5500

SAFETY

Your safety and the safety of others is very important.

- In order to help you make informed decisions about safety, we have provided installation instructions and other information.
- These instructions alert you to potential hazards that could hurt you or others.
- Please do a job safety analysis (JSA) before each task to identify potential hazards for your situation and remove/protect against them.
- You must use your own good judgment, and take your time.

Read and understand all safety precautions and instructions before installing this product.

THIS PRODUCT IS FOR OFFROAD USE ONLY. ALL LIABILITY FOR INSTALLATION AND USE RESTS WITH THE OWNER.

CARELESS INSTALLATION AND OPERATION CAN RESULT IN SERIOUS INJURY OR EQUIPMENT DAMAGE.

Injury hazard

Failure to observe these instructions could lead to severe injury or death.

- Always** remove jewelry and wear eye protection.
- Always** use extreme caution when jacking up a vehicle for work. Set emergency brake and use tire blocks. Locate and use the vehicle manufacturers designated lifting points. Use jack stands.
- Always** use appropriate and adequate care in lifting components into place.
- Always** insure components will remain secure during installation and operation.
- Always** wear safety glasses when installing this kit. A drilling operation will cause flying metal chips. Flying chips can cause serious eye injury.
- Always** use extreme caution when drilling on a vehicle. Thoroughly inspect the area to be drilled (on both sides of material) prior to drilling, and relocate any objects that may be damaged.
- Always** use extreme caution when cutting and trimming during fitting.
- Always** tighten all nuts and bolts securely per installation instructions.
- Always** route electrical cables carefully. Avoid moving parts, components that become hot and rough or sharp edges.
- Always** insulate and protect all exposed wiring and electrical terminals.
- Always** perform regular inspections and maintenance on mounts and related hardware.





Installation Instructions

2005+ Chevy/GMC 4500/5500 Winch Bumper

Product Number: A2350-A2352

Application: 05-Present Chevy Kodiak/GMC Top Kick 4500/5500

I. Overview

Congratulations on your purchase of the industries' best and most stylish Chevy Kodiak or GMC Top Kick Front Winch Bumper! This bumper has been **engineered** for strength while keeping the weight down. It can accept the Warn 16.5 winch... and look cool doing it.

This product has also been **engineered** to allow alignment in three directions plus "caster" so you will end up with a very professional fit.

Your bumper was designed in 3-D from digitized data, CNC laser cut, fabricated, and powder coated... all in the U.S.A.

Enjoy the fit and finish of a quality Chevy Kodiak or GMC Top Kick Front Winch Bumper from Fab Fours Inc!

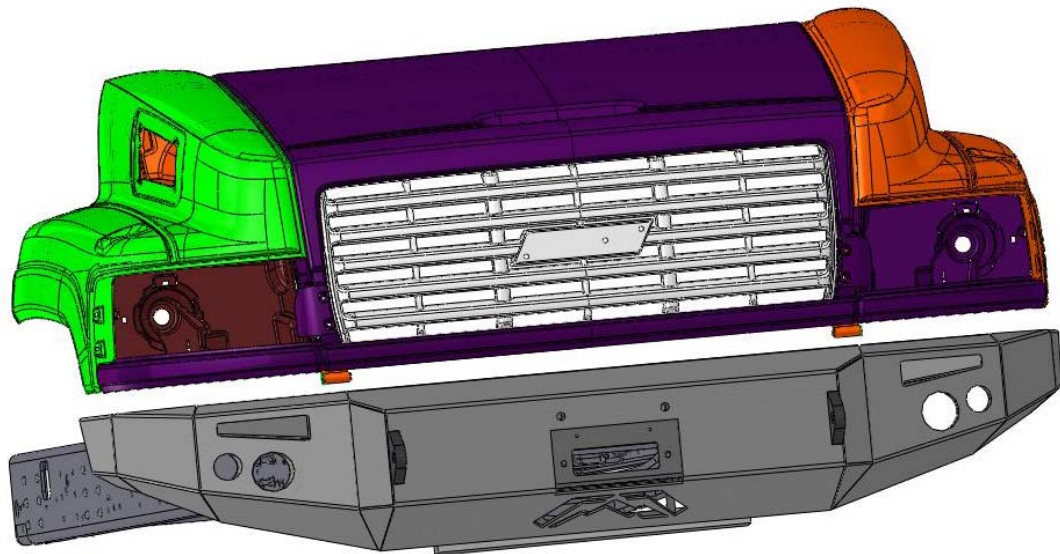



Installation Instructions

2005+ Chevy/GMC 4500/5500 Winch Bumper

Product Number: A2350-A2352

Application: 05-Present Chevy Kodiak/GMC Top Kick 4500/5500

II. Tools Required

- Socket Wrench with Extension
- 7/32", 3/4", 18mm, 24mm Sockets
- 5/32" & 1/8" Allen Wrench or Socket Drive
- 24mm, 3/8", 7/16", & 3/4" Box End Wrench
- Phillips Screwdriver
- Floor Jack and wood block.

III. Vehicle Preparation

A. Remove bolts(4 per Side) using a an 18mm socket attaching the OEM bumper to the OEM bumper mounts. Use another person to ensure that the bumper does not fall once the final bolt is removed. See Image Below





Installation Instructions

2005+ Chevy/GMC 4500/5500 Winch Bumper

Product Number: A2350-A2352

Application: 05-Present Chevy Kodiak/GMC Top Kick 4500/5500

B. Remove the bumper and set aside.

C. Remove the 4 large bolts and nuts from either side of the fram using a 24mm socket and wrench. This will allow the removal of the OEM Bumper mounts and the OEM Tow Hooks. DO NOT REMOVE THE 2 BOLTS COMING THROUGH THE BOTTOM OF THE FRAME, THESE WILL KEEP THE SPRING HANGERS IN PLACE UNTIL INSTALLATION IS COMPLETE! See Image Below.



D. Your Truck is now ready for the installation of your New FAB FOURS BUMPER!

IV. Lights and Wiring Installation

A. Connect supplied turn indicator wiring harnesses to tap connectors following wiring diagram located below; repeat for other side.

B. Install the supplied Fog Light Wiring Harness on the vehicle using its supplied instructions.





Installation Instructions

2005+ Chevy/GMC 4500/5500 Winch Bumper

Product Number: A2350-A2352

Application: 05-Present Chevy Kodiak/GMC Top Kick 4500/5500

C. Install turn indicators into outside bumper light pockets using three self-tapping screws per side. Note: verify that "TOP" lettering on turn indicator is facing top of bumper.

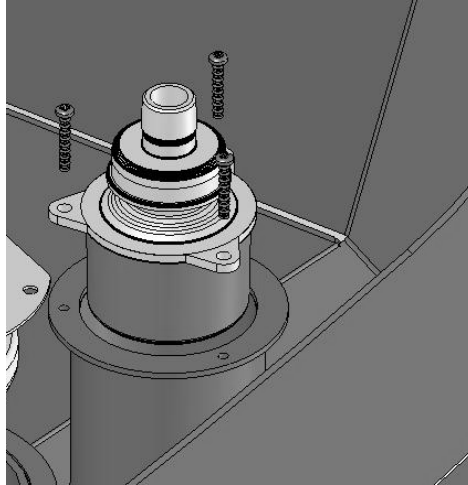

D. Install fog lamp brackets onto inner light pockets using two bolts and nuts per side and attach running light to bracket as shown using two bolts, washers, and nuts per side. Verify that light adjustment screw is facing downward before tightening fully.

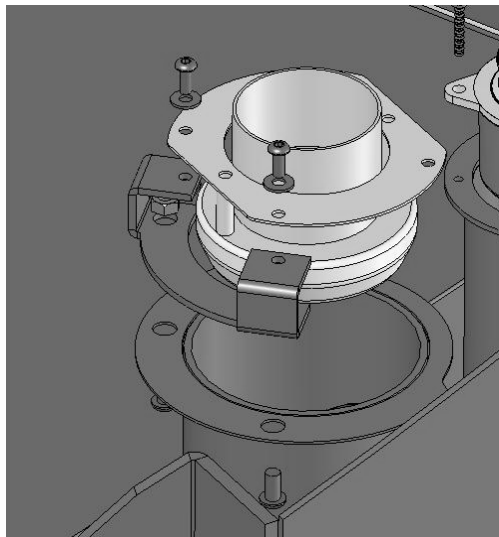



Installation Instructions

2005+ Chevy/GMC 4500/5500 Winch Bumper

Product Number: A2350-A2352

Application: 05-Present Chevy Kodiak/GMC Top Kick 4500/5500

V. Bumper Installation

NOTE: The Following Installation steps apply to the installation of the Bumper to the vehicle. **PLEASE READ THE ENTIRE MANUAL BEFORE ATTEMPTING INSTALLATION!** Ignoring these steps will increase your probability of scratching the vehicle during product Installation!

A. Remove the Bumper from the shipping carton. Lay all items out on a blanket to prevent damage to the powder coating.

B. OPTIONAL: If installing winch and roller fairlead (neither provided) into bumper, do it at this time. Bottom bolts (not provided) go through fairlead, then into winch. Thread 7/16" cap screws through hole in front bumper and into winch body.

C. NOTE: Winch should be bolted to **FRONT FACE** of the bumper in four places, and can be bolted to winch tray if so desired with two additional fasteners.

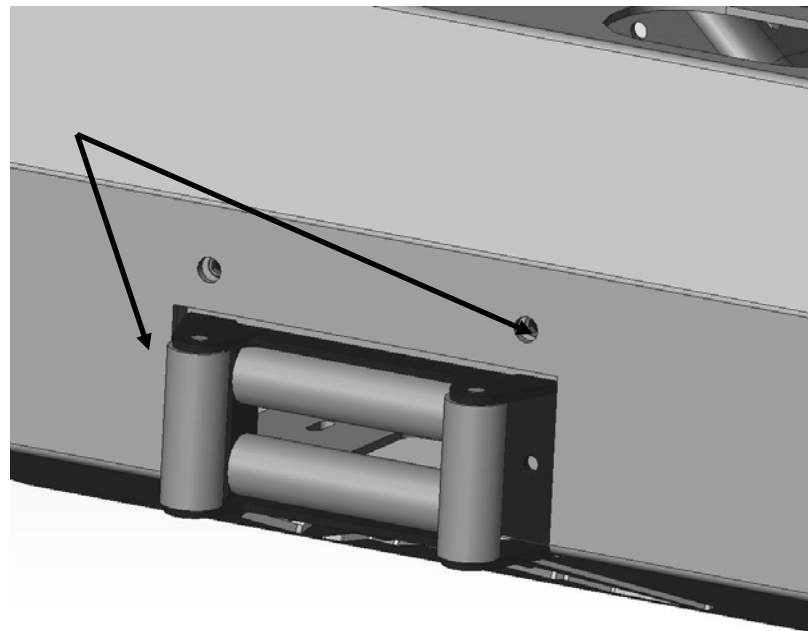



Installation Instructions

2005+ Chevy/GMC 4500/5500 Winch Bumper

Product Number: A2350-A2352

Application: 05-Present Chevy Kodiak/GMC Top Kick 4500/5500

D. Installed the supplied Bumper Frame mounts as shown below using the supplied and OEM hardware. Complete on each side. Do Not Fully tighten.



E. Install supplied 1/2"-13 Bolts and washer in through the back side of the bumper mount towers, by placing a flat washer onto the bolt and inserting it inot the bumper and out through the mount tower. The bolts can be held in place with the supplied retaining washers as shown below.

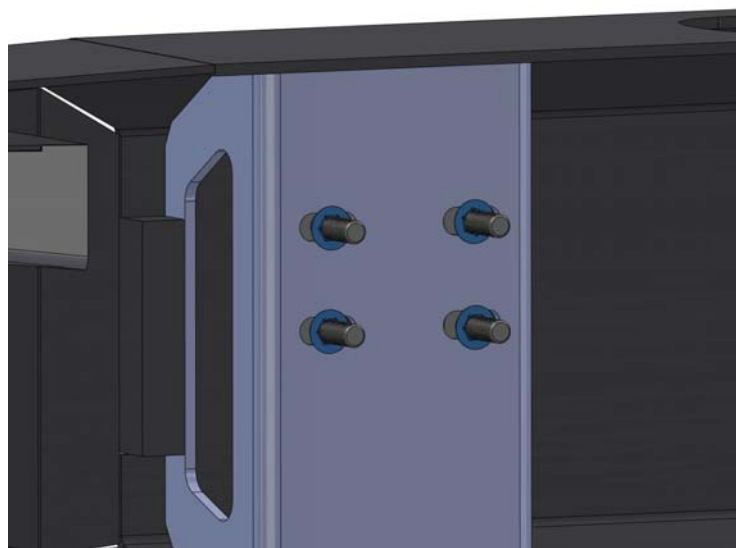



Installation Instructions

2005+ Chevy/GMC 4500/5500 Winch Bumper

Product Number: A2350-A2352

Application: 05-Present Chevy Kodiak/GMC Top Kick 4500/5500

F. Lift the bumper into place using a couple extra people and/or a floor jack for stability by guiding the bolts installed into the bumper in the previous step into the corresponding slots on the frame mounts installed on the frame. Secure it in place using the supplied washer, lock washer, and nuts. Do not fully tighten. See Image Below.

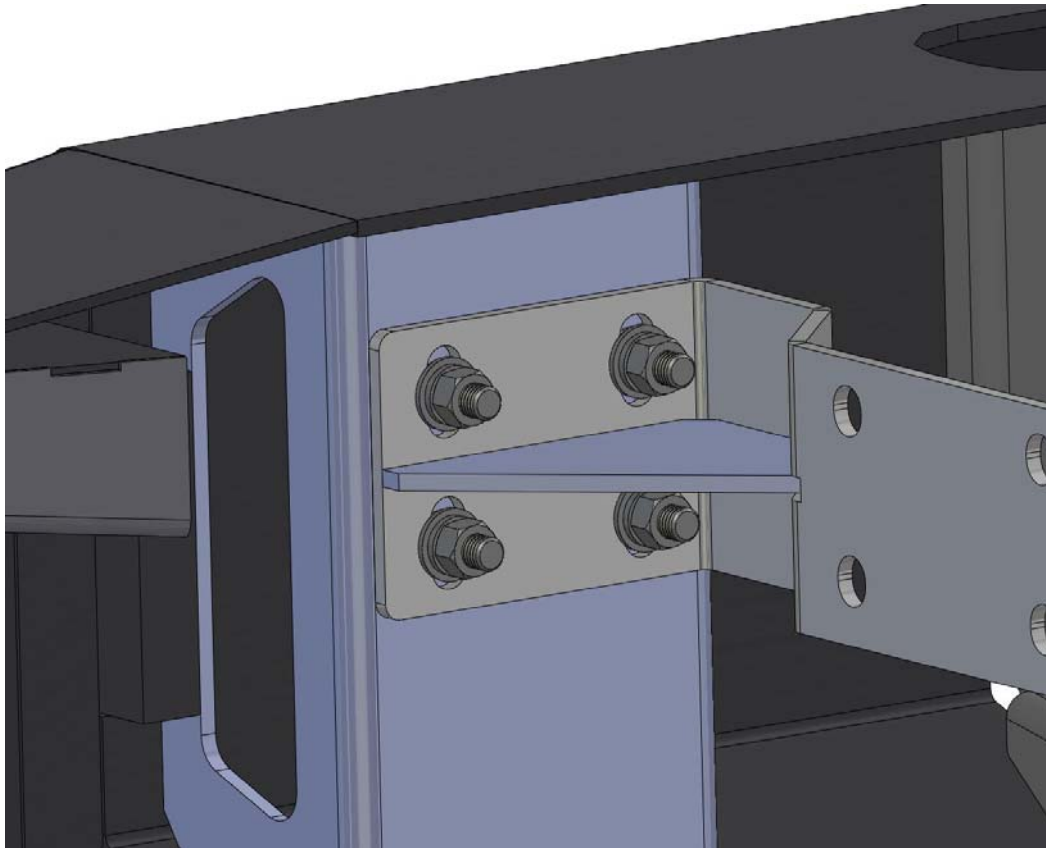

G. Adjust the bumper to achieve good visual alignment as follows:

- 1. Adjust “castor” with mounting bracket bolts.***
- 2. Adjust in/out and up/down with the intermediate mount bolts.***

H. Tighten all fasteners; beginning with frame mounts. Then tighten all mount-to-bumper fasteners.





Installation Instructions

2005+ Chevy/GMC 4500/5500 Winch Bumper

Product Number: A2350-A2352

Application: 05-Present Chevy Kodiak/GMC Top Kick 4500/5500

I. Connect wiring harnesses to lights as shown in wiring diagram.

J. Verify proper operation of lights. Note: Turn indicators should be dim during "running" condition and flash bright for turn.

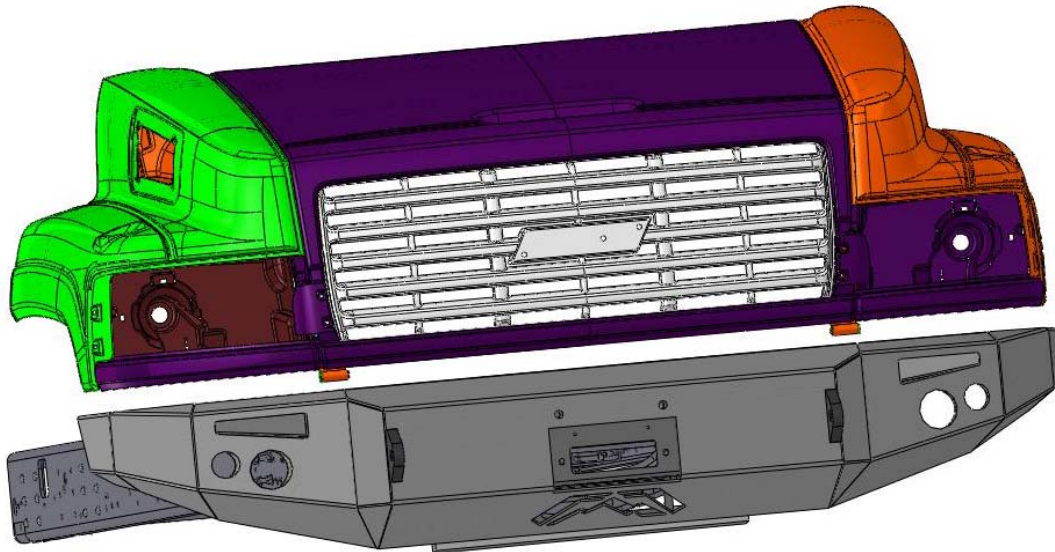



Installation Instructions

2005+ Chevy/GMC 4500/5500 Winch Bumper

Product Number: A2350-A2352

Application: 05-Present Chevy Kodiak/GMC Top Kick 4500/5500

VI. Wiring Diagram

Driver/Passenger Side Turn Indicator at Headlight

OEM (Running) Brown → White Fab Fours

OEM (Turn) Blue → Red Fab Fours

OEM (Ground) Black → Green Fab Fours

Fog Lamp

Follow Instructions supplied with the supplied fog wiring harness kit.

Note: Tap into Fab Fours driver side fog lamp harness to supply passenger side

Hella Turn Indicator Connectors

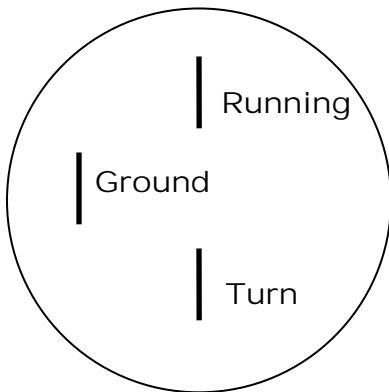



Installation Instructions

2005+ Chevy/GMC 4500/5500 Winch Bumper

Product Number: A2350-A2352

Application: 05-Present Chevy Kodiak/GMC Top Kick 4500/5500

VII. Maintenance/Care

- Periodically check and tighten all fasteners.
- Stripped, fractured, or bent bolts or nuts need to be replaced.

VIII. Contact Information

Fab Fours Inc.
10424 Rodney St.
Pineville, NC 28134

Phone (866)-385-1905
Fax (866)-574-1424
Email Support@fabfours.com



More than expected... Better than expected

