

**Read installation instructions completely before installing your Coil-Rite Air Helper Springs.**

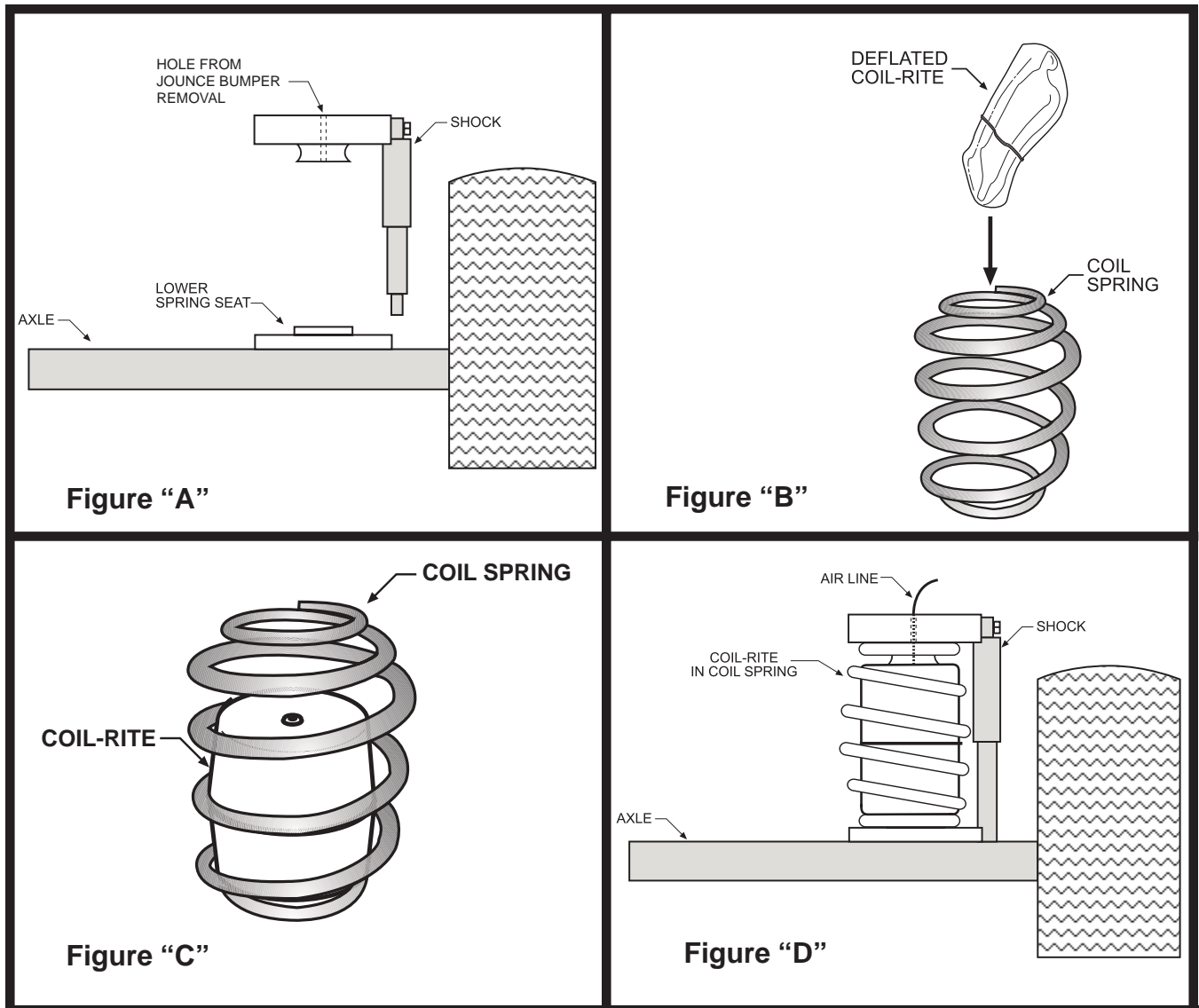

PARTS	QTY.	OPERATING PRESSURES
AIR SPRINGS	6020	2
18' AIR LINE	1	1
THERMAL SLEEVE	2	2
NYLON TIE	6	6
INFLATION VALVE	2	2
5/16" FLAT WASHER	4	4
		MINMIUM (UNLOADED): 5 PSI
		MAX (LOADED): 35 PSI

### Step 1 – Vehicle Preparation

Remove the negative battery cable. With the vehicle on a solid level surface, chock the front wheels. Using a jack rated for the weight of your vehicle, raise the wheels off the ground. Lower the vehicle frame onto jack stands rated for the vehicle weight, making sure the suspension is fully extended. (Do not use wood or concrete blocks to support the vehicle.)

### Step 2 – Remove the Coil Spring

Place a jack under the axle on the left side of the vehicle. Remove the lower bolt from the shock absorber. Lower the axle until the coil spring can be removed. **Caution: DO NOT put tension or strain on the flexible brake line.** Remove the jounce bumper located in the coil spring using a T-50 Torx bit. The jounce bumper will not be reused. **See Figure “A”.**

### Step 3 – Install the Air Spring

Deflate the Coil-Rite air spring and place it inside the coil spring with the air fitting pointing up. (**Figure “B” & “C”**). Cut the air line into to equal lengths, making sure the ends are cut as squarely as possible (a “sawing” motion with a razor blade is preferred). Route the air line through the hole in the center of the upper spring seat from the jounce bumper removal, and out through an access hole in the frame. Push one end of the air line into the fitting on the air spring as far as possible.

### Step 4 – Reinstall the Coil Spring

Reinstall the coil spring with the Coil-Rite on to the vehicle. Pass the excess air line through the access hole in the frame. Reattach the bottom of the shock absorber and tighten the bolt to manufacturers’ specifications. **See Figure “D”.**

**For installation on the right side, repeat Steps 2 through 4.**

### Step 5 – Install the Inflation Valves

Choose a location to mount the inflation valves. This should be a protected location such as the rear bumper or trunk floor but maintain accessibility for the air chuck. Drill two 5/16" holes and pass the valves through and tighten the nuts. **See Figure “F”.**

### Step 6 – Route the Air Line

Route the air line from the air springs to the inflation valves (**Figure “E”**). Avoid any sharp edges or hot surfaces as well as sharp angles. The air line can be secured with the provided nylon ties. Cut off any excess air line using the method mentioned above and push the end as far as possible into the inflation valve.

### Step 7 – Inflate and Test

Inflate the air springs to recommended maximum operating pressure (see page 1 for operating pressures). With a soap and water solution, check for air leaks around the fittings and valve core. Inflate and deflate in small increments to find the ideal riding pressure for your vehicle.

### Step 8 – Completion

Raise the vehicle, remove the jack stands, and lower the vehicle to the ground. Reattach the battery cable.

