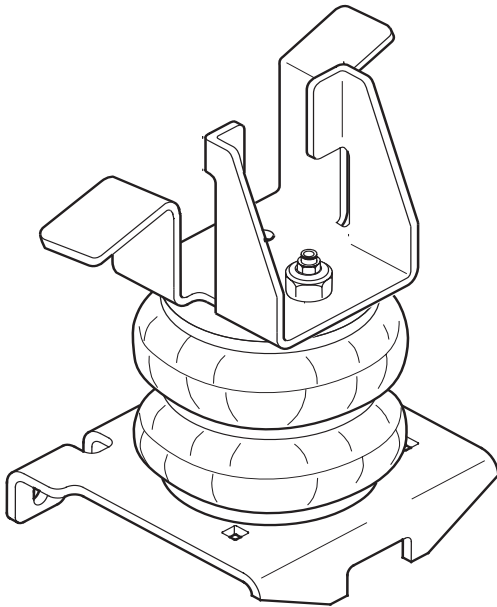

TO BE USED ON A PICKUP TRUCK ONLY**WARNING:**

Do not inflate this assembly when it is unrestricted. The assembly must be restricted by the suspension or other adequate structure. Do not inflate beyond 100 psi. Improper use or over inflation may cause property damage or severe personal injury.

INSTALLATION INSTRUCTIONS

Congratulations - your new air helper springs are quality products capable of improving the handling and comfort of your vehicle. As with all products, proper installation is the key to obtaining all of the benefits your kit is capable of delivering. Please take a few minutes to read through the instructions to identify the components and learn where and how they are used. It is a good idea to start by comparing the parts in your kit with the parts list below.

The heart of the air spring kit is, of course, the air helper springs. Remember that the air helper springs must flex and expand during operation, so be sure that there is enough clearance to do so without rubbing against any other part of the vehicle.

Be sure to take all applicable safety precautions during the installation of the kit. The instructions listed in this brochure and the illustrations all show the right or passenger's side of the vehicle. To install the left side assembly simply follow the same procedures.

This kit includes inflation valves and air lines for each air spring. This will allow you to compensate for unbalanced loads. If you would rather have a single inflation valve system to provide equal pressure to both air springs, your dealer can supply the optional "T" fitting.

IMPORTANT!

For your safety and to prevent possible damage to your vehicle, do not exceed the maximum load recommended by the vehicle manufacturer (GVWR). Although your Air Helper Springs are rated at a maximum inflation pressure of 100 psi, this pressure may allow you to carry too great a load on some vehicles. It is best to have your vehicle weighed once it is completely loaded and compare that weight to the maximum allowed. Check your vehicle owner's manual or data plate on driver side door for maximum loads listed for your vehicle.

When inflating your air helper springs, add air pressure in small quantities, checking pressure frequently during inflation. The air spring requires much less air volume than a tire and, therefore, inflates much quicker.

PARTS LIST

AIR SPRING	6401	2
LEFT UPPER BRACKET	5719	1
RIGHT UPPER BRACKET	5718	1
LOWER BRACKET	5720	2
BRACKET CLAMP	5433	2
INSERT	5721	2
HEAT SHIELD	1004	1
BAIL CLAMP	3429	2
AIR LINE TUBING	0937	1

BOLT PACK (A21-760-2528)

INFLATION VALVE	3032	2
MALE FITTING	3046	2
3/8"-16 X 2" FLAT HEAD BOLT		2
3/8"-16 X 5/8" FLAT HEAD BOLT		2
3/8"-16 X 7" CARRIAGE BOLT		4
3/4"-16 HEX NUT		2
3/8"-16 FLANGE NUT		8
3/8" FLAT WASHER		4
3/4" INTERNAL TOOTH LOCK WASHER		2
5/16" FLAT WASHER		4
THERMAL SLEEVE		2
NYLON TIE WRAP		7
CAUTION TAG		2

FIGURE "A"

NOTE: All illustrations are of the left or driver's side of the truck. Refer to step 3 for proper lower bracket alignment.

NOTE: THE JOUNCE BUMPER CUP STAYS ON THE FRAME AFTER THE JOUNCE BUMPER IS REMOVED. THE UPPER BRACKET FITS AROUND THE JOUNCE BUMPER CUP.

NOTE: TALL LEG FACES TOWARDS FRONT OF VEHICLE!



The **INSERT** must be pushed into the jounce bumper cup and then twisted into place to capture the flanges on the inside of the cup. See Figure "B".

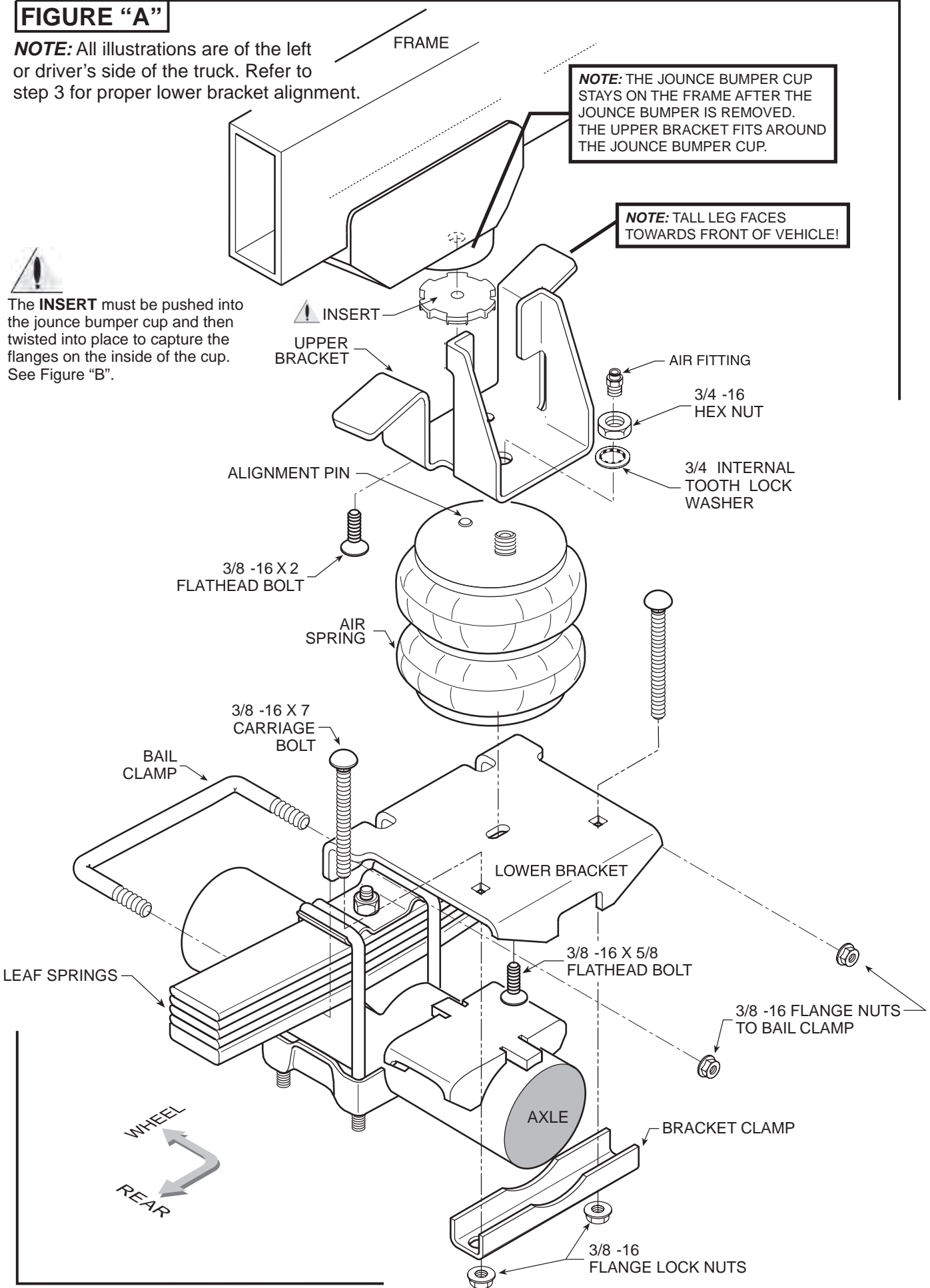

NOTE:

Please read through this manual completely before installing the air spring kit to your vehicle. A heat shield is required on the exhaust side of the vehicle as noted in Step 4. If your truck has an aftermarket dual exhaust system, you may have to order an extra heat shield.

STEP 1—PREPARE THE VEHICLE

Remove the jounce bumper located under the frame rail. The jounce bumpers will pull out of the jounce bumper welded to the frame

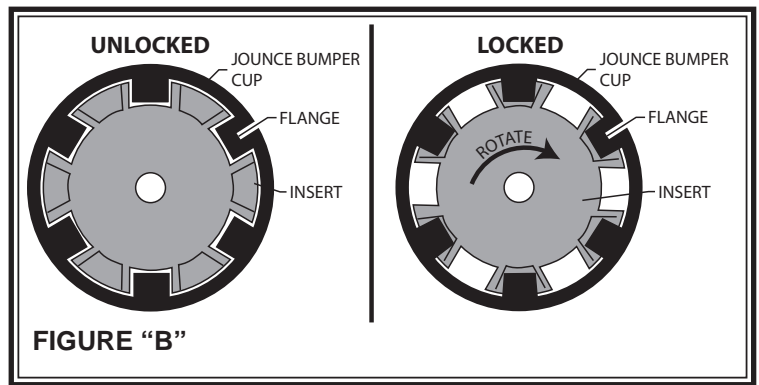

STEP 2—PRE-ASSEMBLE THE KIT

Place the carriage bolts into the square holes of the lower bracket and then fasten the lower bracket to the air helper spring using a 3/8"-16 x 5/8" flat head bolt. See Figure "A".

STEP 3—INSTALLING THE ASSEMBLY TO THE VEHICLE

Place the Insert into the jounce bumper cup. Align the cut-outs of the insert with the flanges inside the cup. Turn the insert so the recessed portion of the insert captures the flanges. See Figure "B". Place the right upper bracket onto the frame and secure it to the frame using a 3/8"-16 x 2" flat head bolt threaded into the insert. Select one air helper spring from your kit and insert the large stud into the large hole, and the alignment pin in the small hole. Use whichever hole provides the best alignment. Secure the air spring to the bracket using a 3/4"-16 hex nut and 3/4" internal tooth lock washer. See Figure "A". Install the male fitting into the air spring. Tighten the air fitting securely to engage the orange thread sealant. Install the bail clamp under the leaf springs from the outside of the leaf stack into the holes in the legs of the lower bracket. Secure the bail clamp to the lower bracket with the 3/8"-16 flange nuts and draw the lower bracket against the leaf stack. See Figure "C". Attach the lower bracket to the axle using the bracket clamp and the 3/8"-16 flange nuts, see Figure "A". Once the assembly is in place, you must have a minimum of 1/2" clearance around the air spring for proper operation.

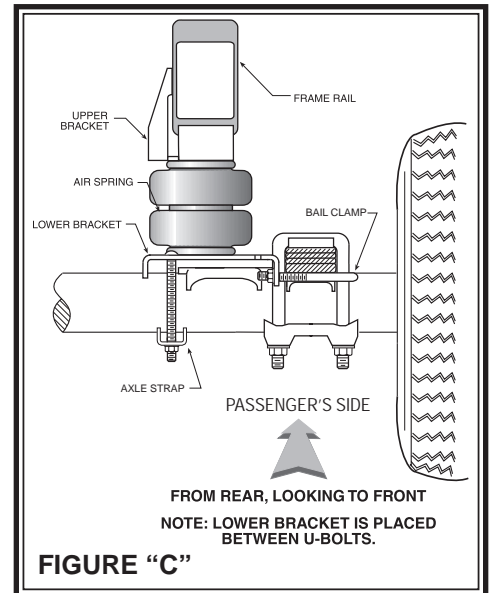

Note: The use of a heat shield is required on the passenger's side of the vehicle, see Figure "D". The heat shield will mount between the upper bracket and the air helper spring. Bend the heat shield so it will fall halfway between the air helper spring and the closest point on the exhaust. Be sure that the heat shield will not contact any other component as the suspension compresses (i.e. brake lines, shock absorbers, lower bracket assembly).

STEP 4—INSTALLATION OF THE DRIVER'S SIDE ASSEMBLY

Follow steps 1-3 for assembly and installation of the driver's side.

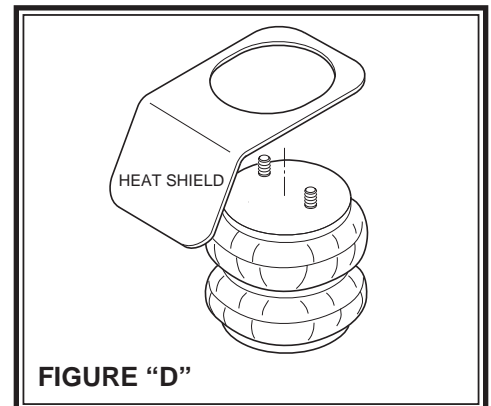

STEP 5—INSTALL THE AIR LINE AND INFLATION VALVE

Uncoil the airline tubing and cut it into two equal lengths. **DO NOT FOLD OR KINK THE AIRLINE TUBING.** Try to make the cut as square as possible. Insert one end of the airline tubing into the air fitting installed in the top of the air helper spring. Push the airline tubing into the fitting as far as possible.

Select a location on the vehicle for the air inflation valves. The location can be on the bumper or the body of the vehicle, as long as it is in a protected location so the valve will not be damaged, but maintain accessibility for an air chuck, see Figure "E". Drill a 5/16" hole and install the air inflation valve using two 5/16" flat washers per valve as supports see Figure "F".

Run the airline tubing from the air helper spring to the valve, routing it to avoid direct heat from the engine, exhaust pipe, and away from sharp edges. Thermal sleeves have been provided for these conditions. The airline tubing should not be bent or curved sharply as it may buckle. Secure the airline tubing in place with the nylon ties provided. Push the end of the airline tubing into the inflation valve as illustrated see Figure "F".

STEP 6— CHECK THE AIR SYSTEM

Once the inflation valves are installed, inflate the air helper springs to 70 psi and check the fittings for air leaks. Using a spray bottle, apply a solution of soap and water to the fittings. If a leak is detected at a airline tubing connection then check to make sure that the airline is cut as square as possible and that it is pushed completely into the fitting. The airline tubing can easily be removed from the fittings by exhausting all the pressure in the air springs and then pushing the collar towards the body of the fitting and then, with a gentle pull, remove the airline tubing. If a leak is detected where the air fitting screws into the spring, screw the air fitting into the air spring one additional turn or until the leak stops. Reinstall the tubing and reinflate the air springs and check for leaks as noted above.

This now completes the installation. Install the wheels and torque the lug nuts to the manufacturer's specification. Raise the vehicle by the axle and remove the jack stands. Lower the vehicle to the ground. Reattach the negative battery cable and remove the wheel chocks from the front wheels. Before proceeding, check once again to be sure you have proper clearance around the air springs. With a load on your vehicle and the air helper springs inflated, you must have at least 1/2" clearance around the air springs. As a general rule, the air helper springs will support approximately 50 lbs. of load for each psi of inflation pressure (per pair). For example, 50 psi of inflation pressure will support a load of 2500 lbs. per pair of air helper springs. **FOR BEST RIDE** use only enough air pressure in the air helper springs to level the vehicle when viewed from the side (front to rear). This amount will vary depending on the load, location of load, condition of existing suspension and personal preference.

NOTE:

Too much air pressure in the air helper springs will result in a firmer ride, while too little air pressure will allow the air helper spring to bottom out over rough conditions, and will not provide the improvement in handling that is possible. **TO PREVENT POSSIBLE DAMAGE MAINTAIN A MINIMUM OF 5 psi IN THE AIR HELPER SPRINGS AT ALL TIMES.**

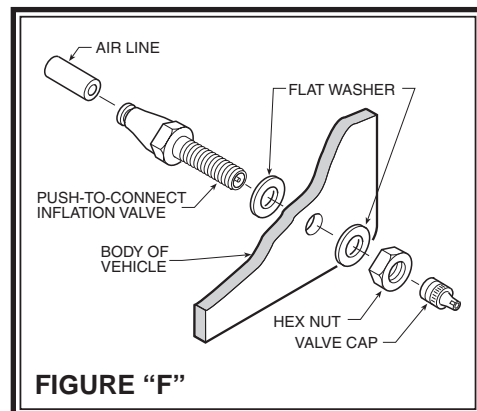
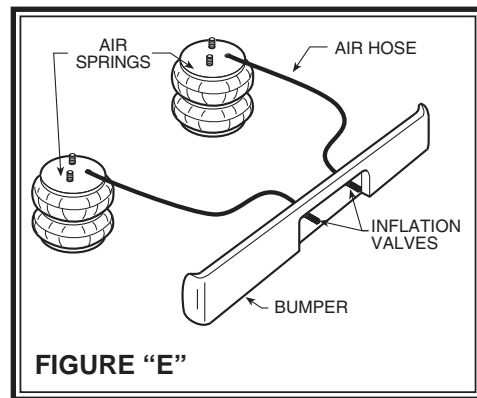

NOTE:

MIN PRESSURE	5 PSI
MAX PRESSURE (LOADED)	100 PSI

RIDE-RITE
SPORT-RITE COIL-RITE
AIR HELPER SPRINGS

www.ride-rite.com