



INSTALLATION INSTRUCTIONS

Congratulations – your new Work-Rite load assists are quality products capable of improving the handling and comfort of your vehicle while under load. As with all products, proper installation is the key to obtaining all of the benefits your kit is capable of delivering. Please take a few minutes to read through the instructions to identify the components and learn where and how they are used. It is a good idea to start by comparing the parts in your kit with the parts list below.

***NOTE: IF ANY PARTS ARE MISSING FROM THE KIT,
PLEASE CALL 1-800-888-0650.
PLEASE DO NOT CALL OR RETURN THE KIT TO THE DEALER.***

Be sure to take all applicable safety precautions during the installation of the kit. The instructions listed in this brochure and the illustrations all show the left, or driver's side of the vehicle. To install the right side assembly simply follow the same procedures.

STEP 1 – PREPARE THE VEHICLE

With the vehicle on a solid, level surface chock the front wheels. Remove the negative battery cable. Remove the jounce bumpers located under the frame rail, by prying them out of the jounce bumper cup. The jounce bumpers will not be re-used with this kit but the bolts will be reused.

STEP 2 – PREASSEMBLY

Select one Work-Rite load assist and one face plate for the kit. Attach the Work-Rite to the face using the 3/8"-16 x 1" hex bolt, flat washer, and lock nut. **See Figure "A"**.

NOTE: An optional spacer may be installed to engage the Work-Rite sooner when a load is applied. To install, place between the Work-Rite and the face plate. If the spacers are installed, use the 3/8"-16 x 2" bolts instead of the 3/8"-16 x 1" bolts. There should be 1/4" to 3/8" between the Work-Rite and the jounce stop. See Figure "B".

STEP 3 – INSTALLING THE ASSEMBLY ONTO THE VEHICLE

Select one spacer ring from your kit and place it around the jounce bumper cup. Place the assembly against the bottom of the jounce bumper cup and align the holes in the face plate with the holes in the spacer ring. Place the clamp rings on top of the spacer ring, aligning the holes. Insert the 3/8"-16 x 1-1/2" flat head bolts into the tapered holes on the face plate and secure to the clamp ring with the flange lock nuts. **See Figures "A" & "B"**.

STEP 4 – FINISH UP

Remove the wheel chocks and reconnect the battery cable. Now you're finished and ready to put your Work-Rite to use!

PARTS LIST

WORK-RITE LOADASSISTS	1258	2	3/8"-16 X 1" HEX BOLT	2
FACE PLATE	5641	2	3/8"-16 X 2" HEX BOLT	2
SPACER RING	5642	2	3/8"-16 X 1-1/2" FLAT HEAD BOLT	12
CLAMP RING	5643	4	3/8"-16 FLANGE LOCK NUT	14
1/2" SPACER	0013	2	3/8" FLAT WASHERS	2
1/4" SPACER	5229	2		

Figure "A"

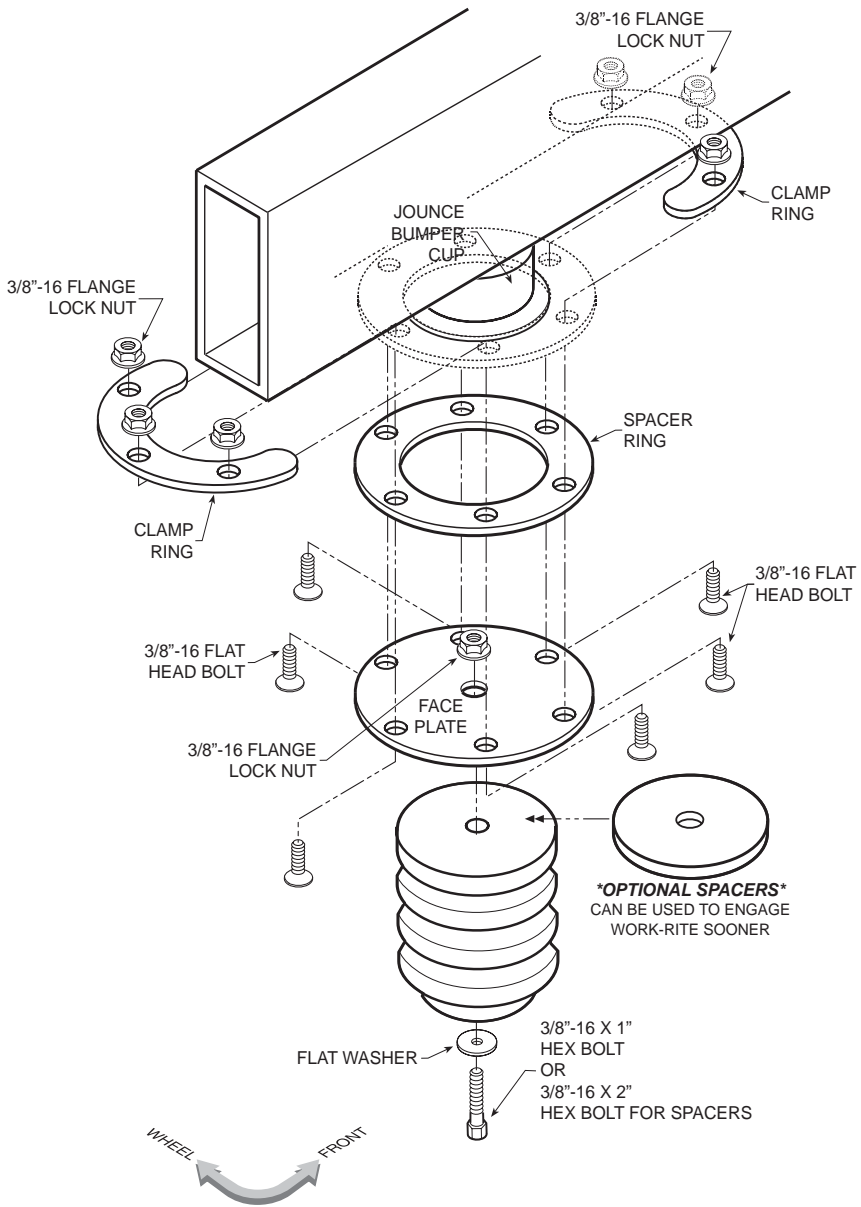

Figure "B"

