



INSTALLATION INSTRUCTIONS

Congratulations – your new Work-Rite load assists are quality products capable of improving the handling and comfort of your vehicle while under load. As with all products, proper installation is the key to obtaining all of the benefits your kit is capable of delivering. Please take a few minutes to read through the instructions to identify the components and learn where and how they are used. It is a good idea to start by comparing the parts in your kit with the parts list below.

***NOTE: IF ANY PARTS ARE MISSING FROM THE KIT,
PLEASE CALL 1-800-888-0650.
PLEASE DO NOT CALL OR RETURN THE KIT TO THE DEALER.***

Be sure to take all applicable safety precautions during the installation of the kit. The instructions listed in this brochure and the illustrations all show the left, or driver's side of the vehicle. To install the right side assembly simply follow the same procedures.

STEP 1 – PREPARE THE VEHICLE

With the vehicle on a solid, level surface chock the front wheels. Remove the negative battery cable. Remove the jounce bumpers located under the frame rail. The jounce bumpers, bolts, and nuts will not be re-used with this kit.

STEP 2 – PRE-ASSEMBLE THE KIT

Insert the frame brace into the frame, being careful not to pinch any of the existing lines inside the frame rail. Slide the upper bracket onto the frame rail and frame brace making sure that all the holes line up. **See Figures "A" & "B"**. Use the holes in the bracket as a template, mark and drill the holes in the frame rail. **Before drilling the holes make sure all electrical, brake and fuel lines are cleared from the path of the drill. It is recommended to place a thin piece of wood between the frame rail and the existing lines.** After drilling the holes, attach the upper bracket with the 3/8"-16 x 4" hex bolts.

NOTE: An optional spacer may be installed to engage the Work-Rite sooner when a load is applied. To install, place between the Work-Rite and the upper bracket. If 1 spacer is installed, use the 3/8"-16 x 1-1/2" bolts, or the 2" bolts for 2 spacers. There should be 1/4" to 3/8" between the Work-Rite and the axle. See Figure "B".

STEP 3 – INSTALLING THE ASSEMBLY ON THE VEHICLE

Attach the Work-Rite to the upper bracket using 3/8"-16 x 1" hex bolts, large flat washers, and flange lock nuts inserted through the bottom of the Work-Rite and into the hole in the upper bracket. **See Figure "A"**.

STEP 4 – FINISH UP

Remove the wheel chocks and reconnect the battery cable. Now you're finished and ready to put your Work-Rite to use!

PARTS LIST

WORK-RITE (8622 KIT)	1258	2	3/8"-16 X 1" HEX BOLT	2
WORK-RITE (8623 KIT)	1259	2	3/8"-16 X 1-1/2" HEX BOLT	2
WORK-RITE (8624 KIT)	1260	2	3/8"-16 X 2" HEX BOLT	2
UPPER BRACKET	5647	2	3/8"-16 X 4" HEX BOLT	4
FRAME BRACE	5180	2	3/8"-16 FLANGE LOCK NUT	6
OPTIONAL SPACERS	0013	4	3/8" LARGE FLAT WASHERS	2

Figure "A"

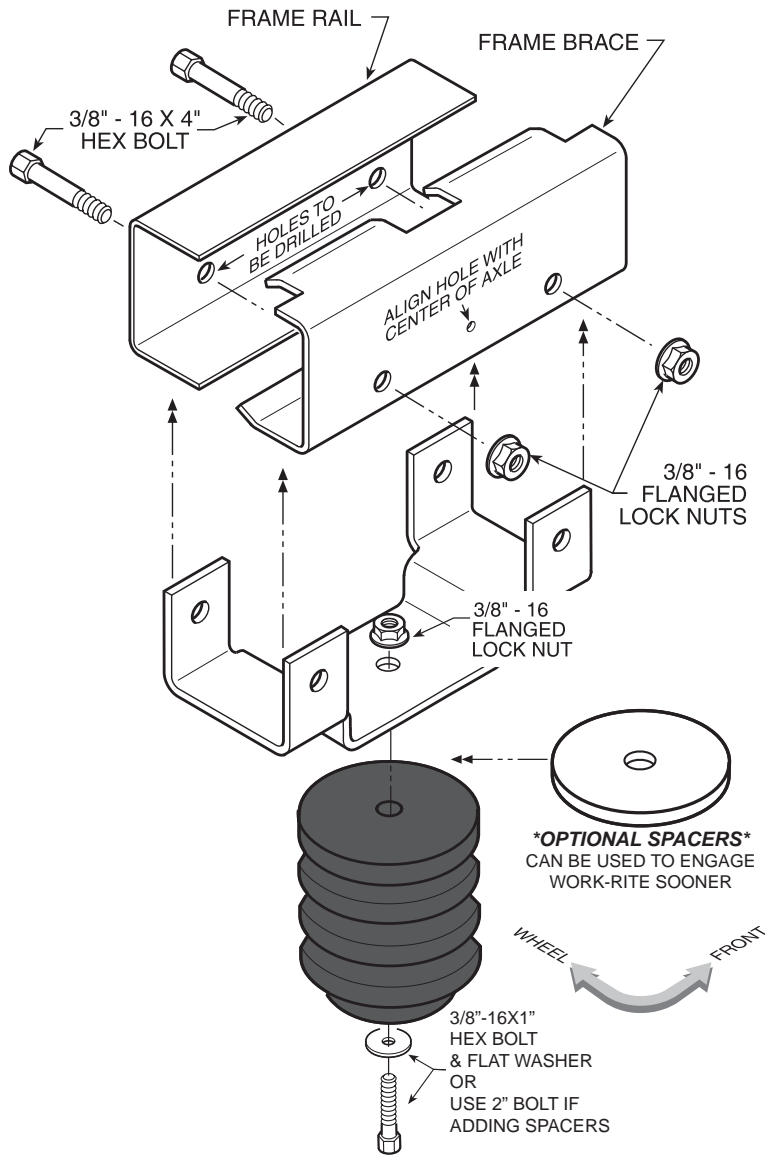

Figure "B"

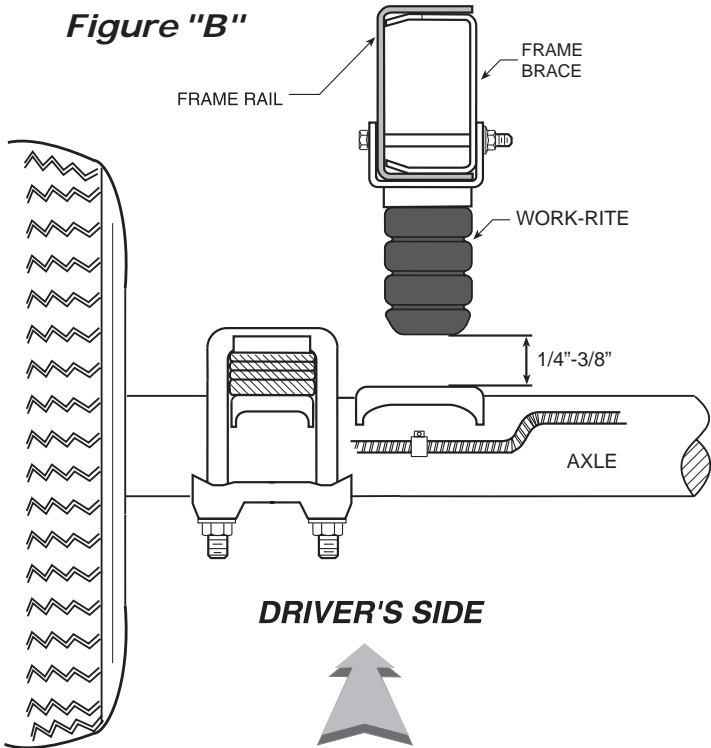

Figure "C"

