



INSTRUCTION MANUAL

CAT-BACK DUAL EXTREME EXHAUST

SILVERADO/SIERRA 1500 TRUCK
STANDARD CAB, LONG BED 4.3L, 4.8L, 5.3L 2WD
CLASSIC STANDARD CAB, LONG BED 4.3L - 4.8L 2WD

PART # 5001

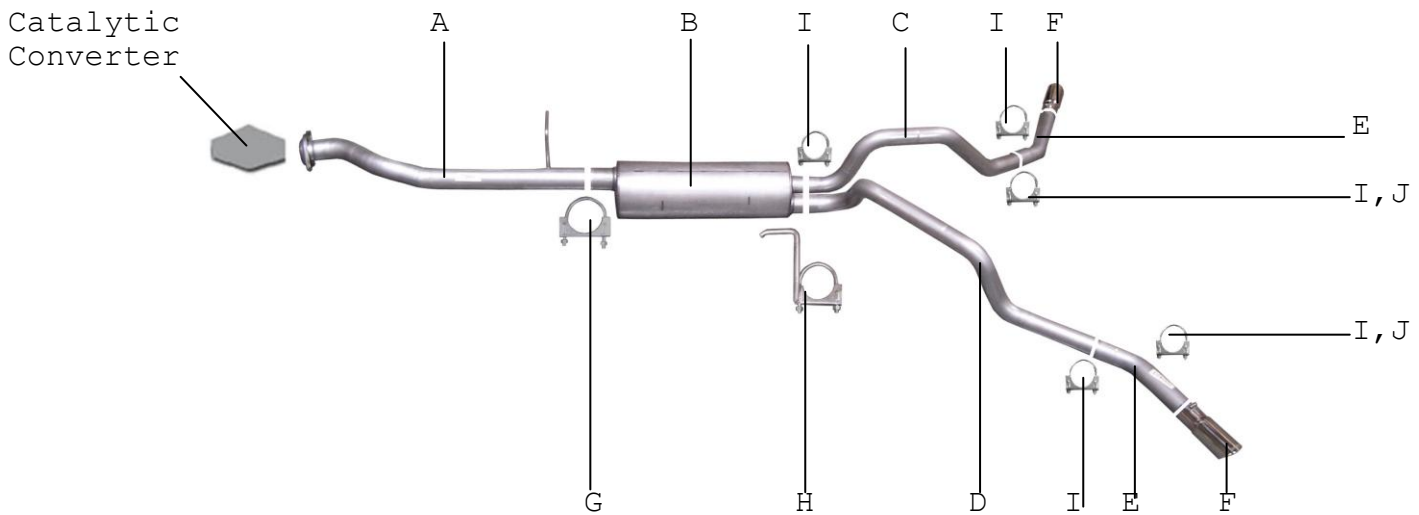

ITEM	PART #	QUANTITY	DESCRIPTION
A	700463	1	3" HEADPIPE W/ FLANGE # GP-115
B	758250	1	SUPERFLOW MUFFLER
C	700183	1	2-1/2" PASS. SIDE TAILPIPE
D	700184	1	2-1/2" DRIVERSIDE TAILPIPE
E	700423	2	2-1/2" EXIT PIPE
F	500374	2	3-1/2" STAINLESS TIP
G	OHD300	1	3" CLAMP
H	4192	1	REAR MUFFLER HANGER
I	5757	5	2-1/2" CLAMP
J	08269	2	10" METAL HANGER
J	BO-101	2	BOLT KIT FOR 10" HANGER
K	ZIP	2	ZIP TIE
L	4137	1	SPARE TIRE BRACKET

Thank you for purchasing our Gibson exhaust system for your vehicle. If you need further assistance, please do not hesitate to call our technical dept at (800) 528-3044 Monday through Friday, 8:00 am to 5:00 pm.

EXHAUST INSTALLATION # 5001

When installing this exhaust system make sure to use proper safety precautions. Use jack stands when under the truck, set parking brake, block tires and use safety glasses and gloves.

DO NOT WORK WITH HOT PIPES!

SUGGESTED TOOLS:

1/2", 9/16" 15 mm Wrench & Socket, WD-40, Hacksaw, Jack Stand



Lay out the exhaust on the floor so it looks like the drawing and compare parts with manual. To remove the stock exhaust remove it from the 2-bolt flange located in front of the new muffler. **Do not discard factory hardware, you will re-use it.** Leave all rubber grommets in place. Use WD-40 to aid in removal of exhaust and the hangers. Cut off tailpipe.



Install the passenger side over axle tailpipe # C to the muffler 1-1/2" to 2". Use clamp # I to secure tailpipe to muffler.



Install head pipe # A onto your existing stock front pipe and bolt using your factory bolts. Use a jack stand to support the converter. Insert welded hanger into rubber grommet.



Install metal hangers # J on both exit pipes into holes located approximately 22" from the rear of the frame. Use the 3rd hole from the top of the hanger.

Install the driver side over axle tailpipe # D into the muffler 1-1/2" to 2". Use clamp # H to secure to the muffler. Do not tighten. Use clamp # I into to hold up the hanger. Do not tighten.

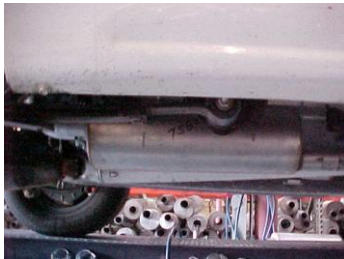

Install muffler # B on to head pipe 1-1/2" to 2" with the louvers facing towards the converter. Use a jack stand to support the muffler. Use clamp #G to secure the muffler to the head pipe. Do not tighten.



Next, install the exit pipes # E. Use clamps # I to secure to the tailpipes, and attach hangers' # J.



Install rear muffler hanger # H on to the driver side outlet of the muffler. Insert hanger into rubber grommet.



Install stainless steel tips. Clamp down. When you have everything in place, firmly tighten all bolts and clamps down securely. To clean stainless steel tips, use stainless steel cleaner and a Scotch Brite pad. Use zip ties to tie away brake lines.

MAKE SURE YOU HAVE A 1" CLEARANCE ON ALL RUBBER BRAKE LINES, SHOCK BOOTS, FUEL LINES, TIRES, ETC..