

INSTALLATION INSTRUCTIONS

CAT-BACK EXTREME DUAL EXHAUST

TAHOE/YUKON 5.3L 2/4WD 4DR

PART #5570

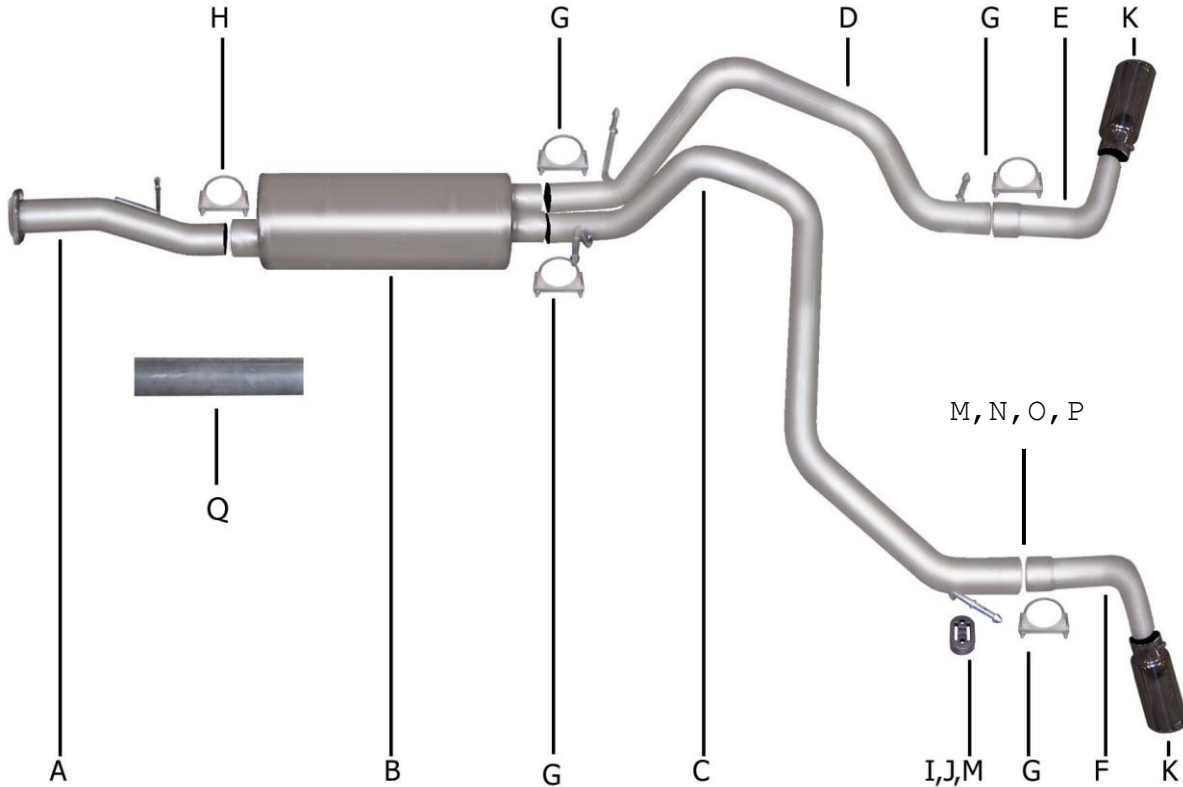

ITEM	PART #	QUANTITY	DESCRIPTION
A	700776	1	3" HEADPIPE W/GP-115 FLANGE
B	758300	1	SUPERFLOW MUFFLER
C	700931	1	2¼" DRIVER SIDE TAILPIPE
D	700932	1	2¼" PASSENGER SIDE TAILPIPE
E	700784	1	2¼" PASSENGER SIDE EXIT PIPE
F	700785	1	2¼" DRIVER SIDE EXIT PIPE
G	5756	4	2¼" CLAMP
H	OHD300	1	3" CLAMP
I	4262	1	DRIVER SIDE REAR HANGER
J	BO-1032	1	BOLT KIT FOR HANGER
K	500395	2	3½" STAINLESS TIP
L	ZIP	2	ZIP TIES
M	4240	2	RUBBER GROMMET
N	40109	1	DRIVER SIDE REAR HANGER
O	40110	1	HANGER CLAMP
P	BO-101	1	BOLT KIT
Q	701089	1	3" HEADPIPE W/WELDED HANGER (09 MODELS WITH BALL SEAT)

Thank you for purchasing our Gibson exhaust system for your vehicle. If you need further assistance, please do not hesitate to call our technical dept at (800) 528-3044 Monday through Friday, 8:00 am to 5:00 pm.

INSTALLATION INSTRUCTIONS #5570

CAREFULLY READ INSTRUCTIONS BEFORE STARTING INSTALLATION

When installing this exhaust system make sure to use proper safety precautions. Use jack stands when working under the vehicle, set parking brake, block tires and use safety glasses and gloves. Allow exhaust to cool before attempting installation. Severe injury or burns could occur if safety measures are not taken.

SUGGESTED TOOLS: 1/2", 9/16" 15mm wrenches & sockets, WD-40, hacksaw, jack stands.



1. Disconnect the negative battery cable before removal of OEM exhaust. This will allow the computer to reset and recognize the new exhaust. Lay out the exhaust on the floor so it looks like the drawing and compare parts with manual.

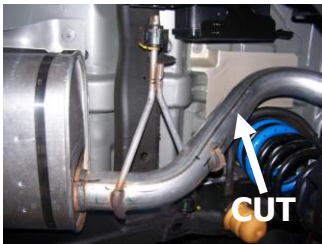

2. To remove the stock exhaust, unbolt it from the two bolt flange in front of the muffler. Do not disguard you will re-use bolts. Disengage the welded hangers using WD-40 from the OEM rubber grommets. Do not damage or remove the rubber grommets as you will reuse them to mount your new system. Now, cut off tailpipe before and after rear axle for removal.

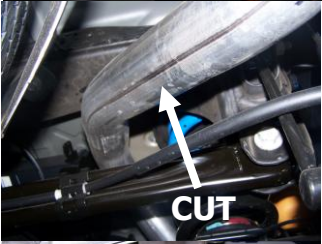

3. 2009 models you will use pipe #Q as your headpipe. You will re-use your factory clamp.

Bolt head pipe #A onto your existing stock front pipe re-using stock nuts/bolts. Use a jack stand to support the converter. Insert welded hanger into rubber grommet. DO NOT TIGHTEN.

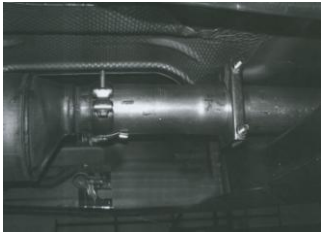

4. Install muffler #B onto head pipe 1 1/2"-2" with the louvers facing towards the converter. Use a jack stand to support the muffler. Use clamp #H to secure the muffler to the headpipe. DO NOT TIGHTEN. Muffler inlet is looking into the louvers.

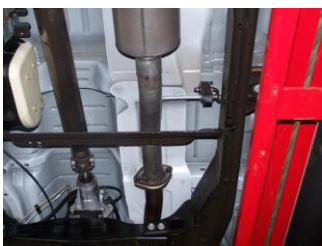

5. Install passenger side tailpipe #D to the muffler 1 1/2"-2". Use clamp #G to secure tailpipe to muffler. DO NOT TIGHTEN. Insert welded hangers into rubber grommet.



6. Install driver side rear hanger #I into hole located on cross member in front of spare tire.



7. Install driver side tailpipe #C to the muffler 1 1/2"-2". Use clamp #G to secure tailpipe to muffler. DO NOT TIGHTEN. Insert welded hangers into rubber grommets.



8. Install the exit pipes #E and #F. Use clamp #H to secure exit pipes to tailpipes. DO NOT TIGHTEN.



9. Install stainless steel tips. Clamp down. When you have everything in place, firmly tighten all bolts and clamps down securely. Use stainless steel cleaner and a Scotch Brite pad weekly to prevent tip from discoloration. Inspect all fasteners after 25-50 miles of operation and re-tighten as necessary.



GIBSON EXHAUST systems are designed on a factory stock vehicle. Any aftermarket products installed could increase the sound levels of this Exhaust.

Make sure there is a 1" clearance from ALL rubber brake lines, shock boots, fuel lines, tires, etc to prevent heat related damage or fire.