



P/N 12601HKR SUPER COMPETITION ENGINE SWAP MOUNTS 1971-74 Monza/Vega Chevy V-8 (Small Block)

Thank you for making HOOKER HEADERS your choice in a high-performance exhaust system. Extensive dyno/track testing has enabled HOOKER to offer the most advanced design in exhaust systems. The installation, while not complex, will take a certain amount of time. However, the additional horsepower and improved performance will more than justify your efforts. Proper installation and maintenance will ensure long life and maximum performance from your HOOKER HEADER exhaust system.

NOTE: Vehicles using manual transmissions will need to modify the clutch cable bracket.

WARNING! Breaking in an engine with ceramic-coated headers **WILL** result in damage to the coating and will **VOID** all warranties. Ceramic-coated headers require several heat cycles to fully cure before they will withstand extreme heat. HOOKER recommends using a cast-iron exhaust manifold or an old header to break in new engines to avoid coating damage.

BEFORE STARTING

Your vehicle must be raised a minimum of 36 inches. A floor hoist is ideal. If no hoist is available, we strongly urge the use of axle stands as a safety measure. **CAUTION!** YOUR CAR SHOULD NOT BE SUPPORTED ON A BUMPER JACK.

INSTALLATION PROCEDURE – PLEASE READ CAREFULLY

1. Remove the stock engine, transmission, and rear end.
2. Attach the front mount (left and right brackets) to the engine furnished with 3/8" x 3" bolts, using the original front mount holes (tap 3/8"-16 if necessary) and the top water pump holes. See **Figure A**.
3. Remove the oil pan from your engine and modify so that it will clear the steering. See **Figure B**.
4. Remove the idler arm and install the right side mount (use the stock bolts and nuts to tighten). Weld along the rear gusset. See **Figure C**.
5. Assemble the engine and transmission (do not include starter at this time).
6. Lower the engine and transmission into place. Mark the firewall and transmission tunnel for proper clearance around transmission. Remove the engine and transmission. Modify the firewall and transmission tunnel, as necessary.
7. Position the engine and transmission. Make sure the transmission is centered on the chassis. Now, install the transmission mount per instructions enclosed with the transmission mount kit (possibly Chevrolet P/N 3945476). This mount will accommodate 350 or 400 turbo hydromatic and 4 speed. An alternate transmission mount can be used with 350 turbo hydromatic (1967-72 Camaro Chevrolet P/N 3895831). See **Figure D**.
8. Remove the engine and transmission. Modify and install the starter. See **Figure E**.

NOTE: Be certain to use a short starter, such as Chevrolet P/N 1108381 - late model that bolts to the block.

9. Lower the motor into position. Make certain everything is centered. Install the transmission.
 10. Install the right side motor mount assembly. Do not tighten at this time. Use the rectangular washer plate to back up the lower rubber mount and insert the 9/16" bolt.
 11. Again, check to make sure everything is centered. Install the left side motor mount. See **Figure F**.
- NOTE:** Left side **MUST** be welded **AFTER** the engine is installed. Right side mount weld is optional (down sides).
12. Install Hooker Headers P/N 2129HKR (made for this installation). Consult instruction sheet included with that header for proper procedure.
 13. Check that headers have sufficient clearance. Relocate engine slightly, if necessary. Tighten all bolts.
 14. If your car uses an automatic transmission, use a floor mounted shifter that uses a cable.
 15. If your Vega uses a manual transmission, you will need to purchase a clutch cable bracket and a clutch cross-shaft.
 16. If the heater is to be used, a short water pump heater hose nipple will be required to clear the front engine mount properly.
 17. We recommend these additional changes: (a) a narrowed late model rear end, (b) heavy duty springs or A/C spacers in the front to support the additional weight, (c) a larger fan (check fan blades/sway bar clearance,

When finished, give your vehicle a test drive, checking carefully for any new noises. After several days of driving, retighten all the bolts.

Any questions? Please contact Technical Service: 1-866-GOOLLEY or 270-781-9741. For online help, please refer to the website: www.holley.com.

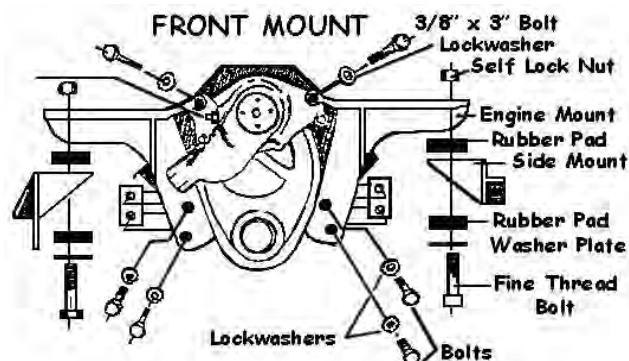

Figure A

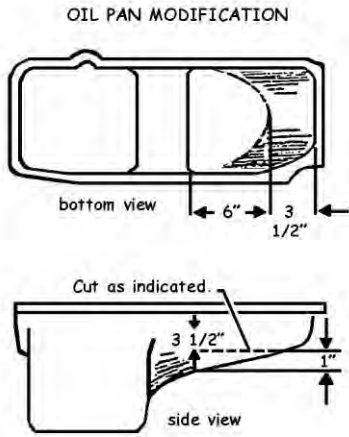
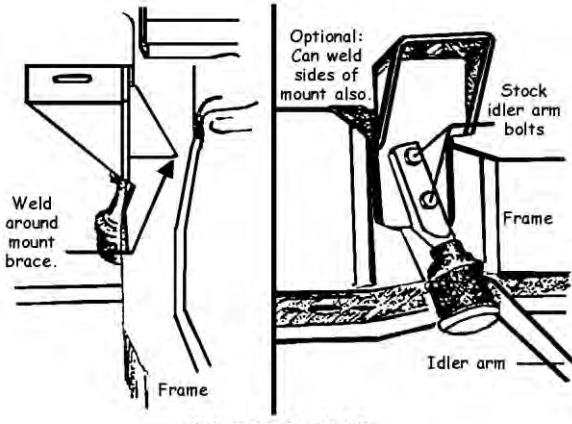
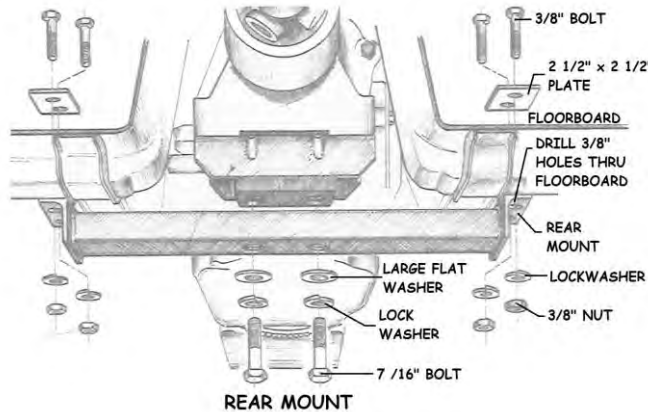

Figure B



RIGHT SIDE MOUNT

Figure C



REAR MOUNT

Figure D

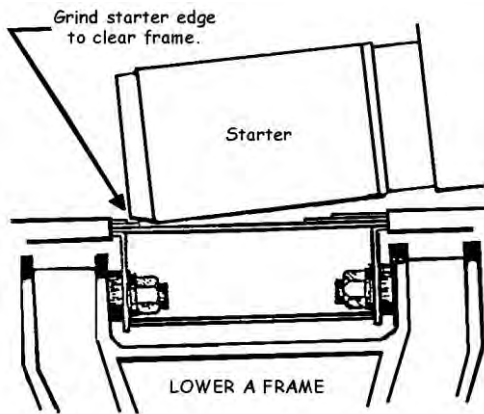
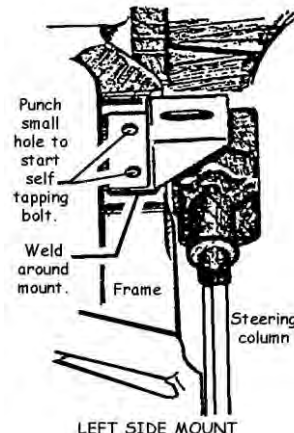

Figure E



LEFT SIDE MOUNT

Figure F

LIMITATION OF LIABILITY – DISCLAIMER:

The regulation of emissions production, noise levels, and safety standards is undertaken by the federal government, each of the fifty state legislatures, and by many local municipalities, towns, and counties. HOOKER makes no warranties of merchantability, of fitness for particular purpose, or that its products are approved for general use, or that its products comply with laws, regulations, or ordinances in the state where they may be sold to the ultimate purchaser, the consumer. Unless expressly stated to the contrary in the catalog, instruction sheet, or price list, the entire risk as to the conformity of any company product in any such state and as to repair should the product prove to be defective or non-conforming, is on the retail purchaser, the buyer, the ultimate consumer, of such product and it is not upon the seller, distributor, or manufacturer.

In this connection, the retail purchaser, the buyer, the ultimate consumer assumes the burden of the entire cost of any and all necessary service, alterations, or repair.

THE FOREGOING STATEMENT LIMITS THE LIABILITY OF THE MANUFACTURER.

California vehicle code, sections 27156 AND 38391, prohibits the advertising, offering for sale, or installation of any device, which modifies a vehicle's emission control system, unless exempted, unless otherwise noted. HOOKER Headers have not received an exemption from these code sections and are to legal for sale or use in California on vehicles originally equipped with catalytic converters, it is illegal, except for racing vehicles, which may never be driven upon a highway. To remove or otherwise render inoperative any emission control device on the regulated motor vehicles – check catalog listings to ensure proper application in the other 49 states, unless otherwise noted, HOOKER Headers are not legal for pollution-controlled motor vehicles, except for racing vehicles, which may never be used upon a highway and are not intended or applicable for highway use.

12601HKR

Date: 2-1-11