

instruction sheet

HOLLEY THROTTLE BODY INJECTION MODEL 3210 AND 3200 (PRO-JECTION)

TYPICAL VIEW — 3200/3210

The exploded view shown is typical of the model T.B.I. this kit will service, the view may differ slightly from the actual T.B.I. being renewed.

NOMENCLATURE

REF. NO.	REF. NO.
1. Air Cleaner Stud	14. Fuel Line Fitting Washer
2. Injector Clamp	15. Fuel Meter Body Screw
3. Injector Caps & Connector Assembly	16. Fuel Meter Body
4. Fuel Injector	17. Fuel Meter Body Gasket
5. O-Ring	18. Fast Idle Solenoid
6. Injector Flange	19. Idle Adjusting Screw
7. O-Ring	20. Idle Adjusting Screw Spring
8. Fuel Meter Cover Screw	21. Throttle Position Sensor Screw & L.W.
9. Fuel Meter Cover	22. Throttle Position Sensor Retainer
10. Pressure Regulator Spring	23. Throttle Position Sensor
11. Pressure Regulator Spring	24. Idle Air Control Valve
12. Pressure Regulator Diaphragm Assembly	25. Idle Air Control Valve Gasket
13. Fuel Line Fitting	26. Flange Gasket

REMOVAL

REMOVAL

Model 3200 — Leave engine off for at least one hour after running to relieve fuel pressure. Follow normal service procedures to remove the T.B.I. assembly from the intake manifold.

Model 3210 — Remove fuse marked "fuel pump" from fuse block in passenger compartment. Start engine and allow to run until fuel supply remaining in lines is consumed. When engine stalls, engage starter for three seconds to assure all pressure is relieved. Do not replace the fuse or turn the key to the run position until the installation is complete. Follow normal service procedures to remove the T.B.I. assembly from the intake manifold.

DISASSEMBLY

Rest the T.B.I. assembly on a repair stand to avoid damage to the throttle plate and electrical connections during renew procedures. Use exploded view as a guide, and follow the numerical sequence in general to disassemble unit far enough to permit cleaning and inspection.

CAUTION: The pressure regulator contains a large spring under heavy compression which, if accidentally released, could cause personal injury. To disassemble remove two pressure regulator cover screws opposite each other. Reinstall them three turns, then slowly remove the other two screws evenly to relieve spring tension. While holding regulator cover, remove the remaining screws.

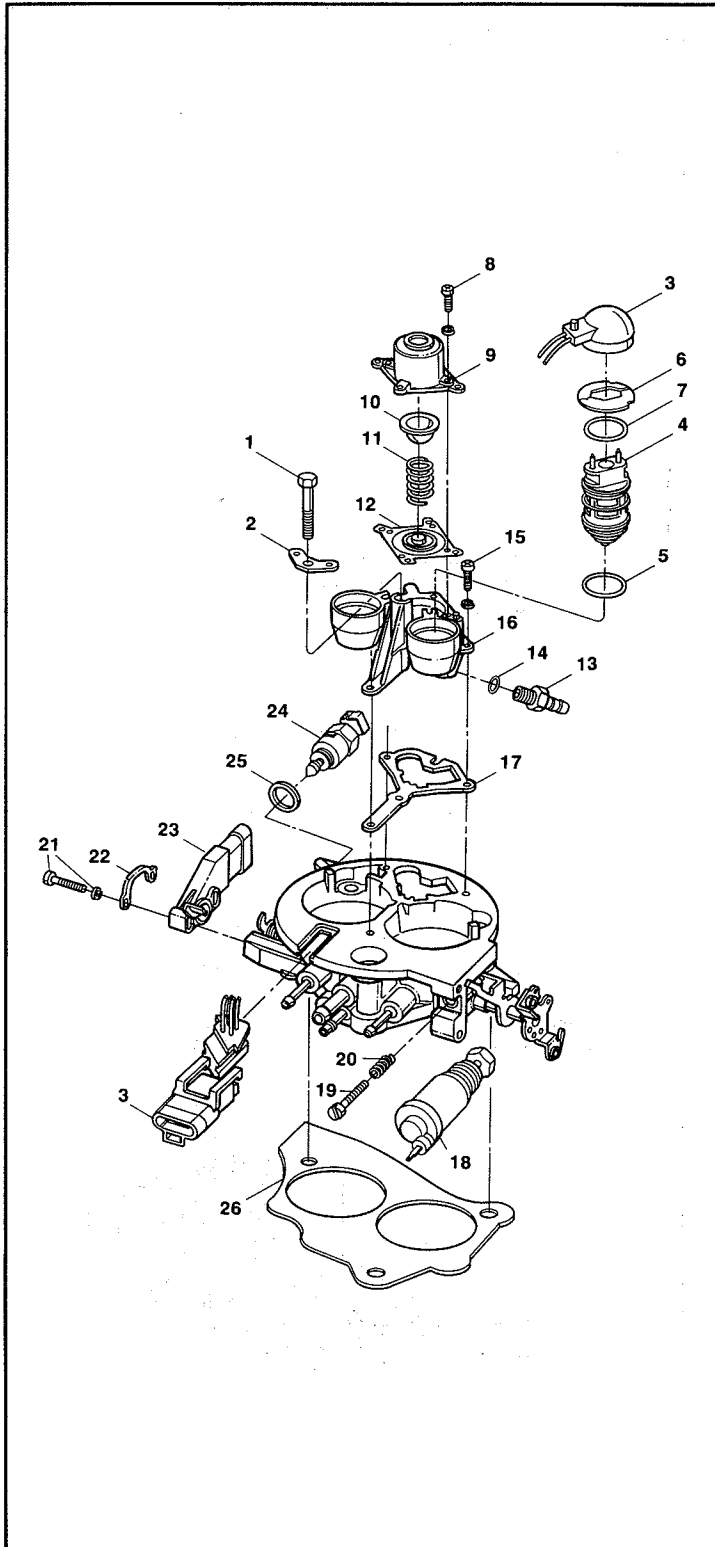

FUEL INJECTORS — Use care in removing injectors, as the electrical connectors, injector fuel filter and nozzle are easily damaged.

CLEANING

Cleaning must be done with throttle body disassembled. Soak parts long enough to soften and remove all foreign material. Use a carburetor solvent, lacquer thinner or denatured alcohol. Make certain the throttle body is free of all hard carbon deposits. Wash off in suitable solvent. Blow out all passages in castings with compressed air and check carefully to insure thorough cleaning of obscure areas.

CAUTION: Do not soak parts containing rubber or plastic material. Injectors should never be immersed in cleaner, as damage may result.

REASSEMBLY

Reassemble in reverse order of disassembly. Note special instructions and follow outline in making adjustments.

Manually operate throttle lever, checking for binding or other malfunction. Any binding or interference could cause throttle to stick during operation and could result in loss of throttle control (or uncontrolled engine speed).

Check fuel component connections for leaks, and correct immediately.

SPECIAL INSTRUCTIONS

Fuel Injector — Lubricate "O" rings with automatic transmission fluid before installing.

Pressure Regulator Diaphragm — when installing diaphragm, hold diaphragm in place by inserting the two installation pins through two bolt holes opposite each

other. After pressure regulator cover is on with two screws started, remove the installation pins.

Fast Idle Adjustment — For model 3200, adjust fast idle solenoid by turning hex head. Adjust fast idle to vehicle manufacturer's specifications.

Ecu Adjustment — For model 3200, it may be necessary to readjust the computer. Refer to your Pro-Projection installation manual for the proper procedures.

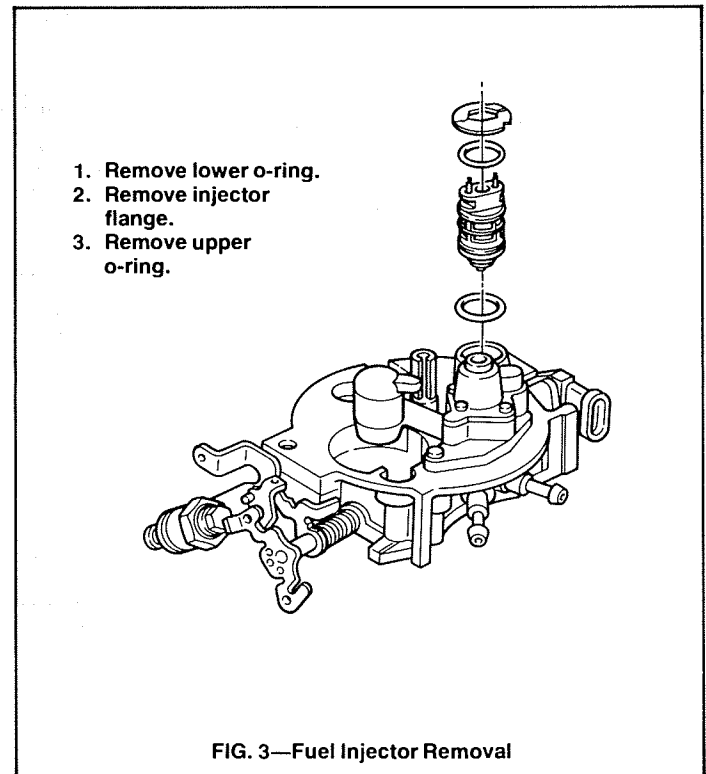
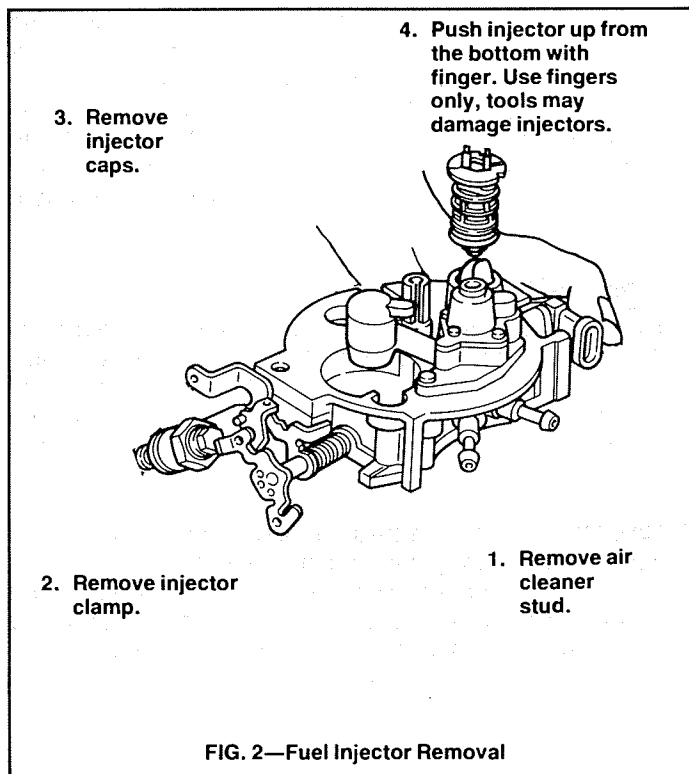
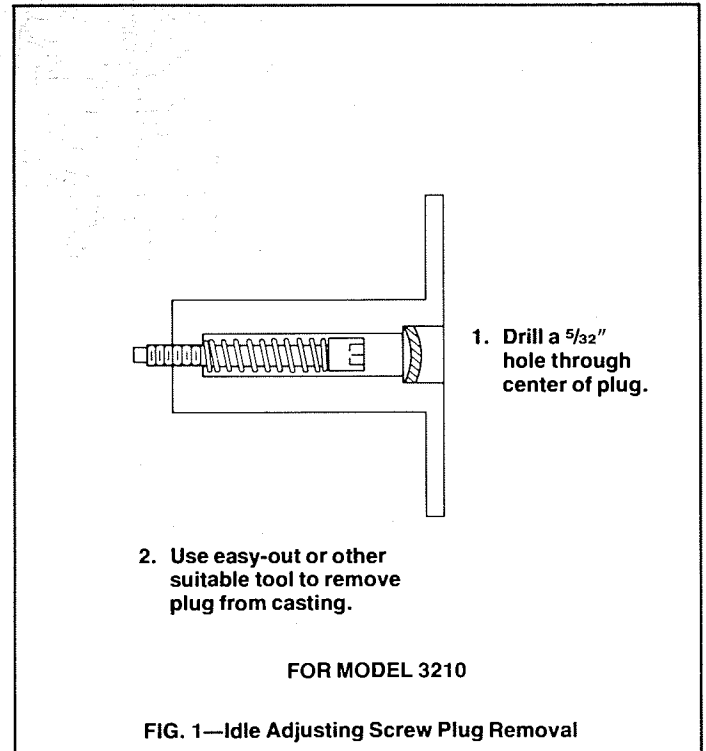

1. Lubricate o-rings with automatic transmission fluid.

2. Install the thinner o-ring over the lower end of the injector.

3. Install the thicker o-ring over the top of the injector.

4. Install injector flange around the top of the injector.

5. Push injector into cavity making sure the terminals line up with the injector caps.

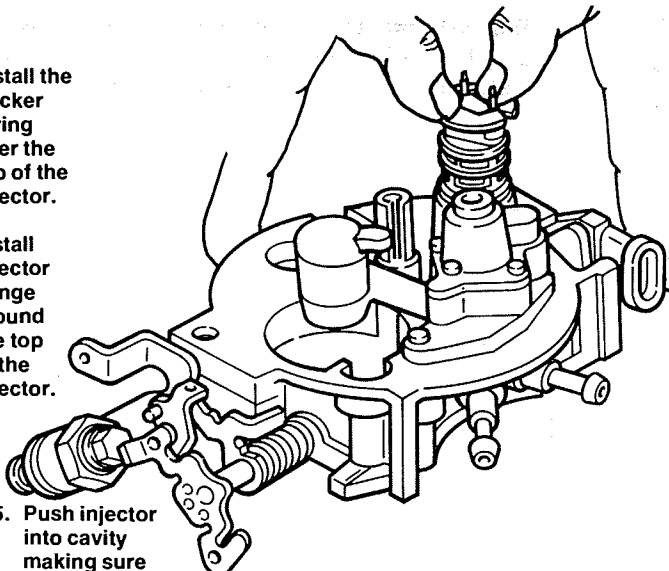

NOTE: LUBRICATE O RINGS BEFORE INSTALLING.

FIG. 4—Fuel Injector Installation

3. Install I.A.C. in throttle body. Tighten to 18 Nm (13 ft. lbs.).

1. Measure from motor housing to end of cone.

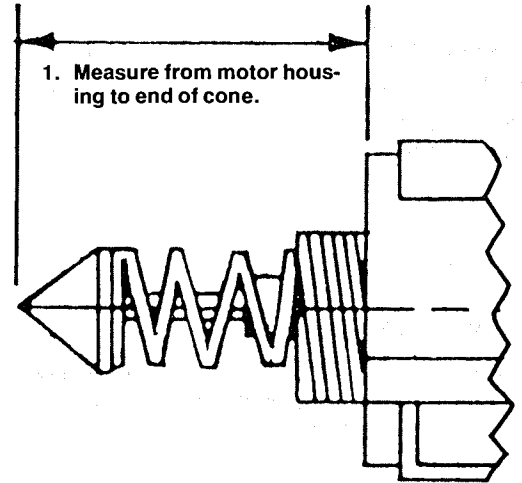

2. If measurement is greater than 32 mm (1 1/4") push on end of cone until it is in retracted position.

FOR MODEL 3210

FIG. 5—Idle Air Control Valve Installation

1. Make sure throttle valve is in normal closed idle position.



4. Connect digital voltmeter from TPS connector center terminal (B) to bottom terminal (A).

3. Make jumper wires with #16 #18 #20 wire. Use to connect TPS harness to TPS.

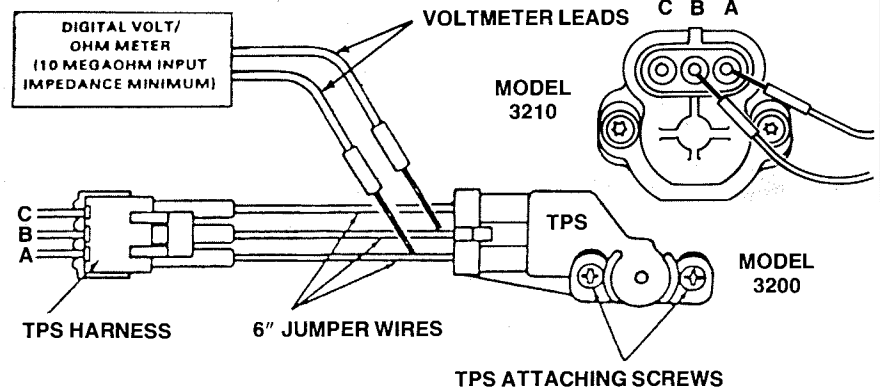

2. Install throttle position sensor making sure pick-up lever is located above tang on throttle actuator lever.

5. With ignition on engine not running, position TPS so voltmeter reads 0.63 volts for model 3200 and 0.50 volts for model 3210.

6. Tighten TPS mounting screws. Recheck voltmeter reading.

7. Turn ignition off. Disconnect voltmeter and reconnect all connectors.

FIG. 6—Throttle Position Sensor Installation and Adjustment

SERVICE PROCEDURE

FUEL SYSTEM PRESSURE TEST AND ADJUSTMENT

This test must be performed when checking and adjusting the fuel system.

Tools required:

Fuel Pressure Gauge Kits

Kent Moore

J29658

J34020

or

Snap On

MT321C

or

Borrough's

BT-8205B

CAUTION: It is necessary to relieve the fuel system pressure before servicing fuel system components. Fuel spray will occur if the following procedure is not followed.

To do this:

1. Model 3200 — Leave engine off for at least one hour after running to relieve fuel pressure.

Model 3210 — Remove fuse marked "fuel pump" from fuse block in passenger compartment. Start engine and allow to run until fuel supply remaining in

lines is consumed. When engine stalls, engage starter for three seconds to assure all pressure is relieved. Do not replace the fuse or turn the key to the run position until the fuel pressure gauge is installed.

2. Remove air cleaner and plug vacuum ports.
3. Install a fuel pressure gauge at the fuel inlet to the throttle body.
4. Start the car and observe the fuel pressure reading. It should read 12 P.S.I. for model 3210 and 13 P.S.I. for model 3200. Place a $\frac{5}{16}$ allen wrench into adjusting screw which is located on top of the fuel pressure regulator cover and turn screw to adjust pressure.
5. Depressurize fuel system, then remove fuel pressure gauge.
6. Reinstall fuel line.
7. Start car and look for any fuel leaks.
8. Remove the plug covering vacuum port and install the air cleaner.

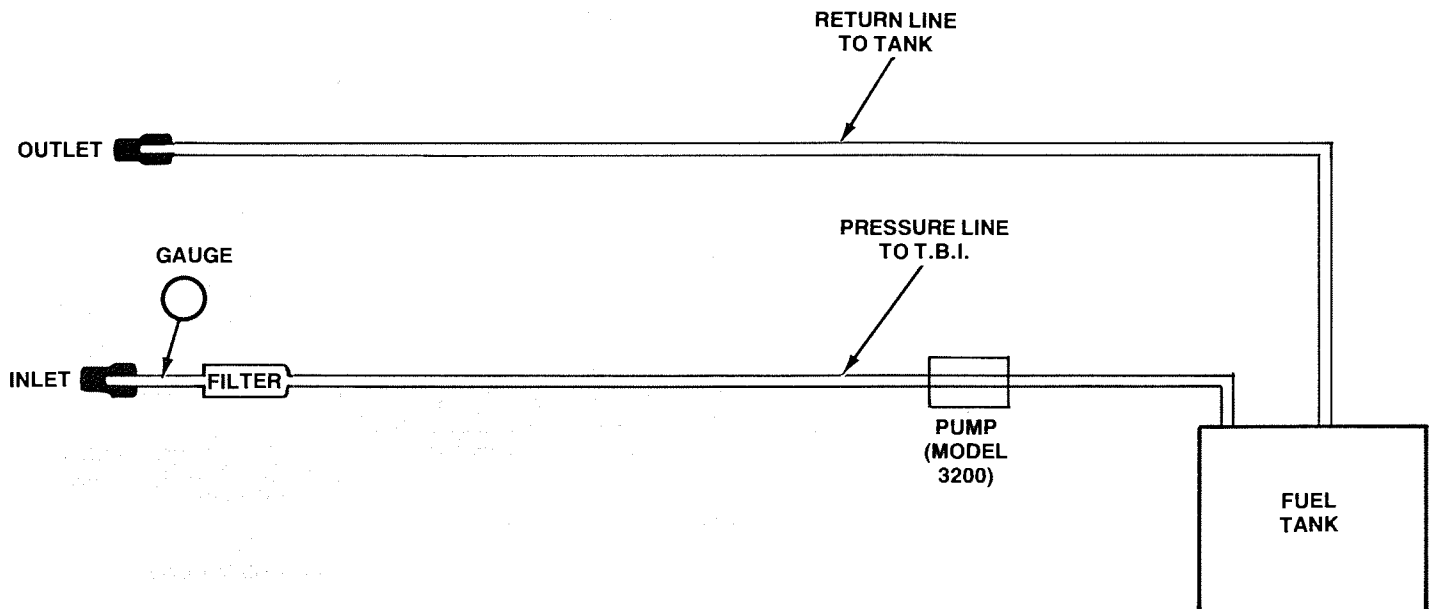

FIGURE 1