



2 BBL TBI HARDWARE KIT INSTALLATION MANUAL

P/N 199R10506



**P/N 550-200
670 CFM 2 BBL TBI
(V8 Engines up to 275 HP)**

NOTE: These instructions must be read and fully understood before beginning installation. If this manual is not fully understood, installation should not be attempted. Failure to follow these instructions, including the pictures may result in subsequent system failure.

TABLE OF CONTENTS:

1.0 INTRODUCTION	3
2.0 WARNINGS, NOTES, AND NOTICES	3
3.0 PARTS IDENTIFICATION	4
5.0 ADDITIONAL ITEMS REQUIRED FOR INSTALLATION	8
6.0 TOOLS REQUIRED FOR INSTALLATION	8
7.0 REMOVAL OF EXISTING FUEL SYSTEM	8
8.0 Avenger EFI TBI SYSTEM INSTALLATION	9
8.1 Throttle Body Installation	9
8.1.1 Installing Throttle Body on Square Flange Manifolds (see Fig. 1A)	9
8.1.2 Installing Throttle Body on Universal & Spread Bore Manifolds (see Fig. 1B & 1C)	9
8.1.3 Installing Throttle Body on Other Manifolds	10
8.1.4 Vacuum Line Connection to the Throttle Body	10
8.1.5 Throttle Lever Extension Bracket	11
8.1.6 Throttle Cable and Kickdown Brackets	11
8.1.7 Throttle Cable and Transmission Connectors	11
8.1.8 Air Temperature Sensor Installation	12
8.2 Map Sensor Installation	12
8.3 Fuel Pump Installation	12
8.4 Dual Tank Installation	13
8.5 Fuel Pump Filter	15
8.6 Throttle Body Fuel Filter	15
8.7 Return Line Installation	16
8.8 Return to fuel tank system	16
8.9 Fuel Line Connections to the Throttle Body	17
8.10 Oxygen Sensor Installation	17
8.10.1 Oxygen Sensor Mounting Procedure	17
9.0 THROTTLE BODY INJECTION SPECIFIC TUNING	18
9.1 ECU Mounting	18
10.0 WIRING	19
10.1 Important Wiring “Do’s and Don’ts”	19
11.0 WIRING HARNESS INSTALLATION	19
11.1 Main Power/Battery Connection	19
12.0 PRIMARY HARNESS INSTALLATION AND SENSORS CONNECTION	19
12.1 ECU Connectors	20
12.2 Harness Routing	20
12.3 Sensor Connections & Outputs	20
12.3.1 Throttle Position Sensor (TPS)	20
12.3.2 Manifold Air Pressure Sensor (MAP)	20
12.3.3 Coolant Temperature Sensor (CTS)	21
12.3.4 Manifold Air Temperature Sensor (MAT)	21
12.3.5 Wide Band Oxygen Sensor (WB02)	21
12.3.6 Fuel Pressure (Fuel)	21
12.3.7 Oil Pressure (Oil)	21
12.3.8 CANbus – Handheld (CAN)	22
12.3.9 Knock Sensor (Knock)	22
12.3.10 Ignition (IGN) –	22
13.0 PRIMARY OUTPUTS	23
13.1 Idle Air Control (IAC)	23
13.2 Fuel Injector Outputs (INJ)	23
14.0 LOOSE WIRES	23
15.0 IGNITION/ENGINE SPEED INPUT	24
16.0 WIRING	25
17.0 ADDITIONAL OUTPUTS	28
APPENDIX 1.0	29
Pinout	29

1.0 INTRODUCTION

Holley Performance Products has written this manual for the installation of the **Avenger EFI** 2 BBL TBI fuel injection system. This manual contains the information necessary for the hardware installation. Please read all the **WARNINGS, NOTES** and **TIPS**, as they contain valuable information that can save you time and money. It is our intent to provide the best possible products for our customer; products that perform properly and satisfy your expectations. Should you need information or parts assistance, please contact our technical service department at 1-270-781-9741, Monday through Friday, 8 a.m. to 5 p.m. CST. By using this number, you may obtain any information and/or parts assistance that you may require. Please have the part number of the product you purchased when you call.

NOTE: Use adapter P/N 17-47 for Holley 2300/Motorcraft 2bbl flange.

The 550-200 is a universal kit. Adapters are included for most square and spread bore manifolds. Engines that don't use square bore or spread bore intakes will likely need an adapter fabricated. Many times the adapters included can be modified for other applications. The customer is responsible for this and any throttle and transmission linkage modifications necessary.

NOTE: This manual is for the hardware installation of an Avenger Throttle Body Fuel Injection System and instructions specific to it. Instructions on wiring harness installation, software operation, sensor operation, and tuning is contained in the supplied additional manual 199R10505.

WARNING! The *Avenger EFI* TBI system consists of a number of sophisticated components. Failure of any one component does not constitute, nor does it justify, warranty of the complete system. Individual service items are available for replacement of components. If assistance is required or if you need further warranty clarification, you can call Holley Technical Service at the number shown above.

WARNING! To preserve warranty, these instructions must be read and followed thoroughly and completely before and during installation. It is important that you become familiar with the parts and the installation of the *Avenger EFI* TBI system before you begin. Failure to read and understand these instructions could result in damage to *Avenger EFI* TBI components that are not covered by the warranty and could result in serious personal injury and property damage.

WARNING! The oxygen sensor in this kit is designed to be used with **ONLY** unleaded fuels. Use of leaded fuels will destroy the oxygen sensor and will result in incorrect exhaust gas oxygen readings and improper fuel delivery. Failure to follow these directions does not constitute the right to a warranty claim.

WARNING! Failure to follow all of the above will result in an improper installation, which may lead to personal injury, including death, and/or property damage. Improper installation and/or use of this or any Holley product will void all warranties.

WARNING! Use of some RTV silicone sealers will destroy the oxygen sensor used with this product. Ensure the RTV silicone sealant you use is compatible with oxygen sensor vehicles. This information should be found on the oxygen sensor package.

2.0 WARNINGS, NOTES, AND NOTICES

WARNING! For the safety and protection of you and others, only a trained mechanic having adequate fuel system experience must perform the installation, adjustment, and repair. It is particularly important to remember one of the very basic principles of safety: fuel vapors are heavier than air and tend to collect in low places where an explosive fuel/air mixture may be ignited by any spark or flame resulting in property damage, personal injury, and/or death. Extreme caution must be exercised to prevent spillage and thus eliminate the formation of such fuel vapors.

WARNING! This type of work **MUST** be performed in a well-ventilated area. Do not smoke or have an open flame present near gasoline vapors or an explosion may result.

3.0 PARTS IDENTIFICATION

<u>ITEM</u>	<u>DESCRIPTION</u>	<u>QTY</u>	<u>SERVICE PART</u>
1	Avenger EFI ECU & Handheld Controller	1	554-116
2	Avenger EFI 2bbl Main Harness	1	N/A
3	Fuel Pump	1	12-927
4	Fuel Pump Clamp	1	N/A
5	Metal Fuel Filter	1	562-1
6	Oxygen Sensor	1	534-198
7	Fuel Filter Clamp	1	108-10
8	Fuel Pump Block-Off Plate & Gasket	1	12-813
9	Fuel Filter (WIX 33033)	1	N/A
10	MAP Sensor	1	538-24
11	Coolant Temperature Sensor	1	534-2
12	Air Cleaner Gasket	1	108-4
13	TBI Stud	3	N/A
14	Oxygen Sensor Weld Ring	1	534-49
15	40 AMP Relay	2	534-26
16	Throttle Bracket	1	N/A
17	Throttle and Cruise Control Stud	1	N/A
18	Throttle Lever Ball	1	N/A
19	Throttle Lever Bracket	1	20-2
20	Throttle Lever Shipping Spring	1	N/A
21	Throttle Lever Stud	1	20-38
22	Transmission Kickdown Stud	1	20-40
23	Hose Clamp	8	N/A
24	Grommet	1	N/A
25	Cable Ties	12	N/A
26	Tube Cap	1	N/A
27	Lockwasher	2	N/A
28	1/4-28 Nut	2	N/A
29	5/16-24 Nut	4	N/A
30	5/16" Vacuum Line	1	N/A
31	N/A		
32	Throttle Bracket	1	N/A
33	Throttle Bracket	1	N/A
34	Air Cleaner Spacer	1	17-14
35	Adapter	1	17-41
36	Adapter	1	17-45
37	Gasket	1	108-10
38	Distribution Ring	1	508-10
39	Gasket	1	508-5
40	Air Temperature Sensor	1	534-46
41	Gasket	1	N/A
42	Air Cleaner Stud	1	N/A
43	Throttle Stud	1	N/A
44	Bolt	3	N/A
45	Socket Screw	4	N/A
46	Socket Screw	4	N/A
47	Socket Screw	4	N/A
48	Bolt	3	N/A
49	Throttle Body	1	N/A
50	Plug	3	N/A
51	Locking Nut	4	N/A
<u>TBI Service Parts:</u>			
	Air Temperature Sensor	1	534-46
	Fuel Pressure Regulator Diaphragm	1	512-1
<u>Optional Parts:</u>			
	GM Distributor Wiring Adapter	1	558-304
	Ford Distributor Wiring Adapter	1	558-305



Item 1



Item 2



Item 3



Item 4



Item 5



Item 6



Item 7

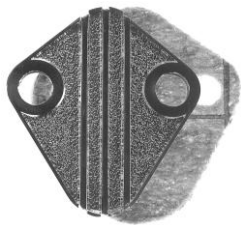

Item 8



Item 9



Item 10



Item 11

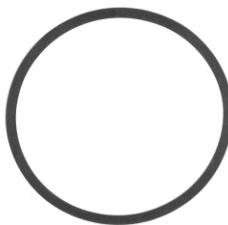

Item 12



Item 13



Item 14

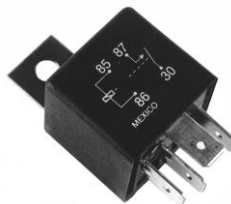

Item 15



Item 16



Item 17



Item 18



Item 19



Item 20



Item 21

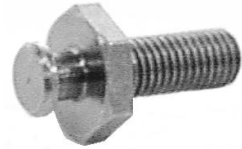

Item 22



Item 23



Item 24



Item 25



Item 26



Item 27



Item 28



Item 29



Item 30



Item 32



Item 33



Item 34

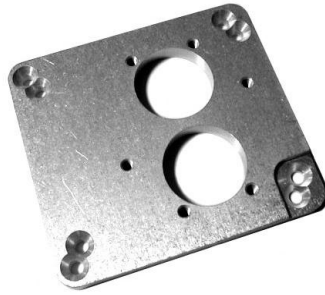

Item 35



Item 36



Item 37



Item 38



Item 39



Item 40



Item 41



Item 42



Item 43



Item 44



Item 45



Item 46



Item 47



Item 48

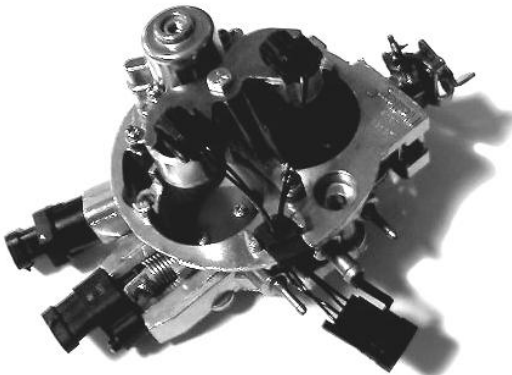

Item 49



Item 50



Item 51

5.0 ADDITIONAL ITEMS REQUIRED FOR INSTALLATION

- 3/8" fuel hose (must meet SAE J30)
- 5/16" steel fuel line (must meet SAE J526)
- Tee fitting for fuel gauge
- 5/16" fuel hose (must meet SAE J30)
- 0-30 psi fuel gauge or Holley Pressure Transducer

If an intake adapter other than the included square bore and spread bore adapters are needed, one must be fabricated by the customer. It is possible a new throttle and transmission cable bracket may be necessary.

6.0 TOOLS REQUIRED FOR INSTALLATION

- Standard wrench set
- Medium blade screwdriver
- Drill and assorted bit sizes
- Engine tachometer
- Factory Service Manual for your vehicle
- An assistant is necessary for some installation and adjustment procedures and should be present for safety reasons.
- Small blade screwdriver
- #2 Phillips screwdriver
- Hole saw (2")
- 10" adjustable wrench
- 5/32" Allen wrench
- Digital Volt-Ohm meter
- Terminal crimping tool
- Utility knife

7.0 REMOVAL OF EXISTING FUEL SYSTEM

1. Disconnect the battery and remove the air cleaner.
2. Before disconnecting any vacuum hoses, it is a good idea to sketch out the vacuum hose routing. Using masking tape and a permanent marker, mark all the vacuum hoses, vacuum sources, and ports before removing the old fuel delivery system.
3. Remove and discard the fuel line that connects the fuel delivery system from the fuel pump. This will not be needed in the installation.
4. Disconnect and plug the inlet fuel line that runs from the gas tank to the fuel pump. This will prevent fuel spillage and foreign matter or dirt from entering the fuel line.

DANGER! BEFORE DISCONNECTING OR REMOVING FUEL LINES, ENSURE THE ENGINE IS COLD. DO NOT SMOKE. EXTINGUISH ALL OPEN FLAMES. AN OPEN FLAME, SPARK, OR EXTREME HEAT NEAR GASOLINE CAN RESULT IN A FIRE OR EXPLOSION CAUSING PROPERTY DAMAGE, SERIOUS INJURY, AND/OR DEATH.

5. The fuel delivery system can now be removed. Holley recommends removing the mechanical fuel pump, if so equipped, and blocking-off the fuel pump mount using the provided fuel pump block off plate. The **Avenger EFI TBI** system kit includes a block-off plate that will fit small and big block Chevrolet and Chrysler engines. If the block-off plate does not fit your engine, a block-off plate may have to be purchased from a local performance parts supplier.
6. If required, replace the intake manifold at this time. Proceed to step seven if this is not required. **TO USE THE INCLUDED INTAKE ADAPTERS, A 4-BARREL STOCK OR AFTERMARKET INTAKE MANIFOLD IS REQUIRED.**
7. Place clean shop towels or rags into the manifold opening to prevent dirt or debris from entering the engine. Keep exposed ends of the vacuum and fuel lines free from dirt.

WARNING! Failure to cover the intake opening with a clean towel could result in dirt or debris entering the engine. Dirt or debris in the induction system can cause engine damage, which may necessitate a complete engine overhaul.

8. Remove all traces of the old gasket material from the TBI mounting flange. **DO NOT** gouge the intake manifold sealing surface during removal of old gasket material. Failure to remove all traces of the old gasket material will result in vacuum leaks that will be difficult to detect later. Sealing flanges must be clean and dry before installation.
9. Remove the shop towels from the intake and vacuum out the intake channel to ensure no dirt or debris is left in the intake system. Place a shop towel over the entire intake opening until you are ready to install the new **Avenger EFI TBI**.

8.0 Avenger EFI TBI SYSTEM INSTALLATION

8.1 Throttle Body Installation

8.1.1 Installing Throttle Body on Square Flange Manifolds (see Fig. 1A)

1. Clean the manifold flange and remove any residual gasket or sealing material. Make sure you do not drop any parts or debris in the engine. This may result in damage to the engine.
2. Place the Universal Manifold Adapter gasket on top of the manifold flange and position it so that the gasket covers all of the sealing surfaces.
3. Place the square flange adapter plate on top of the flange gasket so that the holes in the adapter plate are located towards the front of the vehicle.
4. Secure the adapter plate with the four socket head screws and torque the screws to 5 to 7 ft./lbs. in a criss-cross pattern.
5. Insert the coarse threaded end of the three 5/16" studs into the adapter plate and secure the studs to the adapter plate by screwing them into the adapter plate.
6. Place the TBI flange gasket over the three 5/16" studs.
7. Place the throttle body on top of the TBI flange gasket by placing the throttle body over the 5/16" studs.
8. Secure the throttle body in place with the three nylon locking nuts (item 54) and torque each of the nuts to 5 to 7 ft./lbs.

ADAPTERS

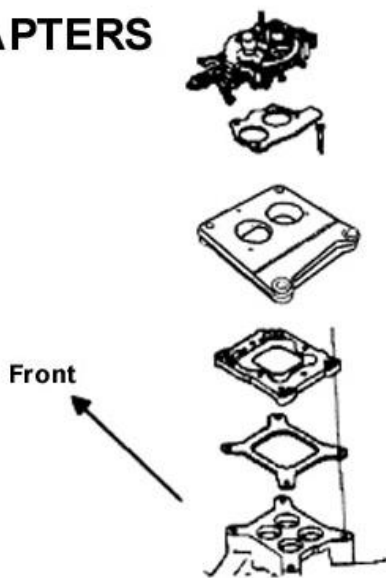

Figure 1A—Square Bore

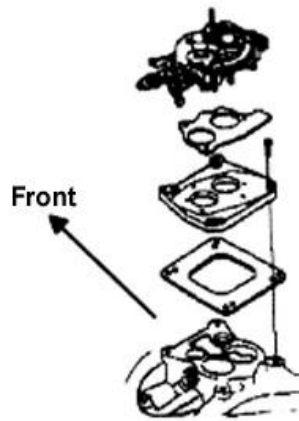

Figure 1B—SB Chevrolet

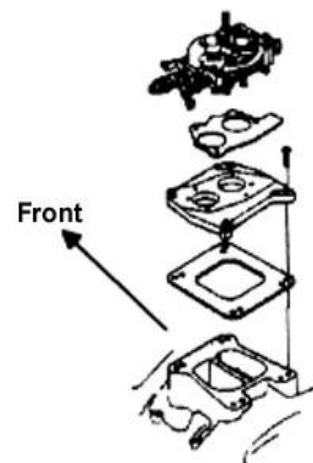

Figure 1C—All Other Spread Bore

8.1.2 Installing Throttle Body on Universal & Spread Bore Manifolds (see Fig. 1B & 1C)

NOTE: The Universal Manifold Adapter Plate has six threaded throttle body mounting holes. Only three of these will be used to mount the throttle body. The remaining three holes must be plugged by inserting a plug into each hole. Apply a small amount of Loctite® to each plug and secure them with a 5/32" hex wrench.

1. Clean the manifold flange and remove any residual gasket or sealing material. Make sure you do not drop any parts or debris in the engine. This may result in damage to the engine.
2. Place the Universal Manifold Adapter Gasket on top of manifold flange and position it so that the gasket covers all of the sealing surfaces.
3. Place the adapter plate on top of the flange gasket, placing the holes in the adapter plate towards the front of the vehicle.

NOTE: On Small Block Chevrolet applications with stock intake manifolds, the adapter plate should be installed so that the adapter plate's bores are located over the large secondary bores on the manifold. If you experience problems with the fit of the universal adapter plate, Holley recommends the installation of part #17-6, Spread Bore Adapter, underneath the Universal adapter plate. Use Holley adapter 17-47 for Holley 2300/Motorcraft 2 bbl flange.

NOTE: If you are using an aftermarket manifold with a Small Block Chevrolet application, position the adapter plate bores so that they are located towards the front of the intake manifold. On all other applications, except for those described, position the adapter plate bores so that they are located towards the front of the intake manifold.

NOTE: On stock Big Block Chevrolet applications, the throttle body must be mounted towards the front of the manifold, even though the bore holes will not line up correctly. This is necessary to prevent the front cylinders from running too lean. If you experience problems with the fit of the universal adapter plate, Holley recommends the installation of part #17-6, Spread Bore Adapter, underneath the Universal Adapter Plate.

4. Secure the adapter plate to the manifold with the four socket-head screws and torque them 5 to 7 ft./lbs. (60-84 in./lbs.) in a criss-cross pattern.
5. Insert the coarse threaded end of the three 5/16" studs into the adapter plate and secure the studs to the adapter plate by screwing the studs into the adapter plate.
6. Place the TBI flange gasket over the three 5/16" studs.
7. Place the throttle body on top of the TBI flange gasket by placing the throttle body over the 5/16" studs.
8. Secure the throttle body in place with the three locking nuts and torque each to 5-7 ft./lbs.

8.1.3 Installing Throttle Body on Other Manifolds

This system can be installed on any 4, 6, or 8 cylinder even fire engine. If an adapter plate is not available for the application, an existing spacer will have to be modified or a new one made. In many cases one of the existing adapter plates can be modified to fit other engines. If this does not work, a custom adapter will have to be machined.

8.1.4 Vacuum Line Connection to the Throttle Body

1. Inspect all of the vacuum lines that were disconnected during removal of the stock fuel system for any signs of wear or damage and replace those that are in need of repair.
2. Connect all of the vacuum lines that were labeled during the disassembly of the stock fuel system to the throttle body. **Figure 2** shows which ports are for manifold vacuum, ported vacuum, and PCV. The single fitting on the back of the throttle body is for manifold vacuum. There is a port on the other side of the throttle body as well. This is manifold vacuum. **HOWEVER, DO NOT CONNECT THE MAP SENSOR TO THIS PORT (Figure 3).**
3. Plug all of the vacuum ports on the throttle body that are not used with vacuum plugs. Failure to plug off unused vacuum ports will cause vacuum leaks, resulting in very poor performance.
4. Using the supplied vacuum line, connect the MAP sensor to a manifold vacuum source on the throttle body.

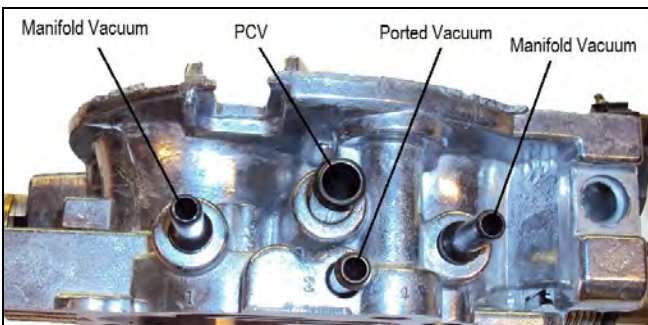

Figure 2

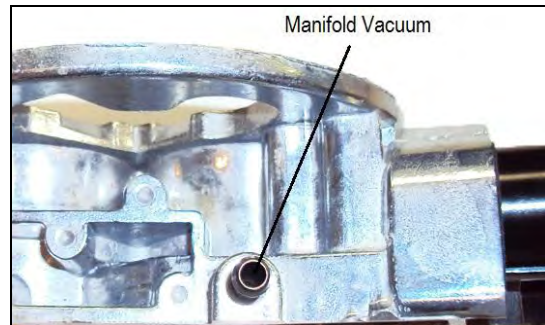

Figure 3

8.1.5 Throttle Lever Extension Bracket

NOTE: The installation of the throttle lever extension bracket onto the throttle body is OPTIONAL. This bracket is used to provide a gentler rate at which the throttle opens and to reduce the force required to depress the accelerator pedal. Ensure that there is sufficient clearance between the bracket and the air cleaner assembly to prevent any binding.

1. Locate that throttle lever extension bracket, two hex head bolts, three lockwashers, three hex nuts, and the transmission kick-down stud.
2. Secure the bottom hole of the bracket to the bottom hole of the throttle lever on the throttle body with one of the hex head bolts and secure it to the throttle lever with a hex nut and lockwasher. If you are installing a transmission kick-down cable or lever, secure the throttle lever extension bracket throttle lever with the transmission kick-down stud instead of a hex bolt.
3. Secure the center hole on the bracket to the top hole of the throttle lever on the throttle body with one of the hex head bolts, hex nuts, and lockwashers.
4. Install the throttle arm stud or ball stud in the top hole of the throttle lever extension bracket and secure the stud with one of the hex and lockwashers.

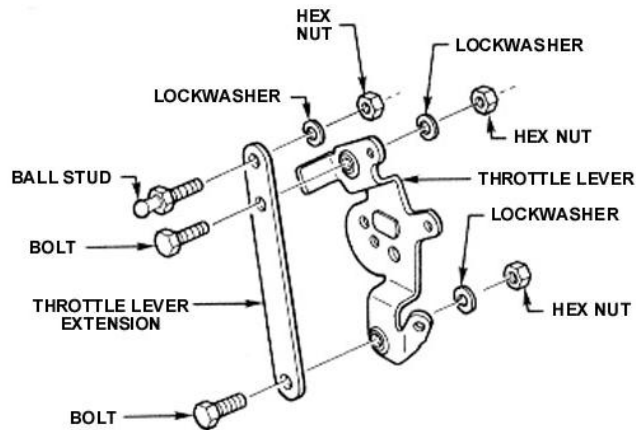

Figure 4

8.1.6 Throttle Cable and Kickdown Brackets

NOTE: General Motors automatic overdrive transmissions require the use of a special bracket and/or hardware to ensure proper operation.

1. For vehicles equipped with an aftermarket 4 barrel intake manifold and a GM TH700R4 transmission, use Holley PN 20-97.

NOTE: For Ford automatic overdrive transmissions, a linkage kit is available from Lokar at 1-865-966-2269.

NOTE: For Chrysler applications, the use of a kick-down linkage kit is required to actuate the Chrysler transmission linkage, Holley PN 20-7. Chrysler van applications may require the use of a throttle lever extension, Holley PN 20-14.

NOTE: Some General Motors vehicles require the installation of a stud in the driver's side rear corner of the adapter plate for use when mounting the appropriate throttle bracket.

1. Select the appropriate throttle bracket for you application (if available). The longer of the two brackets is usually used on stock manifold applications, while the shorter bracket is usually used with aftermarket manifolds.
2. Install the bracket over the stud installed in the rear driver's side corner of the adapter plate and secure the bracket with a 5/16"-24 hex nut.

NOTE: For General Motors spread bore applications, also install the transmission bracket. This bracket will move the cable to compensate for the throttle body being mounted over the secondary bores.

8.1.7 Throttle Cable and Transmission Connectors

NOTE: On some Ford applications, it may be necessary to lengthen the automatic transmission kick-down rod for proper

transmission operation. A kit used to lengthen this rod is available from Holley, PN 20-41.

DANGER! PROPERLY ADJUST BOTH THE THROTTLE CABLE AND TRANSMISSION LEVER/CABLE. FAILURE TO DO SO MAY RESULT IN UNCONTROLLED ENGINE AND VEHICLE SPEED, RESULTING IN PROPERTY DAMAGE, PERSONAL INJURY, AND/OR DEATH.

1. Attach the throttle cable to the stud installed on the throttle linkage on the throttle body.
2. While another person fully depresses the accelerator pedal, adjust the throttle cable to ensure that the travel of the accelerator pedal allows for both wide open throttle and idle.
3. Once the throttle cable has been adjusted, operate the linkage several times back and forth to ensure that it operates smoothly, with no binding or sticking.
4. Attach the transmission kick-down lever, or overdrive cable, to the appropriate bracket, and adjust either the lever or the cable to ensure that the transmission operates properly.

WARNING! Over tightening the TBI manifold flange hold-down-nuts may result in a warped or cracked throttle body. The TBI hold down nuts should be tightened down progressively in a criss-cross pattern to 5-7 ft lbs., to prevent leaks and avoid causing damage to the throttle body. A TBI that has been damaged due to negligence of the owner will void the warranty.

8.1.8 Air Temperature Sensor Installation

The air temperature sensor should be installed somewhere in the inlet tract. The air temp sensor has a two-pin Packard connector with blue and black wires. The 199R10505 instruction manual includes the wiring harness installation.

8.2 Map Sensor Installation

The MAP sensor will have to be mounted to the engine or the firewall. The MAP sensor should be mounted so that the vacuum port is facing completely down or at an angle. If it is not, fuel or condensation can enter the sensor and damage it. Make sure a vacuum line is connected from the MAP sensor to a manifold vacuum source on the throttle body.

8.3 Fuel Pump Installation

1. Do not mount the fuel pump higher than the lowest point of the fuel tank.
2. Mount the fuel pump as close as possible to the fuel tank.
3. Make sure fuel tank is properly vented.

DANGER! NEVER GET UNDER A VEHICLE SUPPORTED ONLY BY A JACK. SERIOUS INJURY OR DEATH CAN RESULT FROM VEHICLES FALLING OFF OF JACKS. BEFORE WORKING UNDERNEATH A VEHICLE, SUPPORT IT SOLIDLY WITH JACK STANDS.

4. Mount the electric fuel pump as close to the fuel tank outlet as possible with the bracket provided. Mounting the fuel pump in this manner will insure that the pump will prime easily and purge fuel vapors in the TBI quickly to ensure faster starts.

DANGER! TAKE PRECAUTIONS TO ENSURE THAT ALL FUEL LINE ROUTINGS ARE AWAY FROM HEAT SOURCES, SUCH AS THE ENGINE OR EXHAUST PIPES. A FIRE OR EXPLOSION HAZARD COULD CAUSE SERIOUS INJURY OR DEATH.

DANGER! ENSURE THAT THE FUEL PUMP MOUNTING LOCATION WILL NOT INTERFERE WITH ANY UNDER THE VEHICLE COMPONENTS, ESPECIALLY AT THE EXTREME LIMITS OF THE SUSPENSION TRAVEL. A FIRE OR EXPLOSION HAZARD COULD CAUSE SERIOUS INJURY OR DEATH.

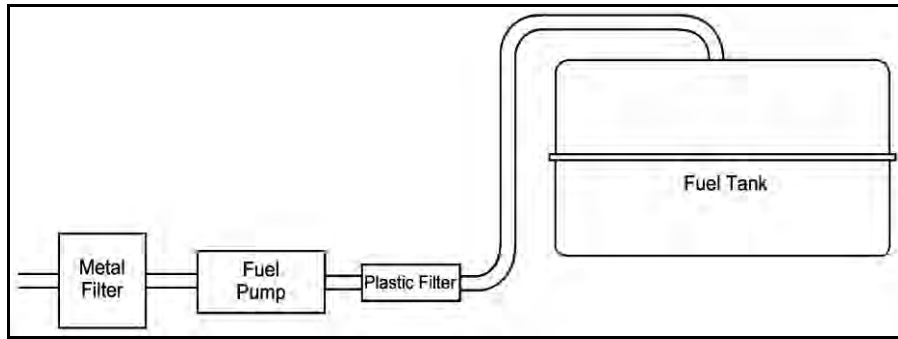

Figure 5

5. Connect the pump to the tank using 3/8" I.D. fuel hose. Connect the outlet of the pump to the steel line, which runs to the front of the vehicle with 3/8" I.D. fuel hose, depending on the diameter of the steel fuel line. All fuel hoses used must meet SAE J30 performance standards.

DANGER! FAILURE TO USE A FUEL HOSE THAT MEETS SAE J30 STANDARDS COULD RESULT IN FUEL LEAKS. A FUEL LEAK MAY RESULT IN A FIRE OR EXPLOSION HAZARD, WHICH COULD CAUSE SERIOUS INJURY OR DEATH.

6. If using the existing fuel lines, inspect and replace any hose, clamps, or fuel line showing **ANY** sign of aging. If you are not using existing fuel lines, you will need a fuel line routed to the engine compartment and **Avenger EFI** throttle body. Use a 3/8" steel fuel line available at any auto parts store. All steel fuel line must meet SAE J526 standards.

DANGER! FAILURE TO USE STEEL A FUEL LINE THAT MEETS SAE J526 STANDARDS COULD RESULT IN FUEL LEAKS. A FUEL LEAK MAY RESULT IN A FIRE OR EXPLOSION HAZARD, WHICH COULD CAUSE SERIOUS INJURY OR DEATH.

DANGER! TAKE PRECAUTIONS TO ENSURE THAT ALL FUEL LINE ROUTINGS ARE AWAY FROM HEAT SOURCES, SUCH AS THE ENGINE OR EXHAUST PIPES. A FIRE OR EXPLOSION HAZARD COULD CAUSE SERIOUS INJURY OR DEATH.

DANGER! RIGID FUEL LINE TUBING SHOULD BE USED FOR UNDER VEHICLE RUNS, SUCH AS ALONG VEHICLE FRAME RAILS OR UNDER FLOOR PANS. FAILURE TO DO SO IS A POTENTIAL FIRE OR EXPLOSION HAZARD, WHICH COULD CAUSE SERIOUS INJURY OR DEATH.

7. Anchor all fuel lines securely to solid chassis members at 1 ½ foot intervals using rubber coated steel clamps. Use of only approved steel fuel line tubing will afford maximum fuel line protection against road hazards and premature wearing due to flexing, temperature extremes, road salt, weather, etc.

NOTE: Inlet fuel pressure should be preset to 21 PSI from the factory.

8.4 Dual Tank Installation

The following are special instructions for vehicles equipped with dual fuel tanks. Holley **Avenger EFI** fuel injection systems require a fuel return line and in dual tank applications, the fuel must be returned to the tank from which it was drawn. The items listed below are recommended to properly install your **Avenger EFI** TBI system on a dual tank vehicle. A separate fuel pump and filter for each tank will be necessary.

Holley offers these items in a kit, part number **534-37**.

Item	Part Number
Selection valve	N/A
Valve Connector	N/A
Toggle switch	N/A
Relay	534-26
Fuel pump	12-927
10 amp in line fuse	N/A
Fuel filter	562-3

This is a recommended list and except for the fuel pump, equivalent parts may be substituted. In addition, fuel hose, clamps, 18 gauge wire, and assorted terminals will be needed. The selection valve recommended switches tanks by reversing the polarity of the "D" and "E" terminals. Many trucks equipped with dual tanks already have this type of selection valve along with the associated hardware.

1. Mount the selection valve in a protected location close to the existing fuel lines and near the fuel tanks. Position the valve so the side with the four hose nipples points toward the fuel tanks. Mount the fuel pumps along the fuel supply lines and next to each fuel tank. Fuel filters (Holley Part Number 562-3) MUST be located between each tank and pump. Make sure pump inlets point toward the tanks. (See Figure 6).

WARNING! The supply and return hoses from the same tank must be connected next to each other on the selection valve.

2. All hoses should be secured with worm gear type clamps. Avoid sharp bends in the fuel lines.
3. Mount the double-position, double-throw toggle switch, along with the relay under the dash if the vehicle is not already equipped with this type switch. Connect the electrical wiring, as shown in Figure 7 on the next page.

NOTE: Mount the double-position, double-throw toggle switch along with the relay under the dash if the vehicle is not already equipped with this type switch. Connect the electrical wiring, as shown in Figure 7 on the next page.

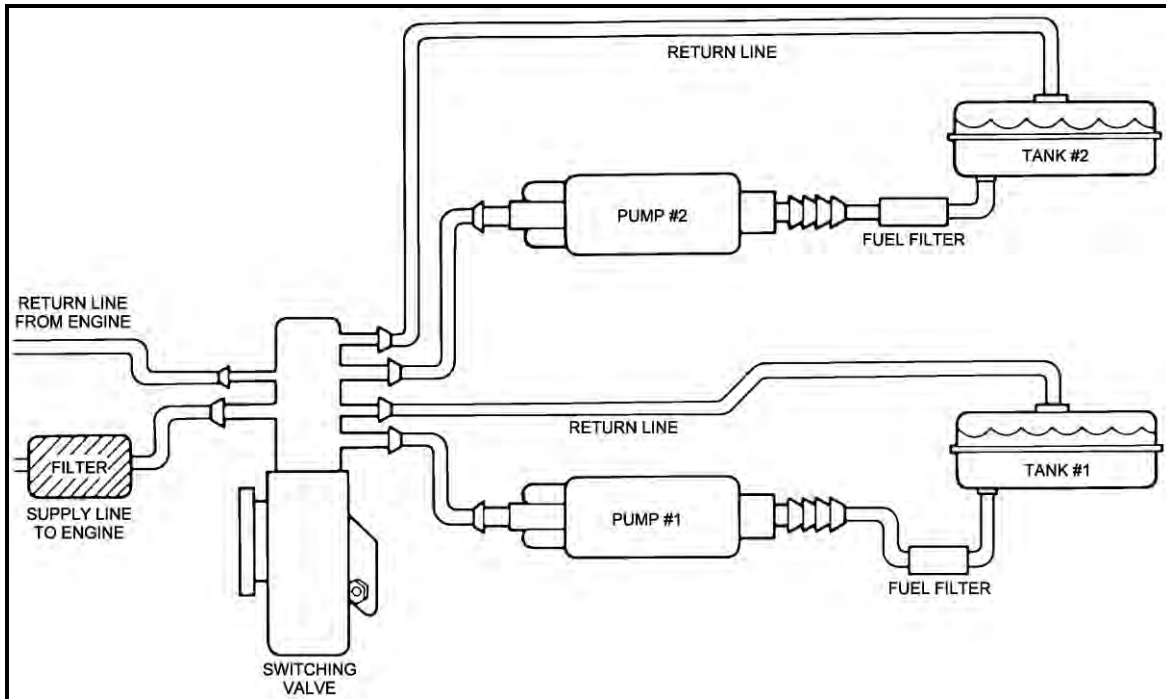

Figure 6

The terminals on the plug-in connector are labeled A - F and should be wired to the following items:

- A Fuel sending unit, tank #1
- B Fuel gauge at dash
- C Fuel sending unit, tank #2
- D Fuel pump #2 (+12v) and switch
- E Fuel pump #1 (+12v) and switch
- F Not used

4. Plug the connector into the selection valve. Double check all fuel and electrical connections to be sure they are installed properly. Electrical connections should be insulated and sealed to prevent arcing and corrosion. Check the operation of the selection valve when the **Avenger EFI** TBI system installation is complete.

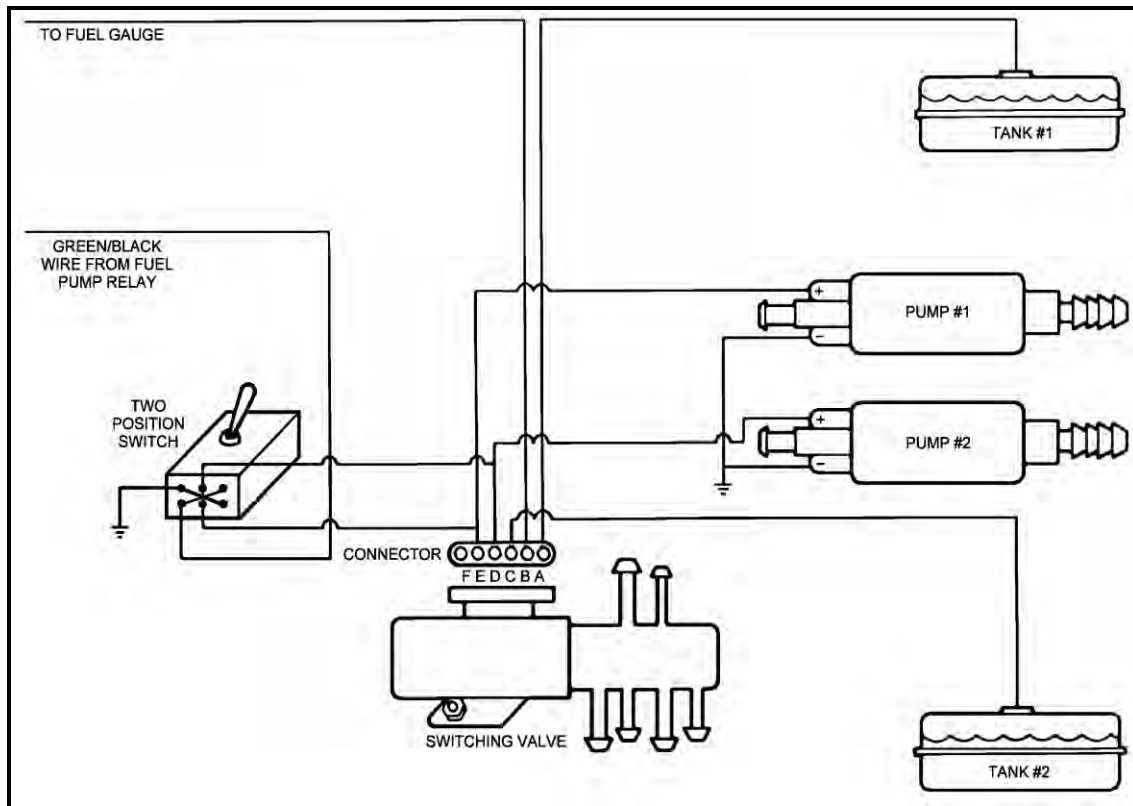

Figure 7

8.5 Fuel Pump Filter

A filter **MUST** be installed between the fuel tank and the fuel pump inlet (included in kit – marked WIX 33033). The purpose of this filter is to protect the fuel pump from particles of dirt or other foreign material. The filter should be installed with the arrow on the filter pointing in the direction of the fuel flow. Secure the ends of the fuel lines with hose clamps.

8.6 Throttle Body Fuel Filter

The 10 micron metal fuel filter that is included with the *Avenger EFI* TBI system should be installed between the electric pump outlet and the inlet fitting of the TBI. Position the filter, so the fuel hoses can be routed without kinks or sharp bends. The filter should be installed with the arrow on the filter pointing in the direction of the fuel flow. Secure the ends of the fuel lines with hose clamps. Conveniently mount the fuel filter and clamp assembly using the hole provided in the clamp.

WARNING! Ensure both filters are installed in the proper direction. A flow direction arrow is stamped on the side of the filter to indicate the direction of fuel flow. Failure to do so will result in a system malfunction.

DANGER! TAKE PRECAUTIONS TO ENSURE ALL FUEL LINE ROUTINGS ARE AWAY FROM HEAT SOURCES, SUCH AS THE ENGINE OR EXHAUST SYSTEM. A FIRE OR EXPLOSION HAZARD COULD CAUSE PROPERTY DAMAGE, SERIOUS INJURY, AND/OR DEATH.

8.7 Return Line Installation

The Holley *Avenger EFI* TBI system requires a return fuel line to the fuel tank. Some late model vehicles that were originally equipped with a throttle body injection system may already have a return line to the fuel tank that can be utilized. If a return fuel line must be installed, a minimum size of 5/16" I.D. is recommended.

DANGER! DO NOT USE THE VAPOR CANISTER LINES AS A FUEL RETURN LINE. POSSIBLE FUEL LEAKS MAY CREATE A FIRE OR EXPLOSION HAZARD, CAUSING SERIOUS INJURY OR DEATH.

WARNING! Use only approved steel fuel line. The return fuel line should enter the fuel tank at the "fuel level sending unit flange" or at the "filler neck". The filler neck or sending unit must be removed from the tank to perform this operation.

DANGER! PROPER INSTALLATION OF THE FUEL RETURN LINE MAY NECESSITATE COMPLETE REMOVAL OF THE FUEL TANK. THIS WORK SHOULD BE DONE BY A FUEL TANK SPECIALIST, WHO REGULARLY DOES THIS WORK AND IS FAMILIAR WITH SAFETY REGULATIONS AND PRECAUTIONS NECESSARY TO DO THIS WORK. IF A PERSON ATTEMPTS THIS WORK, WHO IS NOT FAMILIAR WITH THE SAFETY REGULATIONS AND PRECAUTIONS, AN EXPLOSION HAZARD MAY RESULT CAUSING SERIOUS INJURY OR DEATH.

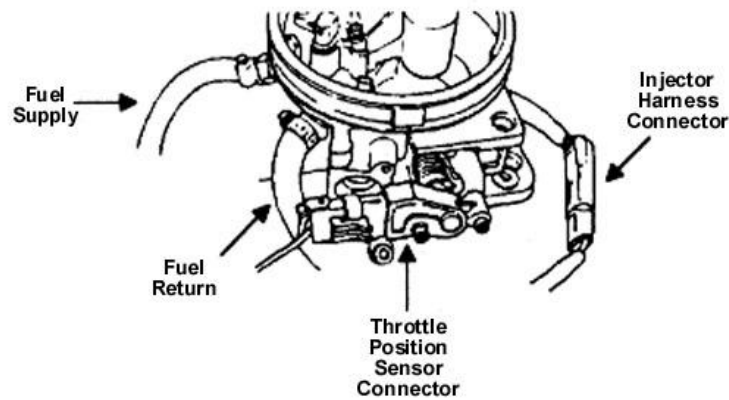

Figure 8

8.8 Return to Fuel Tank System

1. Install a 5/16" return line hose from the 5/16" return fitting in the throttle body to a fitting in the fuel tank. Use the supplied hose clamps to ensure that the fuel line fittings are tight at both ends of the hose.

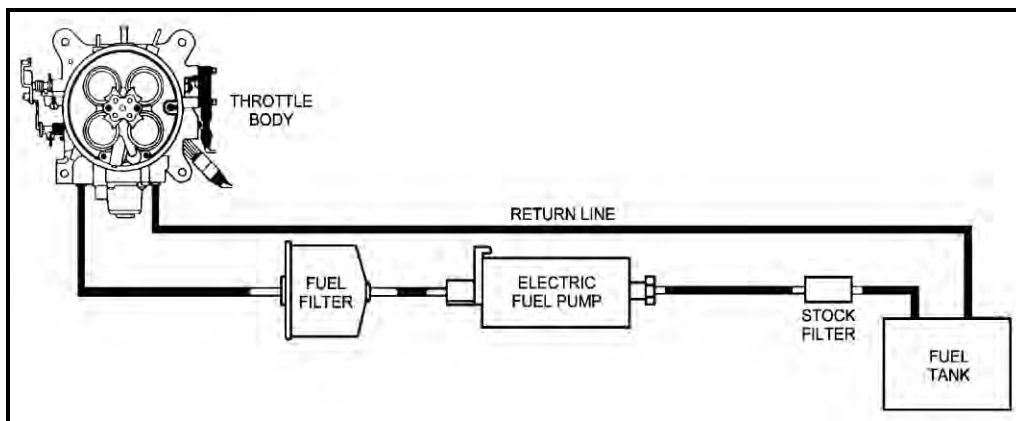

Figure 9

The system tuning and checkout process advises that a fuel pressure gauge be installed in the return line system. This is a good time to consider how this pressure gauge can be installed. Attach a section of 5/16" hose to the outlet of the throttle body and secure with a hose clamp. Run the other end to either the fuel tank or the inlet of the pump at the tee fitting as previously discussed in earlier text. Secure with a hose clamp.

NOTE: The return line pressure should be as close to -0" zero as possible. The fuel pressure should be no higher than 3 psi.

8.9 Fuel Line Connections to the Throttle Body

WARNING! The fuel pressure in the fuel return line **MUST** be less than 3 PSI for the system to operate properly. Fuel return line pressure of 3 PSI or more will result from the return line being too small, a restriction in the line, or too many bends. Return fuel pressure in excess of 3 PSI may result in an excessive fuel condition (flooding) which may cause stalling or hard starting.

1. Locate the fuel inlet fitting on the throttle body. It is located on the driver's side of the vehicle with the fuel fittings facing the rear of the vehicle.
2. Attach the fuel supply line to the fuel inlet fitting on the throttle body with 3/8" ID J30 fuel hose and secure the fuel supply line to the fitting with a hose clamp.
3. Locate the fuel outlet fitting on the throttle body. It is located on the passenger side of the vehicle with the fuel fitting facing the rear of the vehicle.
4. Attach the fuel return line to the fuel return outlet fitting on the throttle body with 5/16" ID J30 fuel hose and secure the fuel return line to the fitting with a hose clamp.

8.10 Oxygen Sensor Installation

It is recommended to mount the oxygen sensor as close as possible, where one bank of cylinders merge together. If an OEM mounting location is available, use it. With stock cast iron manifolds, the sensor can be mounted in the exhaust pipe, right after the cast iron manifold in the exhaust pipe or possibly in the end of the manifold itself. If the vehicle has "shorty" headers, the sensor can be mounted in the collector of the headers.

If the vehicle has long tube headers, the sensor can be mounted in the collector, but the temperature will likely be too low at idle for proper operation. A fix for this, if proper closed loop operation does not occur, is to run open loop at lower engine speeds, until enough heat is available for proper operation. This is programmable in the ECU. Other factors, such as camshaft specifications, will affect how well closed loop operation occurs at low engine speeds and loads.

8.10.1 Oxygen Sensor Mounting Procedure

NOTE: Never run the engine with the oxygen sensor installed if it is not plugged in and powered by the ECU, or it will be damaged. If you need to plug the hole temporarily, use an O2 sensor plug or a spark plug with an 18mm thread.

NOTE: Someone with experience in welding exhaust systems should install the oxygen sensor boss. Any competent exhaust shop is able to perform this task at a minimum cost.

WARNING! Use only unleaded fuel when operating an oxygen sensor. Use of leaded fuels will destroy the oxygen sensor and will result in incorrect exhaust gas oxygen-content readings.

WARNING! Use of some RTV silicone sealers will destroy the oxygen sensor used with this product. Ensure the RTV silicone sealant you use is compatible with oxygen sensor vehicles. This information should be found on the oxygen sensor package.

Avenger EFI systems come with a Bosch wideband oxygen sensor. Make sure your sensor looks like **Figure 10**.



Figure 10

1. Locate a position for the oxygen sensor as close to the engine as possible. If your vehicle has catalytic converters, the oxygen sensor **MUST** be located between the engine and the catalytic converters.

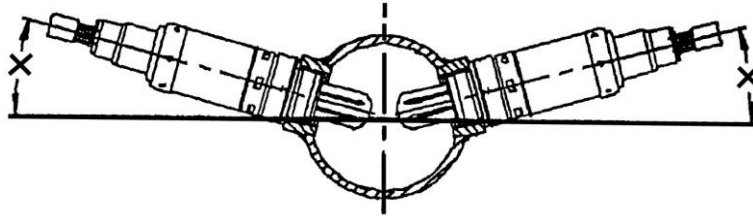

Figure 11

NOTE: The oxygen sensor should be mounted in such a way that the condensation in the exhaust tubing will not enter the sensor. Mount the O² sensor in the upper half of the exhaust tubing, with the angle “x”, shown above, being greater than 10°. The picture above indicates that the sensor can be mounted on either side of the exhaust tubing.

2. Drill a 7/8” hole in the location picked for the sensor. Weld the threaded boss into the 7/8” hole. Weld all the way around the boss to insure a leak proof connection. Install the oxygen sensor into the threaded boss and tighten securely. It is a good idea to add anti-seize to the threads to aid in removal.
3. On vehicles equipped with an AIR pump, the oxygen sensor must be mounted before the AIR injection into the exhaust, or the AIR pump must be disconnected. Holley recommends that if the AIR is injected into both exhaust manifolds; mount the oxygen sensor into the pipe immediately after the exhaust manifold. Disconnect the AIR pump tube from the exhaust manifold and plug both ends. Check with local ordinances for the legality of this procedure in your area.

WARNING! Failure to disconnect the AIR pump or locating the oxygen sensor downstream from AIR injection will result in an extremely rich mixture, which could cause driveability problems and severe engine damage.

WARNING! It is important that the distribution ring is properly installed and fastened to the throttle body. Failure to do so will cause an inadequate seal between the throttle body and air cleaner and may be a fire hazard in the event of a backfire. Fire hazard can result in property damage, serious injury, and/or death.

9.0 THROTTLE BODY INJECTION SPECIFIC TUNING

The throttle body injection (TBI) systems have several items to note. The factory should have preset the fuel pressure at 21 psi. This should be checked, if possible, before the tuning is performed. The injectors can operate down to 10 psi. The pressure can safely be raised above 21 psi.

9.1 ECU Mounting

The ECU can be mounted inside the passenger compartment (preferable location), or in the engine compartment. If mounted in the engine compartment, follow these guidelines:

- The ECU should be located such that it isn't being directly hit by water or road debris.
- It should also be located such that it isn't extremely close to exhaust manifolds or headers.
- It should be mounted such that it is as far away from spark plug wires, CD ignition boxes, or other “electrically noisy” devices as is reasonable possible.

The ECU comes with mounting hardware and vibration absorbers. Mount the vibration absorbers between the ECU feet and the mounting location. Do not over-tighten the mounting hardware if the ECU is not mounted on a flat surface.

10.0 WIRING

The following overviews how to properly install the wiring harnesses for this system.

10.1 Important Wiring “Do’s and Don’ts”

An EFI system depends heavily on being supplied a clean and constant voltage source. The grounds of an electrical system are just as important as the power side.

Avenger ECU’s contain multiple processing devices that require clean power and ground sources. The wiring harnesses for them must be installed in such a manner that they are separated from “dirty” power and ground sources.

DO’S

- Install the main power and ground directly to the battery.
- Keep sensor wiring away from high voltage or “noisy/dirty” components and wiring, especially secondary ignition wiring (plug wires), ignition boxes and associated wiring.
- Properly solder and heat shrink any wire connections.
- It is critical that the engine has a proper ground connection to the battery and chassis.

DON’TS

- NEVER run high voltage or “noisy/dirty” wires in parallel (bundle/loom together) with any EFI sensor wiring. If wires need to cross, try to do so at an angle.
- Do not use the electric fan outputs to directly power a fan. They must only trigger a relay.
- Do not use improper crimping tools.
- Don’t use things like “t-taps”, etc. Use solder and heat shrink.
- It is never recommended to splice/share signal wires (such as TPS, etc) between different electronic control units.

11.0 WIRING HARNESS INSTALLATION

11.1 Main Power/Battery Connection

The AVENGER ECU has a main battery power and ground connector on the right side of the ECU. The bottom position, Terminal “A” is the ground. The upper position, Terminal “B” is the positive terminal. Always use the fused power cable with the proper connectors supplied by Holley only.



Figure 12

12.0 PRIMARY HARNESS INSTALLATION AND SENSORS CONNECTION

These sections review the Main Harness installation and all of the sensor connections that must be completed. The Main Harness is the primary harness that supports all the primary engine sensors, fuel and ignition. There are two main connectors for this harness that plug into the ECU.

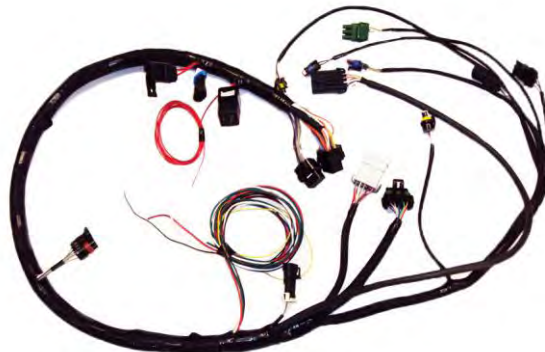

Figure 13

12.1 ECU Connectors

AVENGER ECU – The AVENGER ECU has **two** main connectors:

- **P1A** - The first connector next to the USB connector is the “P1A” connector (34 pin). This connector is primarily an “Input” connector. It contains all the sensor inputs and wide band oxygen sensor control.
- **P1B** - The second connector is the “P1B” connector (26 pin). This connector is the “output” connector. It has 8 injector outputs and outputs for other devices.

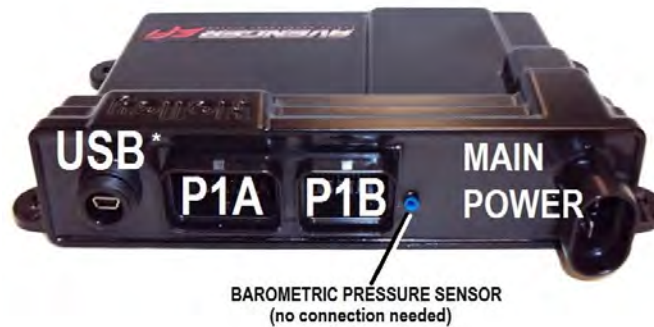

Figure 14

*USB is not used on Avenger EFI

12.2 Harness Routing

If the ECU is mounted in the interior, it will have to be routed through the firewall into the engine compartment. Use a 2” hole saw to create a hole in a desired location if no other point of access is available. A grommet is supplied for a 2” hole to seal this area.

If the ECU is mounted in the engine compartment, the hand-held tuning module cable will have to be routed to the “CAN” connector on the main harness (located near the ECU connector main connector). This will require routing 1” x ½” connector somewhere through the firewall.

Connect the P1A and P1B connectors of the main harness into the ECU.

About 12” from the ECU main connectors is a 40A Relay. This powers the injectors and fuel pump.

12.3 Sensor Connections & Outputs

The following indicates the primary sensors that are required to be connected. Each connector on the main harness is labeled with the sensor name. The name on this label for each sensor is in parenthesis below.

12.3.1 Throttle Position Sensor (TPS)

Connect to the TPS which is located on the throttle body.

12.3.2 Manifold Air Pressure Sensor (MAP)

A 1 Bar MAP sensor is provided with all Holley EFI systems. Connect to the MAP sensor. Make sure that a vacuum line was connected to the MAP sensor in previous steps.

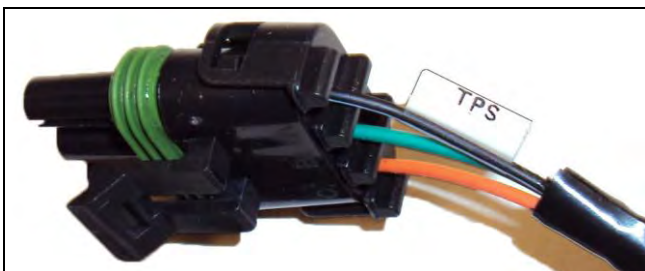

Figure 15 TPS

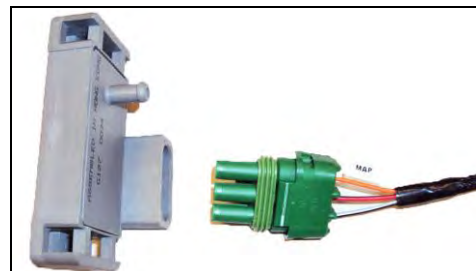

Figure 16 MAP

12.3.3 Coolant Temperature Sensor (CTS)

Connect to the Coolant Temperature sensor which should have been installed in an engine coolant passage.

12.3.4 Manifold Air Temperature Sensor (MAT)

Connect to the Air Temperature Sensor. This is located in the throttle body unit.



Figure 17 CTS



Figure 18 MAT

12.3.5 Wide Band Oxygen Sensor (WB02)

Connect to the oxygen sensor connector to the oxygen sensor previously installed. If you need an extension cable, one is available from Holley (P/N 534-199). The Avenger systems are intended to be used with a Bosch wide band oxygen sensor supplied by Holley. Make sure yours is the same as the picture below:



Figure 19 WB02

12.3.6 Fuel Pressure (Fuel)

A fuel pressure transducer connector is pre-installed in the main harness. The system is plug-and-play configured for a Holley 100 PSI pressure transducer (can be purchased under PN 554-102). If these are not connected to a pressure transducer, the Fuel and Oil Pressure will read "LEr" on the hand-held display. This will not cause any issues. Connect to the transducer (if installed).

12.3.7 Oil Pressure (Oil)

An oil pressure transducer connector is pre-installed in the main harness. The system is plug-and-play configured for a Holley 100 PSI pressure transducer (can be purchased under PN 554-102). If these are not connected to a pressure transducer, the Fuel and Oil Pressure will read "LEr" on the hand-held display. This will not cause any issues. Connect to the transducer (if installed).



Figure 20 Fuel



Figure 21 Oil

12.3.8 CANbus – Handheld (CAN)

The handheld controller is used for create of an initial calibration for the system, allows for simple tuning changes to be performed, and is also used to view various information of the EFI system. It should be installed such the handheld controller can be easily used in the passenger compartment. The handheld has two loose wires and one connector with orange wires. Plug the connector into the main wiring harness into the plug marked “CAN”. This plug is located about 8 inches from the ECU connector. The handheld controller also has a white and a black wire. The black wire should be run to a sound vehicle ground. The white wire should be connected to a +12 volt source switched ignition source. The handheld does not have to be powered/installed after the vehicle is up set up and running properly.

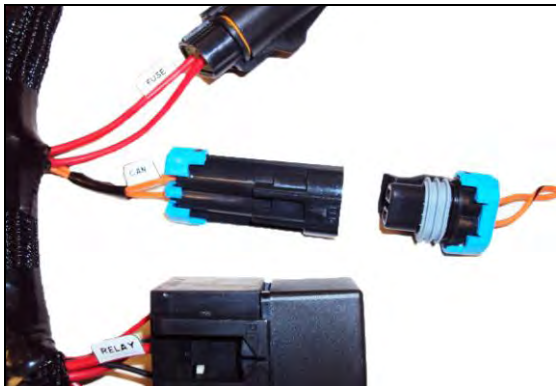

Figure 22 Harness to Handheld



Figure 23 Handheld

12.3.9 Knock Sensor (Knock)

The knock sensor connector is NOT used on Avenger systems.



Figure 24 Knock

12.3.10 Ignition (IGN) –

There is a 10 pin connector marked “IGN”. This is to connect to various ignition systems. This is not required for some applications. See section 16.0 below for proper ignition wiring.

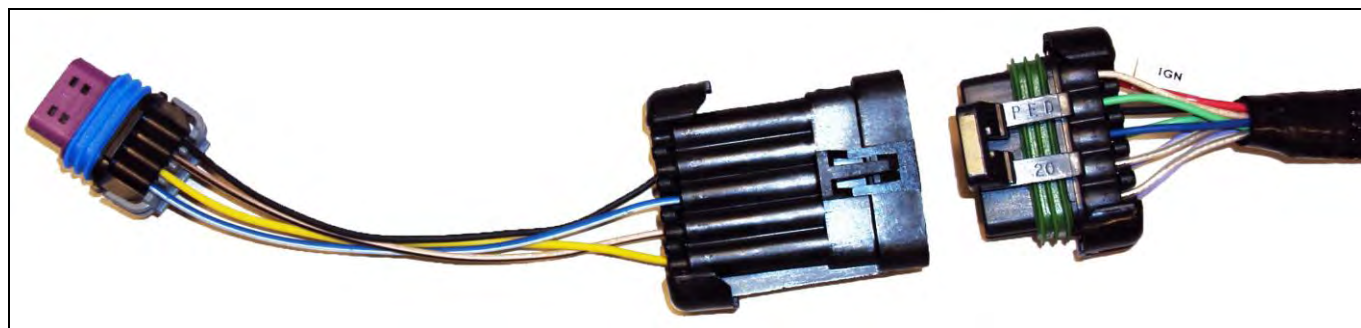

Figure 25 IGN

13.0 PRIMARY OUTPUTS

13.1 Idle Air Control (IAC)

Connect to the idle air control motor which is installed in the throttle body.

13.2 Fuel Injector Outputs (INJ)

Connect the fuel injector harness on the TBI unit to the injector connector on the main harness.

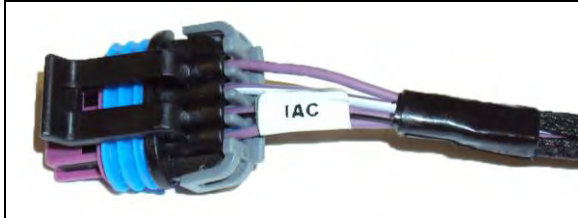

Figure 26 IAC

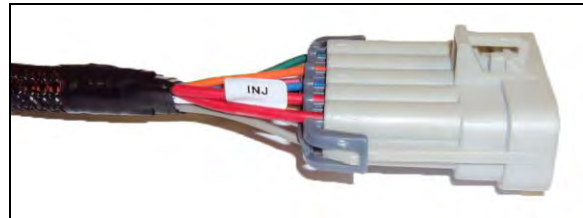

Figure 27 INJ

14.0 LOOSE WIRES

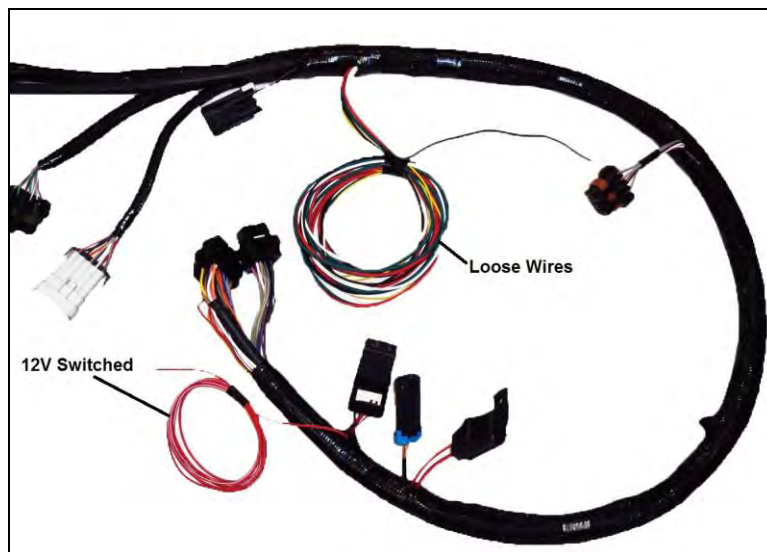

Figure 28

The following loose wires in the main wiring harness should be connected as follows on all systems. All of these wires come out of the harness about 40" from the ECU connectors except for the "12V Switched" wire.

12V Switched – Color = Red/White – Should be connected to a clean +12 volt power source. Power source should only be active when the ignition is on. Make sure source has power when engine is cranking as well (check with voltmeter). Not all sources apply power when the ignition switch is in "cranking" position. This wire is located approximately 7" from the ECU connectors. **Refer to Figure 24.**

12V Battery – Color = Red – Should be connected directly to the battery. This powers the fuel pump and fuel injectors. This wire is protected by a fuse in a sealed fuse holder. The fuse holder is located about 9" from the ECU connector. A fuse is pre-installed (20A).

12V Fuel Pump – Color = Green - Used to directly power a fuel pump (+12 volt). Do not use this wire to power fuel pumps that require over 10-12 Amps. For high current pumps, use this wire to trigger a separate relay and use larger gauge wire to feed the pump - 10 gauge is recommended. The pump that include with Avenger systems draws less than 10 Amps and can be powered directly by this wire.

The fuel pump also requires a ground wire. Run a wire from the negative side of the fuel pump (marked "-" on the Holley pump in this kit). Connect it to a solid chassis/frame ground.



Figure 29

Points Output – Color = White – This wire is NOT used with the Avenger system. Tape up the end or install heat shrink in it.

Chassis Ground – Color = Black – Connect to a chassis ground point that has excellent connectivity with both the engine and the battery.

–Coil – – Color = Yellow – See section 15.0 below. This is an RPM input wire used for *some* applications.

15.0 IGNITION/ENGINE SPEED INPUT

The most important signal for the ECU is the Engine Speed input. It is critical that this is configured and wired correctly or poor performance will result.

There are 3 engine speed options on the Avenger systems. Each one is wired differently. If these are wired incorrectly, it is easily possible to permanently damage the ECU so pay close attention to proper wiring. These options are described below and wiring diagrams are supplied below the descriptions:

OPTION 1) –Coil —engine speed input – Use this if:

- You are using a stock type mechanical advance distributor with a stock inductive ignition coil. Examples of this would be any older style points distributor, a 1974-1981 GM large cap HEI.
- Do NOT use this input if you are using an aftermarket Capacitive Discharge (CD) ignition system such as a MSD, Mallory, or others. The ECU will be damaged if you connect to a capacitive discharge type ignition coil.

NOTE: Using this input, the EFI will NOT control the ignition timing of the engine. The timing will be based on the distributor initial, mechanical, and vacuum advance, just like it did with a carburetor.

OPTION 2) –Tach Out” engine speed input -

- If you are using an aftermarket Capacitive Discharge (CD) ignition system such as a MSD, Mallory, or others, you need to connect to the “Tach Out” connection or wire these systems provide. This is a 12 volt square wave output.

CAUTION! NEVER, NEVER connect any of the EFI wires to the coil on any CD type ignition system. The ECU will be permanently damaged!

NOTE: Using this input, the EFI will NOT control the ignition timing of the engine. The timing will be based on the distributor initial, mechanical, and vacuum advance, just like it did with a carburetor.

OPTION 3) –GM Small Cap HEI” Computer Controlled Distributor –

- Small and Big Block Chevy engines can use a small cap GM HEI computer controlled distributor that was available on factory GM vehicles from the 1980’s through mid 1990’s. This distributor provides an engine speed signal to the EFI, as well as allowing the EFI to control the ignition timing.

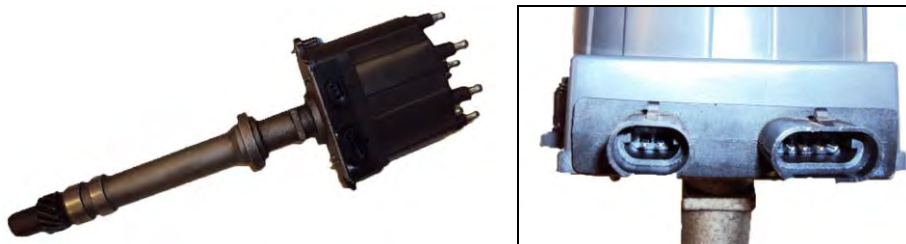

Figure 30 Distributor and Close Up of Distributor

16.0 WIRING

OPTION 1 – Coil — Option one uses the “Yellow Wire” for engine speed input. The yellow wire is a loose wire located 40” from the ECU connectors. It is bundled with several other loose wires. The following two diagrams show how to wire to the two most common applications which are:

- 1) Any General Motors engine equipped with a factory large cap HEI distributor equipped with mechanical/vacuum advance (Figure 31).
- 2) Any engine equipped with a factory mechanical advance distributor and separate canister style coil. This would include any points style distributor (Figure 32).

Figure 31 below shows how to connect to a large cap HEI distributor.

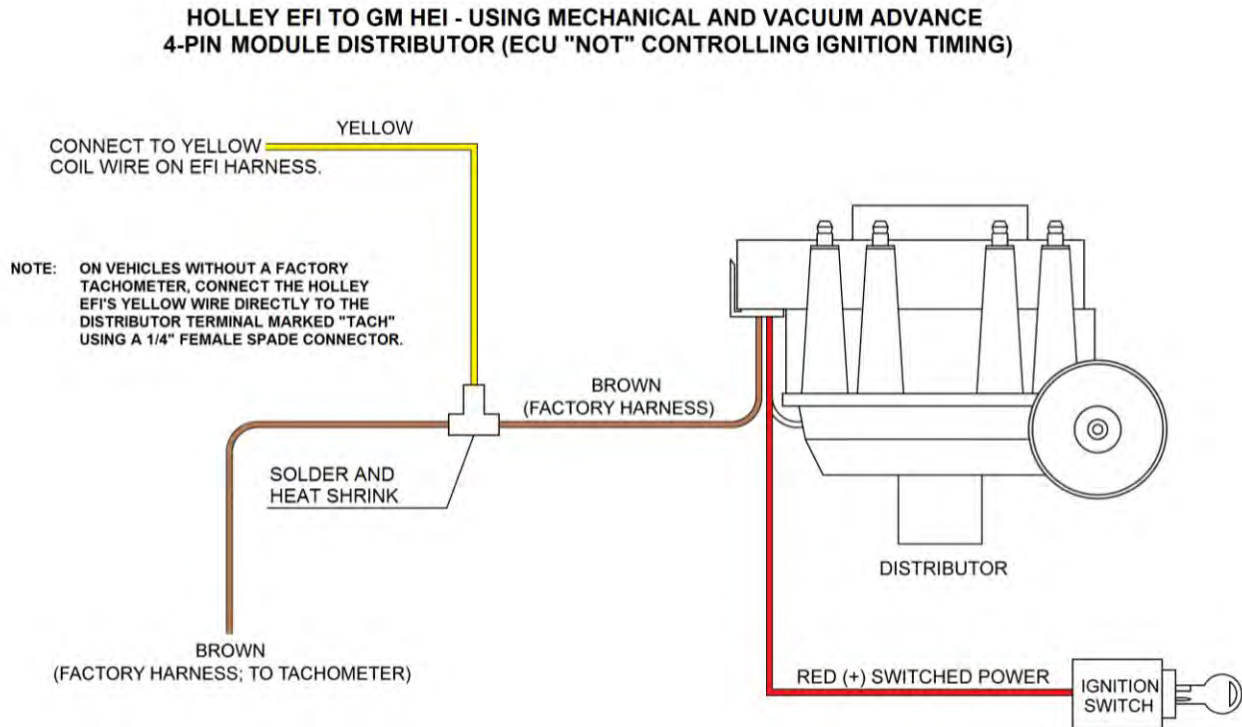

Figure 31

Figure 32 below shows how to connect to a factory style ignition with a canister style coil.

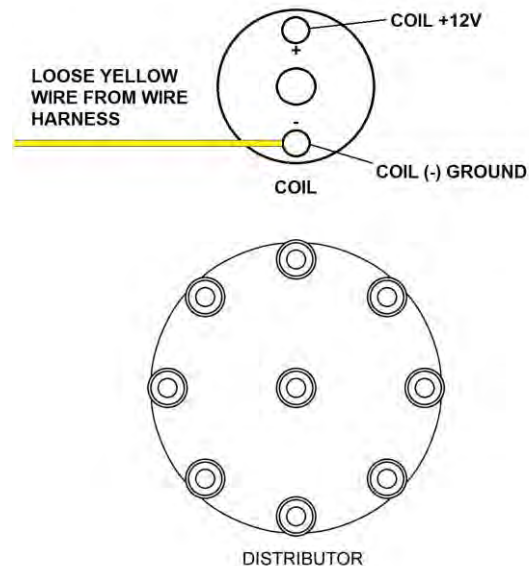

Figure 32

OPTION 2 – ‘Tach Out’ – If using an aftermarket Capacitive Discharge (CD) ignition system, you need to connect to the “Tachometer Output” connection on the ignition box. To do so, you need to install the included ignition adapter that comes with your kit. This adapter will have a single “yellow/black” wire (yellow wire with a black stripe) that you will connect to the tach out on the ignition box. This output usually is typically a spade type connector on the side of the box, or a wire coming out of the box. This adapter looks like this:

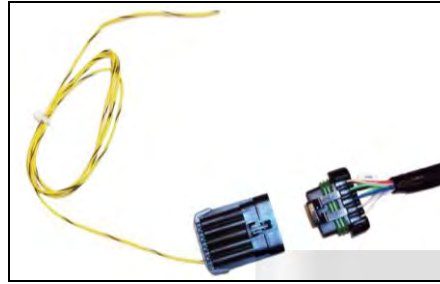

Figure 33

Connect it to the main EFI harness to the connector marked “IGN” (Ignition). Connect the yellow/black wire to the “tach out” connection on your ignition box. If you don’t know what wire this is, contact the tech service department for the ignition system you purchased.



Figure 34

OPTION 3 – ‘GM Small Cap HEI’ Computer Controlled Distributor – An ignition adapter to connect to a computer controlled small cap HEI distributor is included with all Small and Big Block Chevy multi-port Avenger EFI kits. This adapter looks like:

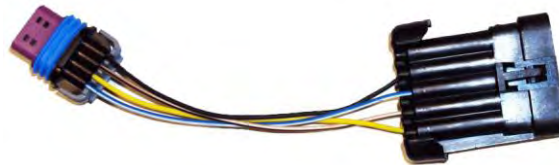

Figure 35

Connect this adapter to the main EFI harness to the connector marked “IGN” (Ignition). Connect the other end to the 4 pin connector on the HEI distributor. You will need to supply the wiring to connect the distributor to the coil.

Figure 36 shows how to wire when NOT using an aftermarket CD box. Figure 37 Shows how to wire when using an aftermarket CD box.

HOLLEY EFI TO GM HEI IGNITION - USING COMPUTER CONTROLLED DISTRIBUTOR, EXTERNAL COIL (ECU CONTROLLING TIMING)

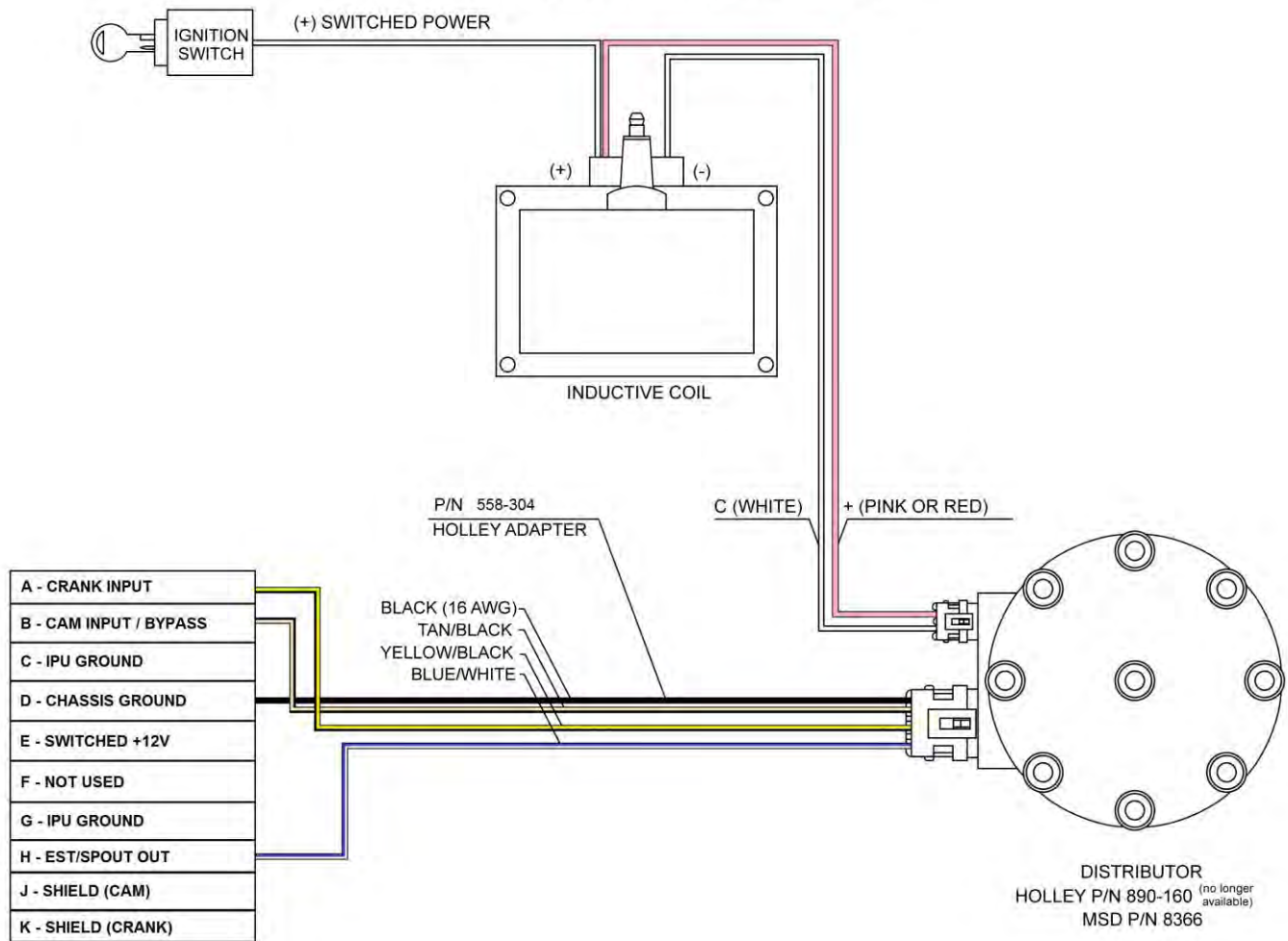

Figure 36

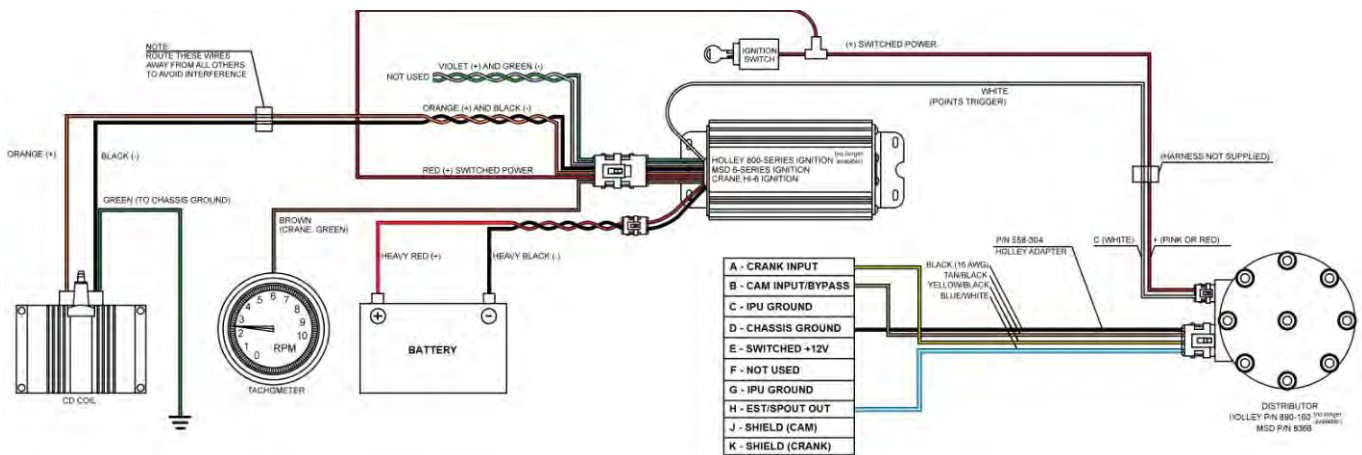

Figure 37

17.0 ADDITIONAL OUTPUTS

There are 3 optional outputs available on the system that can be use for the following features:

- Air Conditioning Shutdown at wide open throttle
- Electric Fan #1 output
- Electric Fan #2 output

These outputs are located in the "Input/Output" connector. This connector is located about 27 inches from the ECU connector and contains 8 pins. 3 of these are used for the features mentioned above. A harness is available to plug into this connector under Holley PN 558-400 that provides a mating plug in connector and additional harness length. If you wish to not purchase this mating harness, but want to use these options, you can remove a single wire from the main harness Input/Output connector and solder an additional length of wire on for the features you wish to use.

The following indicates proper wiring for these features.

A/C Shutdown – This output will provide a +12 volt output a defined throttle position. This output can be used to trigger a relay that deactivates the A/C at higher throttle positions. This may require the installation of a 5 pole relay in the existing A/C wiring. This wire is located in pin E of the 8 pin Input/Output connector and is Grey with a Yellow stripe.

Electric Fan #1 output – This output will provide a ground output to trigger a relay used for a cooling fan. This output should never be directly connected to a fan, but the relay that powers the fan. It should be connected to the ground trigger of the relay. This wire is located in pin G of the 8 pin Input/Output connector and is Grey with a Black stripe.

Electric Fan #2 output – This output will provide a ground output to trigger a relay used for a cooling fan. This output should never be directly connected to a fan, but the relay that powers the fan. It should be connected to the ground trigger of the relay. This wire is located in pin G of the 8 pin Input/Output connector and is Grey with a Green stripe.

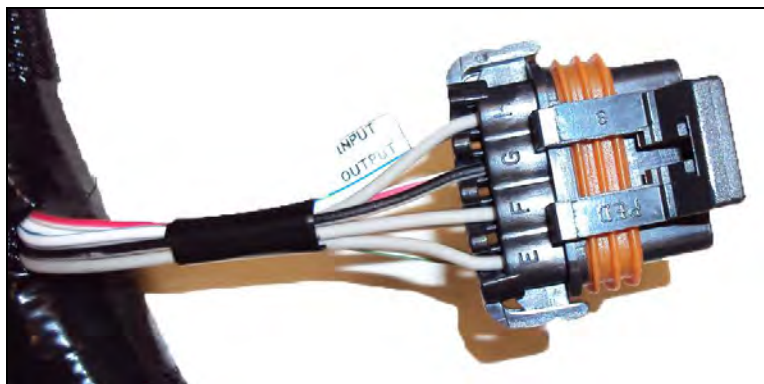

Figure 38

APPENDIX 1.0

Pinout

The following shows pins that are used on Avenger systems. Pins that are not used on Avenger systems, but may have wires populated in the harness, are denoted with an asterisk (*).

P1A Connector

Pin	Function
A1	Coil – Input
A2	Fuel Pump Out (+12v) (10A Max)
A3	*
A4	*
A5	TPS Input
A6	*
A7	WB1 COMPR2
A8	WB1 Shield
A9	WB HTR -
A10	Switched +12v Input
A11	Manifold Air Temp Input
A12	*
A13	*
A14	Cam/Crank Ground
A15	Gauge Digital Output
A16	WB1 COMPR1
A17	WB1 VS-/IP+
A18	Sensor Ground
A19	Engine Coolant Temp Input
A20	Oil Pressure Input
A21	*
A22	Cam Sync Input / Ignition Bypass Output
A23	Map Sensor Input
A24	CAN Lo
A25	WB1 VS+
A26	Sensor +5v
A27	NOT USED
A28	EST/Spout Output
A29	*
A30	Crank Speed Input
A31	Fuel Pressure Input
A32	CAN Hi
A33	WB1 IP+
A34	WB HTR +

P1B Connector

Pin	Function
B1	IAC A Lo
B2	IAC A Hi
B3	Fan #2 Output (ground)
B4	Injector F Output
B5	Injector G Output
B6	Injector H Output
B7	Injector E Output
B8	IAC B Lo
B9	IAC B Hi
B10	Fan #1 Output (ground)
B11	*
B12	A/C Shutdown (+12v)
B13	Injector D Output
B14	*
B15	*
B16	*
B17	*
B18	*
B19	Injector A Output
B20	EST 12V Output
B21	*
B22	*
B23	*
B24	*
B25	Injector C Output
B26	Injector B Output



**Holley Technical Support
1801 Russellville Road
Bowling Green, KY 42101**

Phone: 1-270-781-9741

Fax: 1-270-781-9772

**For online help, please refer to the Tech
Service section of our website:**

www.holley.com

271R998A HOLLEY EFI 2BBL TBI HARNESS

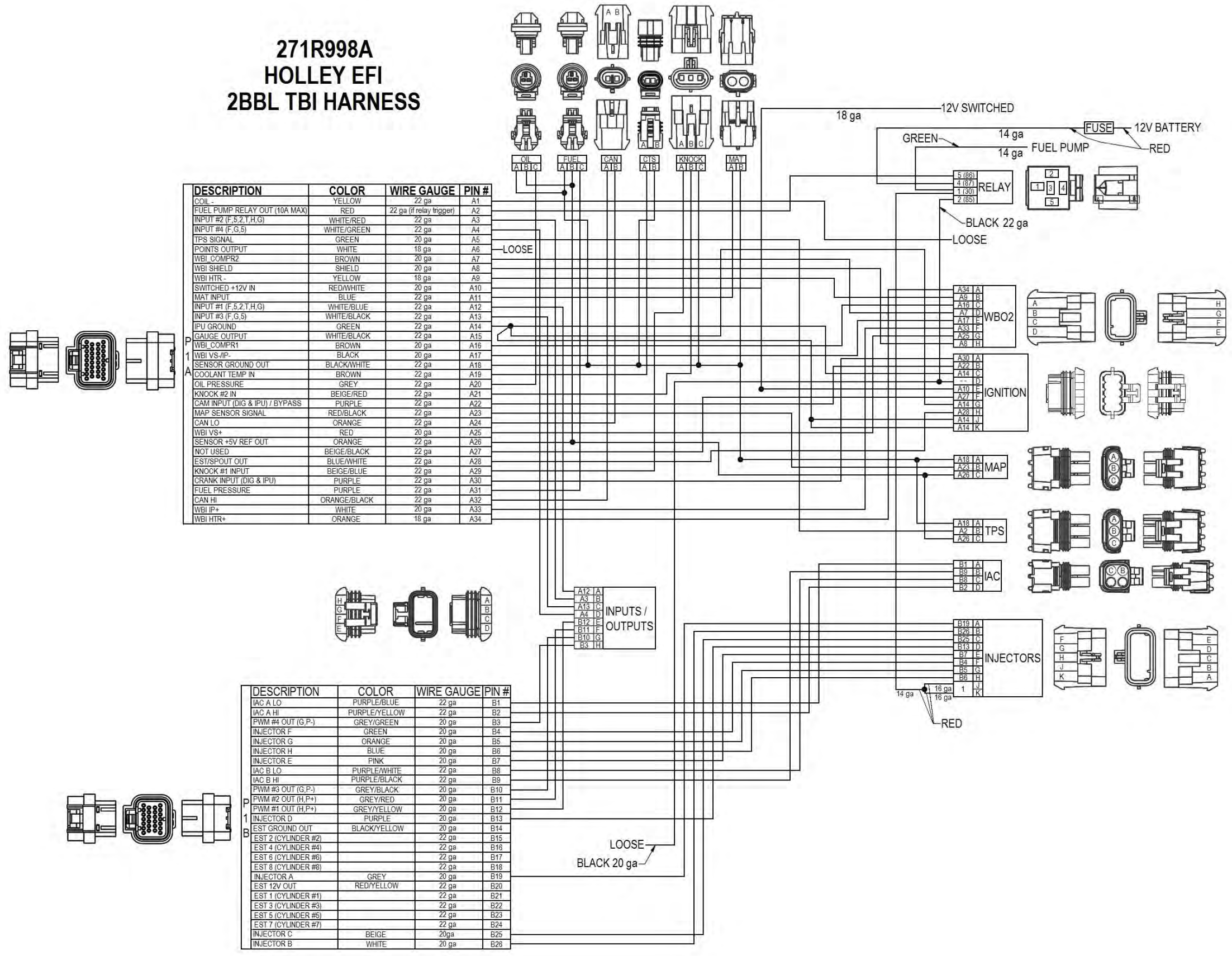

DESCRIPTION	COLOR	WIRE GAUGE	PIN #
COIL -	YELLOW	22 ga	A1
FUEL PUMP RELAY OUT (10A MAX)	RED	22 ga (if relay trigger)	A2
INPUT #2 (F, S, 2, T, H, G)	WHITE/RED	22 ga	A3
INPUT #4 (F, G, S)	WHITE/GREEN	22 ga	A4
TPS SIGNAL	GREEN	20 ga	A5
POINTS OUTPUT	WHITE	18 ga	A6
WBI COMPR2	BROWN	20 ga	A7
WBI SHIELD	SHIELD	20 ga	A8
WBI HTR	YELLOW	18 ga	A9
SWITCHED +12V IN	RED/WHITE	20 ga	A10
MAT INPUT	BLUE	22 ga	A11
INPUT #1 (F, S, 2, T, H, G)	WHITE/BLUE	22 ga	A12
INPUT #3 (F, G, S)	WHITE/BLACK	22 ga	A13
IPU GROUND	GREEN	22 ga	A14
GAUGE OUTPUT	WHITE/BLACK	22 ga	A15
WBI COMPR1	BROWN	20 ga	A16
WBI VS /IP-	BLACK	20 ga	A17
SENSOR GROUND OUT	BLACK/WHITE	22 ga	A18
COOLANT TEMP IN	BROWN	22 ga	A19
OIL PRESSURE	GREY	22 ga	A20
KNOCK #2 IN	BEIGE/RED	22 ga	A21
CAM INPUT (DIG & IPU) / BYPASS	PURPLE	22 ga	A22
MAP SENSOR SIGNAL	RED/BLACK	22 ga	A23
CAN LO	ORANGE	22 ga	A24
WBI VS+	RED	20 ga	A25
SENSOR +5V REF OUT	ORANGE	22 ga	A26
NOT USED	BEIGE/BLACK	22 ga	A27
EST/SPOUT OUT	BLUE/WHITE	22 ga	A28
KNOCK #1 INPUT	BEIGE/BLUE	22 ga	A29
CRANK INPUT (DIG & IPU)	PURPLE	22 ga	A30
FUEL PRESSURE	PURPLE	22 ga	A31
CAN HI	ORANGE/BLACK	22 ga	A32
WBI IP+	WHITE	20 ga	A33
WBI HTR+	ORANGE	18 ga	A34

DESCRIPTION	COLOR	WIRE GAUGE	PIN #
IAC A LO	PURPLE/BLUE	22 ga	B1
IAC A HI	PURPLE/YELLOW	22 ga	B2
PWM #4 OUT (G.P.)	GREY/GREEN	20 ga	B3
INJECTOR F	GREEN	20 ga	B4
INJECTOR G	ORANGE	20 ga	B5
INJECTOR H	BLUE	20 ga	B6
INJECTOR E	PINK	20 ga	B7
IAC B LO	PURPLE/WHITE	22 ga	B8
IAC B HI	PURPLE/BLACK	22 ga	B9
PWM #3 OUT (G.P.)	GREY/BLACK	20 ga	B10
PWM #2 OUT (H.P+)	GREY/RED	20 ga	B11
PWM #1 OUT (H.P+)	GREY/YELLOW	20 ga	B12
INJECTOR D	PURPLE	20 ga	B13
EST GROUND OUT	BLACK/YELLOW	20 ga	B14
EST 2 (CYLINDER #2)		22 ga	B15
EST 4 (CYLINDER #4)		22 ga	B16
EST 6 (CYLINDER #6)		22 ga	B17
EST 8 (CYLINDER #8)		22 ga	B18
INJECTOR A	GREY	20 ga	B19
EST 12V OUT	RED/YELLOW	22 ga	B20
EST 1 (CYLINDER #1)		22 ga	B21
EST 3 (CYLINDER #3)		22 ga	B22
EST 5 (CYLINDER #5)		22 ga	B23
EST 7 (CYLINDER #7)		22 ga	B24
INJECTOR C	BEIGE	20 ga	B25
INJECTOR B	WHITE	20 ga	B26

271R998A HOLLEY EFI 2BBL TBI HARNESS

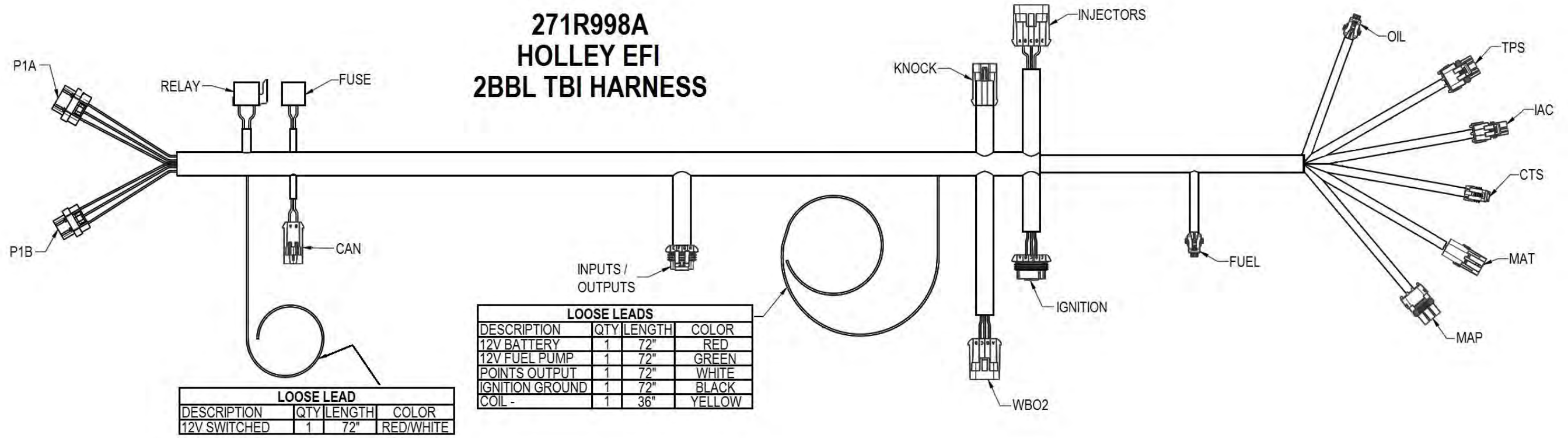

LOOSE LEAD			
DESCRIPTION	QTY	LENGTH	COLOR
12V SWITCHED	1	72"	RED/WHITE

LOOSE LEADS			
DESCRIPTION	QTY	LENGTH	COLOR
12V BATTERY	1	72"	RED
12V FUEL PUMP	1	72"	GREEN
POINTS OUTPUT	1	72"	WHITE
IGNITION GROUND	1	72"	BLACK
COIL -	1	36"	YELLOW