

HP EFI

ENGINE MANAGEMENT SYSTEM



HP EFI

UNIVERSAL RETROFIT KITS

550-500 (HP Universal Retrofit Kit for 4150™ carb style intakes)

550-501 (HP Universal Retrofit Kit for 4500™ carb style intakes)

INSTALLATION INSTRUCTIONS

199R10510

NOTE: These instructions must be read and fully understood before beginning installation. If this manual is not fully understood, installation should not be attempted. Failure to follow these instructions may result in subsequent system failure.

TABLE OF CONTENTS

1.0 OVERVIEW.....	3
2.0 SKILLS AND EQUIPMENT REQUIRED.....	3
3.0 COMPONENTS REQUIRED FOR INSTALLATION.....	3
4.0 INTAKE MANIFOLD SELECTION.....	3
5.0 INJECTOR BUNG INSTALLATION.....	4
6.0 FUEL RAIL MACHINING.....	4
7.0 INJECTOR BUNG INSTALLATION AND FUEL RAIL MOUNTING.....	5
8.0 FUEL SYSTEM DESIGN.....	5
8.1 Fuel Pump.....	5
8.2 Fuel Injectors.....	6
8.3 Fuel Filters.....	7
9.0 VACUUM LINES.....	7
10.0 PLUMBING.....	7
10.1 Fuel Line Sizes.....	8
11.0 THROTTLE BODY INSTALLATION.....	8
12.0 OXYGEN SENSOR INSTALLATION.....	9
12.1 Oxygen Sensor Mounting Procedure.....	9
13.0 LIST OF ACCESSORIES.....	9
14.0 WIRING.....	12
14.1 Important Wiring “Do’s and Don’ts”.....	12
15.0 ECU CONNECTORS AND PINOUT.....	12
15.1 Pinout.....	13
16.0 PRIMARY SENSORS CONNECTION.....	14
16.1 Throttle Position Sensor (TPS).....	14
16.2 Manifold Air Pressure Sensor (MAP).....	14
16.3 Coolant Temperature Sensor (CTS).....	14
16.4 Manifold Air Temperature Sensor (MAT).....	14
16.5 Knock Sensor (Knock).....	14
16.6 Wide Band Oxygen Sensor (WB02).....	14
16.7 Fuel Pressure (Fuel).....	14
16.8 Oil Pressure (Oil).....	14
16.9 CANbus (CAN).....	14
17.0 PRIMARY OUTPUTS.....	15
17.1 Idle Air Control (IAC).....	15
17.2 Fuel Injector Outputs (Injectors).....	15
17.3 Ignition Adapter (Ignition).....	15
18.0 LOOSE WIRES.....	15
19.0 MAIN POWER HARNESS.....	16
20.0 IGNITION SYSTEM WIRING.....	16
20.1 Small Cap Computer Controlled GM HEI.....	16
20.2 NON- ECU Controlled Timing Applications (ex. GM Non-ECU Controlled Large Cap HEI).....	17
20.3 Magnetic Crank Pickup.....	19
20.4 Magnetic Cam Pickup.....	20
20.5 Hall Effect Crank Pickup.....	20
20.6 Hall Effect Cam Pickup.....	21
21.0 PROGRAMMABLE INPUTS AND OUTPUTS.....	21
21.1 Inputs.....	22
21.2 Outputs.....	23

1.0 OVERVIEW

The **HP EFI** Universal Retrofit Kits (P/N 550-500 & 550-501) are designed for engines that have no off-the-shelf port fuel injection manifold available. It comes with almost all the components necessary for complete installation. Other components required are listed in this manual with guidelines for them.

2.0 SKILLS AND EQUIPMENT REQUIRED

Various skills and tools are required for the complete installation and successful use of this kit. Machining for the fuel injector bungs and fuel rails requires the use of a Bridgeport mill or similar piece of machining equipment. It is nice to have a digital X/Y axis readout. The injector bungs ideally should be TIG-welded to the intake manifold, which requires an experienced aluminum TIG-welder. They can also successfully be epoxied, but welding will guarantee good durability. The fuel rails will also require tapping and/or machining depending upon the fittings chosen. Hold-downs for the fuel rails will also have to be fabricated. These should be welded to the manifold, but they can be designed to be bolted down.

The tuning of the fuel injection system requires that an individual have basic computer and engine tuning skills. A manual is included that includes detailed and comprehensive tuning instructions.

NOTE: This kit is a universal kit. The level of skill and fabrication required will vary for every application.

3.0 COMPONENTS REQUIRED FOR INSTALLATION

The following components are not included with this kit and are necessary to complete the installation of an EFI system. Any of these components that are available from Holley can be found at the end of this manual under "List of Accessories".

- Intake Manifold for Specific Application (see comments in the manual)
- Fuel Pump (needs to be sized to application, see guidelines in this manual)
- Fuel Injectors (needs to be sized to application, see guidelines in this manual)
- Various Fasteners
- Material to Fabricate Fuel Rail Hold-Downs
- Plumbing
- 30-100 Micron Coarse Fuel Filter (before the fuel pump)
- 10 Micron High-Pressure EFI Fuel Filter (after the fuel pump)
- Throttle Linkage

4.0 INTAKE MANIFOLD SELECTION

This kit is designed to retrofit Multi-port electronic fuel injection on an intake manifold that is designed for a carburetor. The throttle body included is designed for a square bore 4150 manifold (PN 550-500) or a Dominator flange manifold (PN 550-501). If a different flange is used, an adapter will be necessary.

The easiest style of manifold to convert is a single-plane type intake manifold. A single plane intake manifold is not recommended with mild engines with carburetors, as they usually experience a loss in low-speed torque. Some of this is due to a poor vacuum signal to the carburetor. This is not a problem with EFI, as the EFI is programmable and the proper amount of fuel is easily programmable.

A dual-plane intake manifold has longer runners that enhance lower RPM torque. However, it is difficult and usually impossible to use a solid length fuel rail with a dual plane intake.

Testing has shown that EFI overcomes much of the typical loss in low RPM torque that usually occurs with a carburetor and a single plane intake.

5.0 INJECTOR BUNG INSTALLATION

It is critical that the injector bungs be installed correctly to ensure proper injector alignment. The following list must be considered before any machining starts:

- Fuel rail clearance with respect to:
 - Alternator, air conditioning, and other accessories
 - Rail to Throttle Body Clearance (It is very important to check throttle body linkage to rail clearance.)
 - Rear fitting clearance with firewall
 - Distributor
 - Valve cover clearance
- Clearance with any throttle cable and transmission cable brackets
- Injector angle. Ideally the injector should point towards the intake valve. This is not possible or easy to do most of the time. Having the fuel injectors vertical (with respect to the ground) is acceptable and allows for the simplest machining. The steeper the angle of the intake manifold runner, the more difficult it becomes to maintain a good angle.
- Position the injector bung, so that the bungs won't protrude through the intake manifold reducing airflow. This is constrained by the lower injector o-rings. They must be contained by the bung. The bungs WILL have to be ground down, as they are intentionally extra long.

WARNING: If the bottom injector o-rings are not contained by the bung and do not seal, you will have a vacuum leak that will cause major tuning problems.

- Generally the injectors are centered in the port for best injector spray and atomization

1. Determine positions for the injector bungs, keeping the information above in mind. It is best to mount the throttle body and as many other items as possible when doing this to eliminate future clearance problems
2. After the positions are determined, fixture the intake manifold on a milling machine. Make sure the intake is level and positioned straight. Machine holes, so that ideally a slight press fit (.0005-.001") is achieved with the bung. This will make it easier when welding or epoxying the bung in. Record the center-to-center dimension of the injector bungs. They will be needed when machining the fuel rails. The bungs will be attached after the fuel rails are machined.

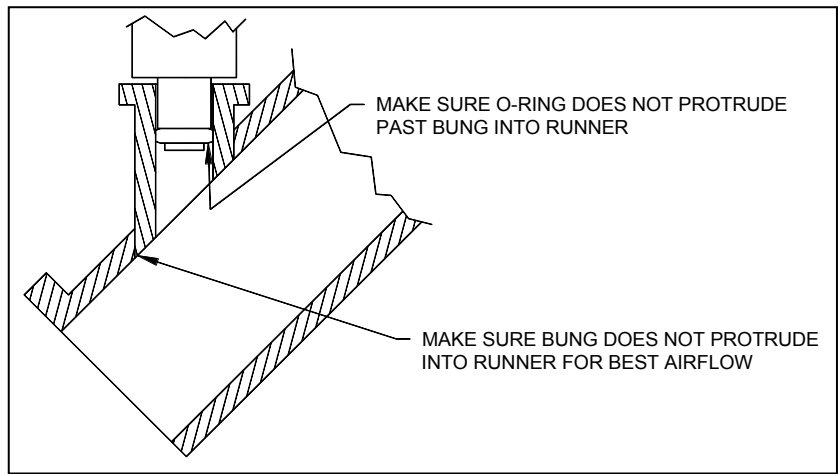

6.0 FUEL RAIL MACHINING

NOTE: See the Figures 6 - 8 for fuel rail machining drawings.

Once the manifold is machined, the fuel rails can be machined next.

1. If the rails need to be shortened, perform this task first. The rails included are extra long for any application and will likely need to be shortened. The length will depend on injector spacing, fittings, and the crossover-line design used.
2. Mount the rail in the Bridgeport and square it up.
3. Select a starting point for the first hole.
4. Determine the proper diameter for the injectors you are using. For Holley injectors, machine the hole to a diameter of .535 inches (See Figure 6 in the back). The bore must be smooth for the injector o-ring surface, or leaks will result.
5. If this bore diameter is machined completely through, injector-retaining clips must be used, so that the injector o-ring does not protrude through and cause a leak. The retaining clip is not needed if a step is machined in the bottom of the injector bore in the fuel rail, so that the o-ring can not protrude into the passage.

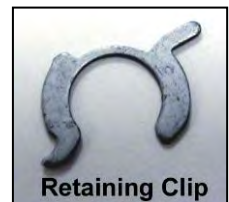

6. Using the exact same dimensions that you machined the intake manifold, machine the injector holes in the fuel rails.
7. The ends of the rails must then be machined, so that a fitting can be installed. There are generally two methods to do this. These methods are: 1) an AN thread and an o-ring 2) or tapping the ends to an NPT thread.
 - (1) The AN thread and o-ring seal is the preferred method, although more complicated to machine. The AN thread uses the o-ring to seal. The drawings at the end show the proper machining for this method (See Figure 8 in the back).
 - (2) The second would be to use a NPT thread. The rail must be drilled to the proper drill size for the tap first. Then tap per specifications.

7.0 INJECTOR BUNG INSTALLATION AND FUEL RAIL MOUNTING

1. After the manifold and rails are machined, the injector bungs need to be welded or epoxied and the hold-downs for the fuel rails must be attached. The recommended method is TIG-welding. This ensures a safe and long-lasting part. However, a person experienced with aluminum TIG-welding must perform this operation. Epoxying the bungs is acceptable, but is not advised on high-vibration race engines or for used intake manifolds.
2. The bungs can either be welded in from the bottom or on the top. Welding on the bottom provides a cleaner look. If this is done, the bungs should be pre-machined, so that they are flush with the inside of the manifold runner. If they aren't they can't be welded easily. If they are welded from the top, the bung can be ground off flush in the intake manifold runner after they are welded. If they are epoxied they should be ground to fit inside of the runner first.

WARNING! Do not perform any welding with the injectors in the bungs, as the heat will damage them.

3. The fuel rail hold-downs must be designed to keep the fuel rails stable and in place. The best method is to weld them to the manifold.
4. The fuel rails will then bolt to the fuel rail hold-downs. The rails will have to be machined for the fastener type used.



Figure 2

WARNING! EFI systems are run at high pressures. Make sure that the hold-down design securely fastens the fuel rails. If they don't, leaks and potential fire hazards can occur.

8.0 FUEL SYSTEM DESIGN

Several main components, not included with this kit, are the fuel injectors, fuel pump, and fuel filters. Proper selection of these components is critical to proper system operation. Engine horsepower and intended application are the critical variable in selecting these items.

8.1 Fuel Pump

The fuel pump must be selected to flow enough fuel and maintain the desired pressure. It is important to understand that with any fuel pump, as pressure is increased, flow decreases. This is especially important with EFI systems that operate from 40 to 60+ PSI.

Most fuel pumps are rated in gallons per hour. Gallons per hour (GPH) required can be calculated from the following equation:

$$(\text{Maximum Engine Horsepower}) \times (\text{Brake Specific Fuel Consumption}) / 6 \text{ lbs.} = \text{Minimum Pump GPH required}$$

Brake Specific Fuel Consumption (BSFC) is basically a measure of how much fuel is required for each HP produced. A lower number indicates that less fuel is needed for a given amount of power. High-compression race engines generally require less fuel than supercharged, turbocharged, and nitrous engines for the same HP.

The following are some BSFC number guidelines:

	BSFC
Naturally aspirated street engines:	.45-.55
Naturally aspirated race engines:	.4-.5
Supercharged, Turbo, and Nitrous engines:	.6-.65

Never size a pump to theoretical calculations. Pressure drop through lines and variations in pump tolerances require a safety margin. It is good to increase calculated pump size by about 30%.

Two Examples follow:

Example 1

950 Horsepower naturally aspirated race engine:
 $(950 \text{ HP}) \times (.42 \text{ BSFC})/6 = 66.5 \text{ GPH}$
Add the 30% margin
 $66.5 \times 1.3 = 86.45 \text{ GPH}$

Example 2

1,200 Turbocharged engine:
 $(1,200 \text{ HP}) \times (.63 \text{ BSFC})/6 = 126 \text{ GPH}$
Add the 30% margin
 $126 \times 1.3 = 163.8 \text{ GPH}$

As you can see, the BSFC has a significant role in an engine's fuel demand.

8.2 Fuel Injectors

Fuel injectors use some of the same variables as the fuel pump. Again, it is very important to size the injectors properly. Most fuel injectors are rated at about 43-45 PSI. For a complete list of injectors available, see the List of Accessories at the end of this manual.

The following formula is used to calculate the injector size needed:

Injector Size = Engine Horsepower x BSFC / # Cylinders x % Duty Cycle

Engine HP = Gross Flywheel HP
BSFC = Brake Specific Fuel Consumption, examples are given above with the fuel pump sizing
Cylinders = Number of cylinders if using Multi-port EFI and 1 injector per cylinder
% Duty Cycle = This number is used in the calculation so that the injector is not open 100% of the time (static) at peak power. Normally a number of 80%-90% is used.

Some examples follow:

Example 1

600 HP V8 street engine
 $600 \text{ HP} \times .5 \text{ BSFC} / 8 \times .9 \text{ duty cycle} = 42 \text{ lb./hr.}$

Example 2

900 HP naturally aspirated race engine
 $900 \text{ HP} \times .42 \text{ BSFC} / 8 \times .9 \text{ duty cycle} = 52.5 \text{ lb./hr.}$

Example 3

1200 HP Turbo-charged engine
 $1200 \text{ HP} \times .6 \text{ BSFC} / 8 \times .9 \text{ duty cycle} = 100 \text{ lb./hr.}$

You usually round the size up to the closest injector available. However, you can raise the fuel pressure to increase the flow of an injector. The following equation shows the formula to calculate injector flow when the pressure is increased:

New Flow = Rated Flow x square root (New Pressure/Rated Pressure)

Rated Flow = Flow the injector is rated at by the manufacturer
Rated Pressure = Flow the injector is rated at by the manufacturer (usually 43-45 PSI)
New Flow = Flow at new pressure
New Pressure = New pressure

Example:

An injector is rated at 30 lb./hr. at 45 PSI. Increasing the pressure to 55 psi results in the following flow:

$30 \times \text{square root } (55/45) = 33.2 \text{ lb./hr.}$

Increasing the fuel pressure will increase the fuel flow through the injectors.

Remember that although increasing pressure increases injector flow, it DECREASES fuel pump flow. Make sure the fuel pump has enough flow when the pressure is raised.

8.3 Fuel Filters

Fuel filters are an essential part for the life of the fuel pump and fuel injectors. Two fuel filters are required when running an in-line fuel pump. A coarse filter is required on the inlet of the fuel pump. This filter is generally 50-100 microns. A high-pressure EFI filter is required on the outlet of the fuel pump. These filters usually have about a 10 micron filtration rating.

Both filters must be sized for the flow of the particular application. Consult the filter manufacturer for specifications.

9.0 VACUUM LINES

There are two vacuum lines that should be connected for use with the fuel injection. Try to keep the vacuum lines, especially the MAP sensor line, as short as possible for best operation. Make sure there are no kinks in the lines. Use only a hose meant for vacuum and not pressure applications.

1. Connect a vacuum line from the MAP sensor to a vacuum port on the throttle body. Do not connect any other vacuum accessories to the MAP sensor port.
2. Connect a vacuum line from the fuel pressure reference port to a vacuum port on the throttle body. There are two small vacuum ports on the throttle body.

WARNING! The MAP sensor should be mounted upside down and at a higher level than the vacuum port it is connected to, so that condensation can not run into the sensor.

10.0 PLUMBING

Plumbing the EFI correctly is very important to proper operation. There are two basic ways that an EFI system can be plumbed with a V8 with a dual inlet remote regulator such as the one supplied with this kit. One is simpler and is recommended for lower HP applications. The second requires more plumbing, but is used at higher HP and fuel flow levels to ensure uniform fuel delivery.

The first method (see Figure 3) is recommended with engines that use 36 lb./hr. injectors and less. These engines are typically less than 600 HP. Fuel is fed into one rail. A crossover line links the first rail to the second. Fuel passes through the second rail. It then exits to the regulator into one of the two inlet ports on the side. The other inlet is plugged. The fuel returns to the tank through the bottom outlet port in the regulator.

The second method (see Figure 3) is recommended with engines with 42 lb./hr. and larger injectors. These engines are typically 600 HP and more. Engines with less power can also use this plumbing method. The main fuel inlet line is split, preferably with a "Y" type fitting into two lines before the fuel rail. Each line is routed to one bank of injectors. An outlet line from each rail is then routed to each regulator inlet port.

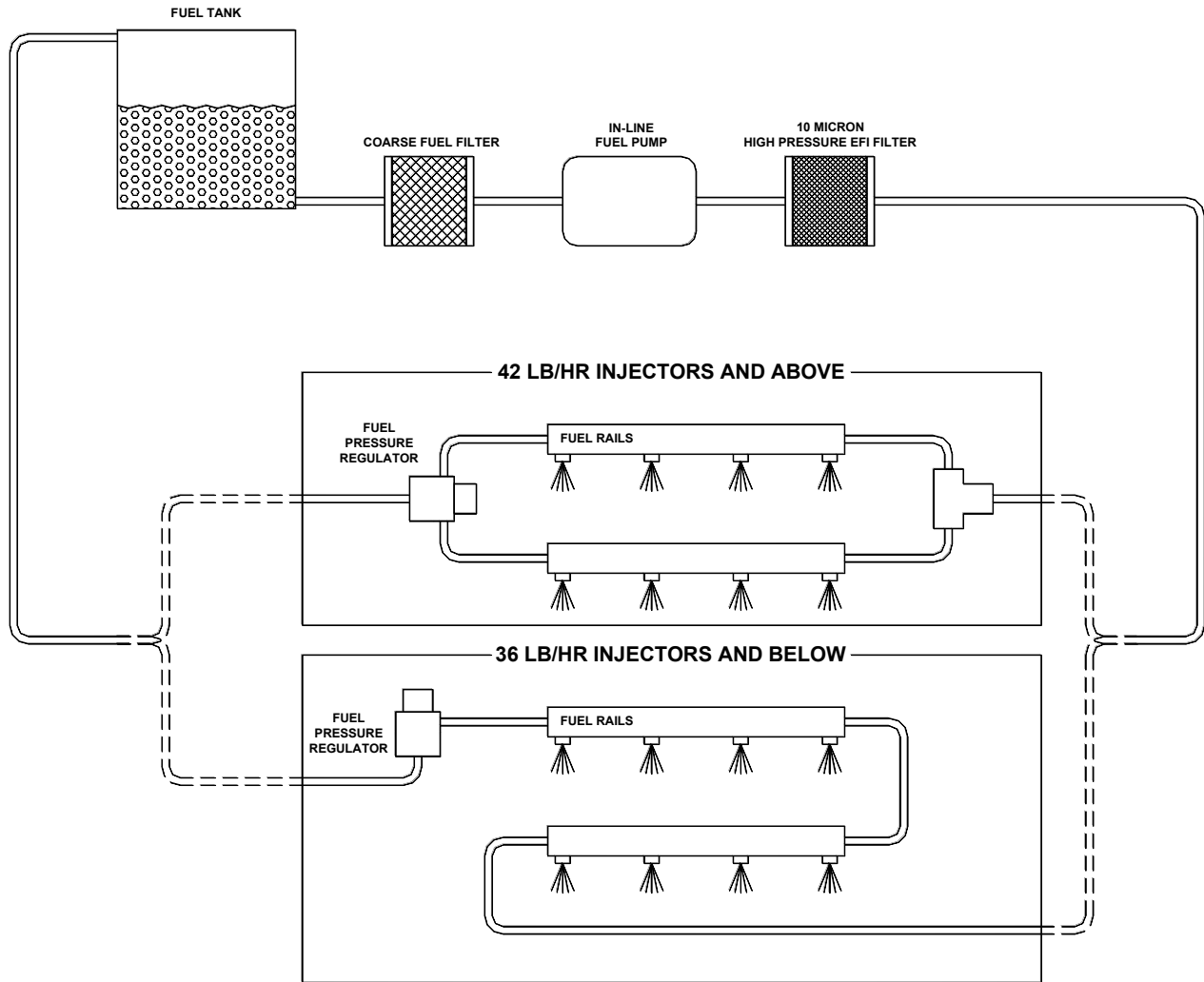

Figure 3

10.1 Fuel Line Sizes

Fuel line size is important with EFI, but there is a tendency to oversize feed lines. A high pressure EFI system does not need the same size lines as a low-pressure carbureted engine. A 3/8" diameter line (-6 AN) line is adequate for engines to at least 750 HP. This is a conservative number. A 1/2" diameter line (-8) line should be used on engines over 750 HP.

The regulator included with this kit includes -8 inlet fittings. The line used to go from the fuel rail(s) to the regulator should be -8 if these fittings are used. If different lines are desired, different fittings for the regulator need to be obtained. It is ok to use -8 lines to the regulator, but different sized inlet lines to the rails such as a -6.

If you need a fitting that has a -6 inlet for the regulator, purchase Earls PN 985068ERL.

The return fitting on the regulator has a -6 fitting. Use a 3/8" diameter return line for most applications.

NOTE: On very high horsepower applications (1000+ HP), follow the guidelines given by the fuel pump manufacturer for fuel system design.

11.0 THROTTLE BODY INSTALLATION

Your kit comes with either a 1000 or 2000 CFM throttle body. They fit 4150 and Dominator style flanges respectively. Both throttle body kits come with two gaskets and metal plate. These gaskets and plates should be used. Some manifolds do not have enough material in the back of the mounting pad to seal the IAC (idle air control) motor passages. If this occurs and the plates are not used, a vacuum leak will occur that will make tuning the engine impossible.

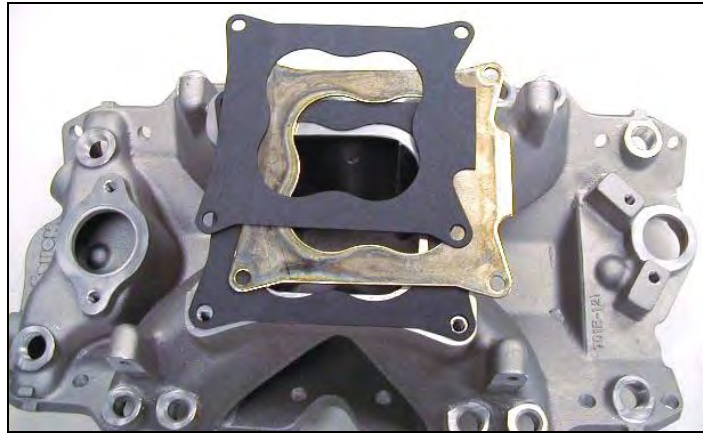

Figure 4

12.0 OXYGEN SENSOR INSTALLATION

12.1 Oxygen Sensor Mounting Procedure

NOTE: Someone should install the oxygen sensor boss that has experience welding exhaust systems. Any competent exhaust shop is able to perform this task at a minimal cost.

WARNING! Use of leaded fuels will degrade the oxygen sensor over time and will result in incorrect exhaust gas oxygen-content readings.

WARNING! Use of some RTV silicone sealers will destroy the oxygen sensor used with this product. Ensure that the RTV silicone sealant you use is compatible with oxygen sensor vehicles. This information should be found on the RTV package.

1. Locate a position for the oxygen sensor as close to the engine as possible. If your vehicle has catalytic converters, the oxygen sensor **MUST** be located between the engine and the catalytic converters. Good locations are in the drop pipe, or in the “Y” pipe on single exhaust systems. Pick a location that allows easy installation of the oxygen sensor, but will protect the sensor from road hazards.

NOTE: Vehicles with open exhaust systems will require at least 18-20” of pipe after the sensor to eliminate false readings resulting from atmospheric reversion. Even then, a false lean reading may occur at idle.

2. Drill a 7/8” hole in the location picked for the sensor. Weld the threaded boss into the 7/8” hole. An old spark plug with matching threads will avoid thread damage during the welding process. Weld all the way around the boss to insure a leak proof connection. Install the oxygen sensor into the threaded boss and tighten securely. It is a good idea to add anti-seize to the threads to aid in removal.
3. On vehicles equipped with an AIR pump, the oxygen sensor must be mounted before the AIR injection into the exhaust, or the AIR pump must be disconnected. Holley recommends that if the AIR is injected into both exhaust manifolds, mount the oxygen sensor into the pipe immediately after the exhaust manifold. Disconnect the AIR pump tube from the exhaust manifold and plug both ends. Check with local ordinances for the legality of this procedure in your area.

WARNING! Failure to disconnect the AIR pump or locating the oxygen sensor downstream from AIR injection will result in an extremely rich mixture which could cause driveability problems and severe engine damage.

13.0 LIST OF ACCESSORIES

The following is a list of products that can be used to complete the installation of you multi-port EFI system.

Plumbing Accessories – Earl's Performance Products has a complete product line of fittings and high performance hoses to plumb any EFI system. Please see the Earl's catalog or an Earl's dealer for a complete listing of components.

Fuel Pump – Holley PN 12-920 is an excellent in-line fuel pump for applications up to 700 HP at 50 PSI. This pump comes with 3/8” barbed hose fittings. PN 26-160 includes two –6 AN fittings for this pump. PN 26-180 includes two –8 AN fittings for this pump.

Throttle Cable Bracket – Holley PN 20-113 mounts to 1000 and 2000 CFM Holley throttle bodies and mounts both the throttle cable and 700R4 transmission TV cable.

MAP Sensor Bracket – Holley PN 9902-104 allows for the MAP sensor to be mounted using one of the throttle body bolts.

The following are a list of fuel injectors available. The packages include 8 injectors (ending in 8). For packages of 1, substitute a 1 for the last digit in the part number. All injector flows are rated at 43.5 PSI.

INJECTORS	
522-191	Single Injector 19 PPH
522-198	8 pack Injectors 19 PPH
522-241	Single Injector 24 PPH
522-248	8 pack Injectors 24 PPH
522-301	Single Injector 30 PPH
522-308	8 pack Injectors 30 PPH
522-361	Single Injector 36 PPH
522-368	8 pack Injectors 36 PPH
522-421	Single Injector 42 PPH
522-428	8 pack Injectors 42 PPH
522-481	Single Injector 48 PPH
522-488	8 pack Injectors 48 PPH
522-661	Single Injector 66 PPH
522-668	8 pack Injectors 66 PPH
522-831	Single Injector 83 PPH
522-838	8 pack Injectors 83 PPH
522-121	Single Injector 120 PPH
522-128	8 pack Injectors 120 PPH

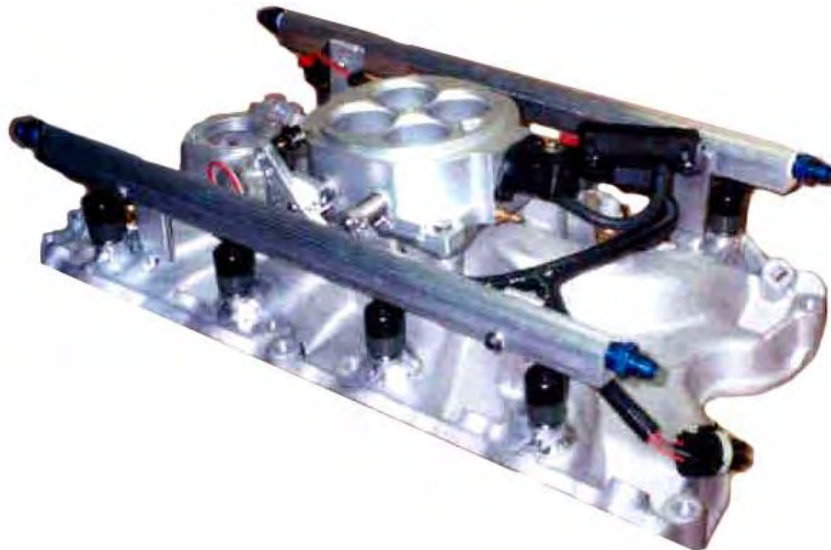

Figure 5—Example of Completed Manifold

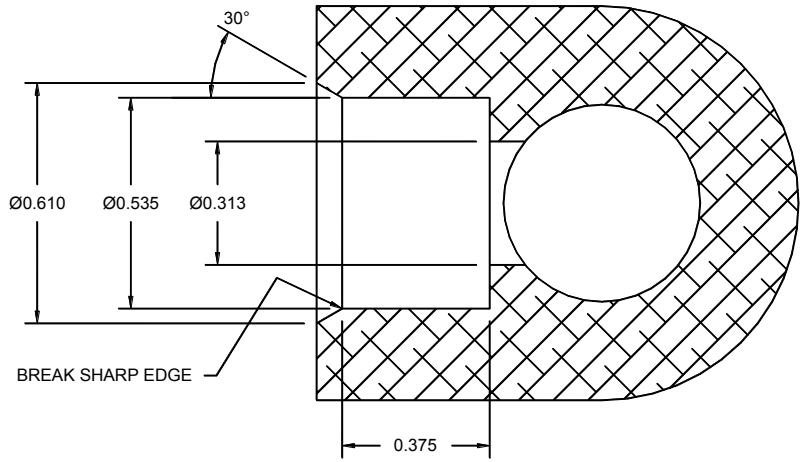

Figure 6

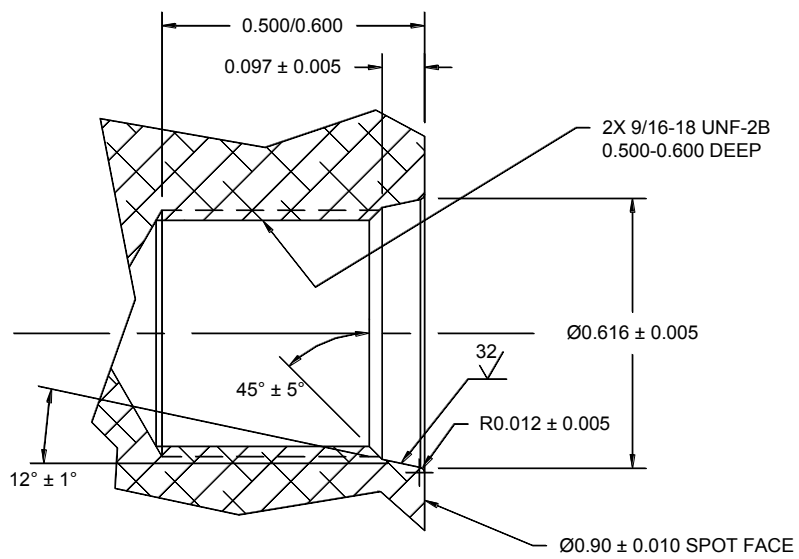
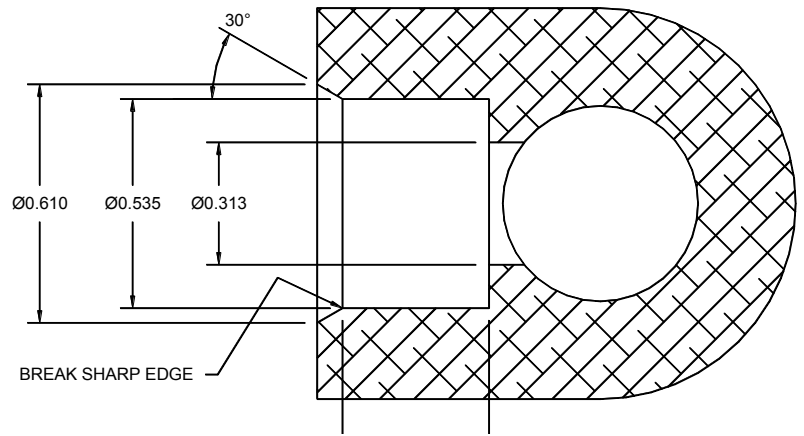

Figure 8

14.0 WIRING

The following overviews how to properly install the wiring harnesses for this system.

14.1 Important Wiring –Do’s and Don’ts”

An EFI system depends heavily on being supplied a clean and constant voltage source. The grounds of an electrical system are just as important as the power side.

HP ECU’s both contain multiple processing devices that require clean power and ground sources. The wiring harnesses for them must be installed in such a manner that they are separated from “dirty” power and ground sources.

DO’S

- Install the main power and ground directly to the battery.
- Keep sensor wiring away from high voltage or “noisy/dirty” components and wiring, especially secondary ignition wiring, ignition boxes and associated wiring.
- Use shielded/grounded cable that is supplied for wiring crankshaft and camshaft signals.
- Properly solder and heat shrink any wire connections.
- It is critical that the engine has a proper ground connection to the battery and chassis.

DON’TS

- NEVER run high voltage or “noisy/dirty” wires in parallel (bundle/loom together) with any EFI sensor wiring. If wires need to cross, try to do so at an angle.
- Do not install Crank and Cam signal wiring close to spark plug and coil wires.
- Do not run non-shielded/grounded wire for crankshaft and camshaft signals, especially magnetic pickups.
- Do not run the USB Communications cable near or with any noisy wires.
- Do not exceed the current limits provided for the various outputs. If current levels exceed these, use the appropriate relay or solenoid drivers.
- Do not use improper crimping tools.
- Don’t use things like “t-taps”, etc. Use solder and heat shrink.
- It is never recommended to splice/share signal wires (such as TPS, etc) between different electronic control units.
- Don’t wire items that require “clean” ground or power to the same points.

15.0 ECU CONNECTORS AND PINOUT

Battery Power Connection – The HP ECU has a main battery power and ground connector on the right side of the ECU. The bottom position, Terminal “A” is the ground. The upper position, Terminal “B” is the positive terminal. Always use the fused power cable with the proper connectors supplied by Holley only.

USB Communications Connector – HP ECU’s use a standard USB cable for Laptop communications. Looking at the front, the connector is at the far left side. This connection is a common “mini USB” connector, typically used for digital cameras and other devices. Holley offers a USB cable with a sealed connector, PN 558-409 for applications where the USB cable will be plugged in, and the ECU is mounted in a dirty environment.

HP ECU – The HP ECU has **two** main connectors:

- **P1A** - The first connector next to the USB connector is the “P1A” connector (34 pin). This connector is primarily an “Input” connector. It contains all the sensor inputs and wide band oxygen sensor control.
- **P1B** - The second connector is the “P1B” connector (26 pin). This connector is the “output” connector. It has 8 injector outputs, 8 DIS ignition outputs, 4 IAC outputs, and 4 user programmable outputs.

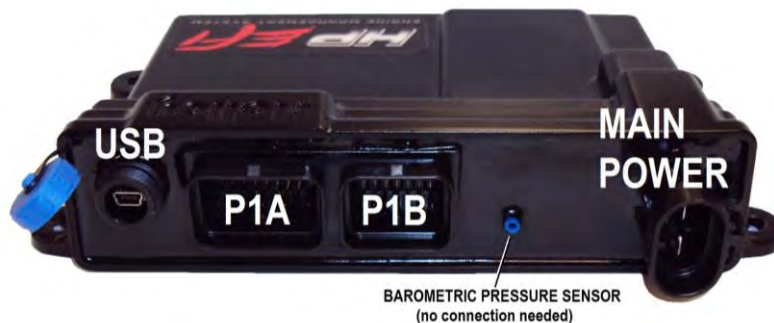

Figure 9

15.1 Pinout

The following is a pinout of the HP ECU connectors.

The P1A and P1B connectors and pinout are identical for the HP and Dominator ECU's.

P1A **Connector**

Pin	Function
A1	Coil - Input
A2	Fuel Pump Out (+12v) (10A Max)
A3	Input #2 (F52THG)
A4	Input #4 (F5G)
A5	TPS Input
A6	Points Trigger Output
A7	WB1 COMPR2
A8	WB1 Shield
A9	WB HTR -
A10	Switched +12v Input
A11	Manifold Air Temp Input
A12	Input #1 (F52THG)
A13	Input #3 (F5G)
A14	Cam/Crank Ground
A15	Gauge Digital Output
A16	WB1 COMPR1
A17	WB1 VS-/IP+
A18	Sensor Ground
A19	Engine Coolant Temp Input
A20	Oil Pressure Input
A21	Knock #2 Input
A22	Cam Sync Input / Ignition Bypass Output
A23	Map Sensor Input
A24	CAN Lo
A25	WB1 VS+
A26	Sensor +5v
A27	NOT USED
A28	EST/Spout Output
A29	Knock #1 Input
A30	Crank Speed Input
A31	Fuel Pressure Input
A32	CAN Hi
A33	WB1 IP+
A34	WB HTR +

P1B Connector

Pin	Function
B1	IAC A Lo
B2	IAC A Hi
B3	Output #4 (G P-)
B4	Injector F Output
B5	Injector G Output
B6	Injector H Output
B7	Injector E Output
B8	IAC B Lo
B9	IAC B Hi
B10	Output #3 (G P-)
B11	Output #2 (H P+)
B12	Output #1 (H P+)
B13	Injector D Output
B14	EST Ground Output
B15	EST 2 Output (Cylinder #2)
B16	EST 4 Output (Cylinder #4)
B17	EST 6 Output (Cylinder #6)
B18	EST 8 Output (Cylinder #8)
B19	Injector A Output
B20	EST 12V Output
B21	EST 1 Output (Cylinder #1)
B22	EST 3 Output (Cylinder #3)
B23	EST 5 Output (Cylinder #5)
B24	EST 7 Output (Cylinder #7)
B25	Injector C Output
B26	Injector B Output

16.0 PRIMARY SENSORS CONNECTION

The following reviews all the connections that must be performed on the “Main Harness”. The Main Harness is the primary harness that supports all the primary engine sensors, fuel and ignition for 8 cylinder engines, the #1 wideband oxygen sensor, and the four programmable input and output channels. There are two connectors for this harness designated as “P1A” (pin designations below that start with an A) and “P1B” (pin designations below that start with a B).

The following descriptions indicate the name of the item and the name as labeled on the harness (each connector has a label) is shown in parenthesis.

16.1 Throttle Position Sensor (TPS)

Connect to the TPS which is located on the throttle body.

16.2 Manifold Air Pressure Sensor (MAP)

A 1 Bar MAP sensor is provided with all Holley EFI systems. Connect to the MAP sensor.

16.3 Coolant Temperature Sensor (CTS)

Connect to the Coolant Temperature sensor which should have been installed in an engine coolant passage.

16.4 Manifold Air Temperature Sensor (MAT)

Connect to the Air Temperature Sensor. Multiport systems will have this installed in the intake manifold and TBI systems will have it installed in the throttle body air inlet.

16.5 Knock Sensor (Knock)

Holley EFI systems work with either a one wire or two wire knock sensor. Application specific harnesses will have the correct knock sensor connections installed on the harness. A Universal harness comes with a 3 pin metripak connector. If a knock sensor is added, it should be connected into this connector

16.6 Wide Band Oxygen Sensor (WB02)

Holley EFI systems can work with either a Bosch (PN 554-101) or NTK (PN 554-100) wide band oxygen sensor. These sensors must be purchased from Holley as they are calibrated specifically for use with Holley EFI systems. HP EFI systems are sold with the Bosch sensor. Make sure you have the proper sensor selected in the Engine Parameters area or sensor damage may occur. Connect the “WB02” connector to the WB02 sensor which should be installed in the exhaust system.

16.7 Fuel Pressure (Fuel)

A fuel pressure transducer connector is pre-installed in the main harness. The system is plug-and-play configured for a Holley 100 PSI pressure transducer (can be purchased under PN 554-102). A different 0-5V transducer can be used, but the calibration must be set up as a custom sensor in the software. If these are not connected to a pressure transducer, the Fuel and Oil Pressure will read “LOW Err” in the data monitor. This will not cause any issues.

NOTE: Connect to the transducer (if installed).

16.8 Oil Pressure (Oil)

An oil pressure transducer connector is pre-installed in the main harness. The system is plug-and-play configured for a Holley 100 PSI pressure transducer (can be purchased under PN 554-102). A different 0-5V transducer can be used, but the calibration must be set up as a custom sensor in the software. If these are not connected to a pressure transducer, the Fuel and Oil Pressure will read “LOW Err” in the data monitor. This will not cause any issues.

NOTE: Connect to the transducer (if installed).

16.9 CANbus (CAN)

All harnesses have a CANbus communications connector. This is used to communicate with CANbus devices such as the Avenger Handheld tuning module or the 5.7” Touch Screen LCD. If these devices or any other CANbus device is not being used, there is no need to do anything with this connector.

A24 CAN Lo (Pin B)

A32 CAN Hi (Pin A)

17.0 PRIMARY OUTPUTS

17.1 Idle Air Control (IAC)

Connect to the idle air control motor which is installed in the throttle body.

17.2 Fuel Injector Outputs (Injectors)

All terminated harnesses have a fuel injector connector. Various fuel injector harnesses plug into this connector. It is essential these harnesses are used so that injector firing sequence is maintained.

Note that for engines with different firing orders, you do NOT change these pins. The engine's firing order is input in the software itself. V8 harnesses offered by Holley are labeled for GM, Ford, and Chrysler engines.

Each injector harness has the engine cylinder number labeled on each injector connector. Connect each injector on the appropriate cylinder.

17.3 Ignition Adapter (Ignition)

The Ignition Adapter connector contains all the wires needed to connect to adapter harnesses offered by Holley for various ignition systems and crank and cam sensor. The only ignition related wiring that is NOT contained on this connector is individual coil driver outputs for DIS applications.

The adapter is pinned as follows:

A30 – Crank signal Input - Both digital and inductive (proper type must be selected in the software) (Pin A)

A22 – Cam signal Input / Ignition Bypass Output – Both digital and inductive (proper type must be selected in the software)

NOTE: If using a computer-controlled GM HEI Distributor, this pin will serve as the ignition bypass output. (Pin B)

A14 – IPU Ground (Pin C)

Chassis Ground – (Pin D)

A10 – Switched +12v (Pin E)

A27 – NOT USED (Pin F)

A14 – IPU Ground (Pin G)

A28 – EST/Spout Output (Pin H)

A14 – Shield Ground (Pin J)

A14 – Shield Ground (Pin K)

NOTE: The crank and cam input wiring in both the main harness and adapter harnesses use a shielded/grounded cable. The shield is grounded at the ECU end. You do not ground both end of shielded/grounded cable. It is always recommended to use shield/grounded cable to protect the integrity of the crank or cam sensor input signals. This is especially important when using a magnetic pickup. A hall effect sensor is much less susceptible to noise interference and is always the recommended sensor type to use.

Holley offers the following ignition adapter harnesses.

- **558-303 – Magnetic Pickup Harness** – Intended for magnetic pickups. Either crank trigger or distributor mounted - Does not contain cam sync wiring.
- **558-304 – HEI** – Connects to a small cap GM HEI computer controlled distributor
- **558-305 – Ford TFI** – Connects to a Ford TFI Distributor.
- **558-306 – Universal Unterminated Ignition Harness** – Contains ignition adapter connector and all wiring to connect to any crank and cam sensors (pins A-K). Also, contains shielded/grounded cable for crank and cam sensor inputs. The user must supply terminals and connectors to plug into their chosen sensors.

NOTE: See section 20.0 for applications and diagrams on wiring most ignition systems.

18.0 LOOSE WIRES

The following loose wires in the main wiring harness should be connected as follows on all systems:

12V Switched – Color = Red/White – Should be connected to a clean +12 volt power source. Power source should only be active when the ignition is on. Make sure source has power when engine is cranking as well. Not all sources apply power when the ignition switch is in “cranking” position.

12V Battery – Color = Red – Should be connected directly to the battery. There is a fuse holder attached that should contain a 20A rated fuse. This powers the fuel pump and fuel injectors.

12V Fuel Pump – Color = Green - Used to directly power a fuel pump (+12 volt). Fully terminated harnesses utilize a relay to supply this power. 14 gauge wire is used. Due to this, it is not recommended for pumps that draw over 10-12 Amps to use this wire. For high current pumps, use this wire to trigger a separate relay and use larger gauge wire to feed the pump - 10 gauge is recommended.

Points Output – Color = White – Used to trigger a CD ignition box. See the ignition wiring section for detailed wiring.

Ignition/DIS Chassis Ground – Color = Black – Connect to a ground point that has excellent connectivity with both the engine and the battery.

Coil – ” – Color = Yellow – Used for an RPM input signal when not controlling timing and NOT running a Capacitive Discharge (MSD) ignition system. See the ignition wiring section 8.0 for detailed wiring.

WARNING! Connecting this wire to the coil of a CD ignition will damage the ECU.

19.0 MAIN POWER HARNESS

Holley HP and Dominator ECU's use the same main power cable. These wires should be run **directly** to the battery. 10 gauge wire is used. The harness comes with a 40 Amp fuse pre-installed. Do not substitute smaller gauge wires.

20.0 IGNITION SYSTEM WIRING

Both the HP and Dominator Systems support a wide variety of ignition systems. The following schematics show how to wire the most typical systems.

20.1 Small Cap Computer Controlled GM HEI

To connect to a small cap computer controlled GM HEI, ignition adapter harness PN 558-304 is required. The following diagrams overview how to wire with and without a CD ignition box.

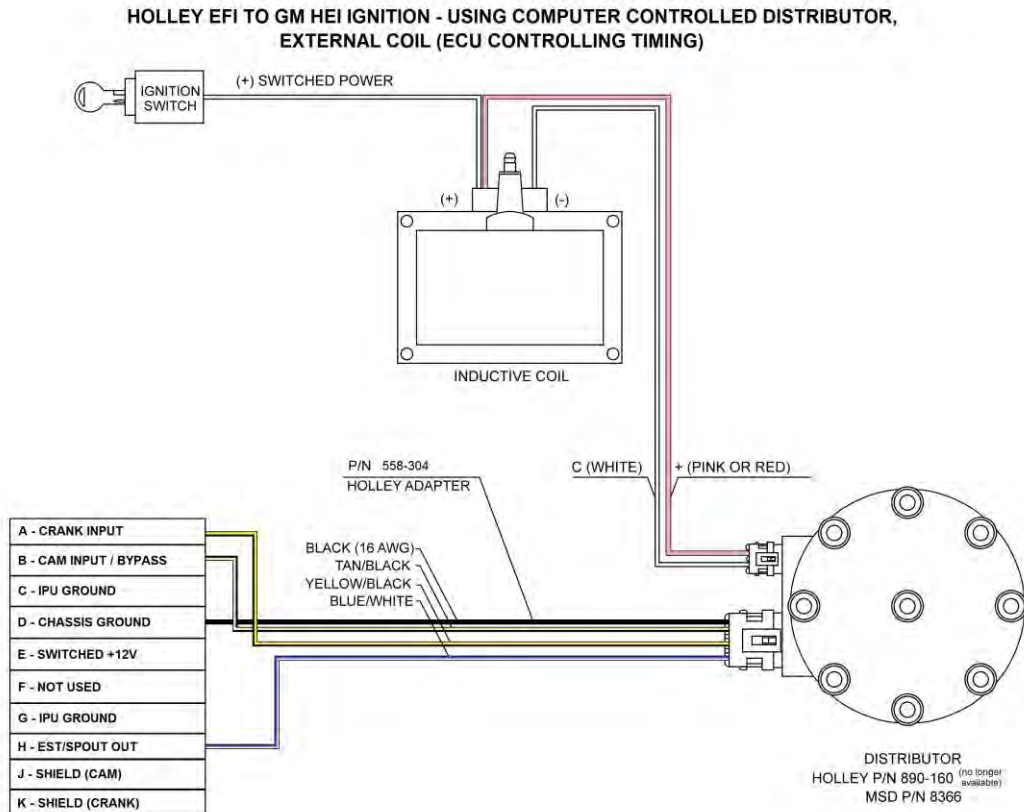

Figure 10

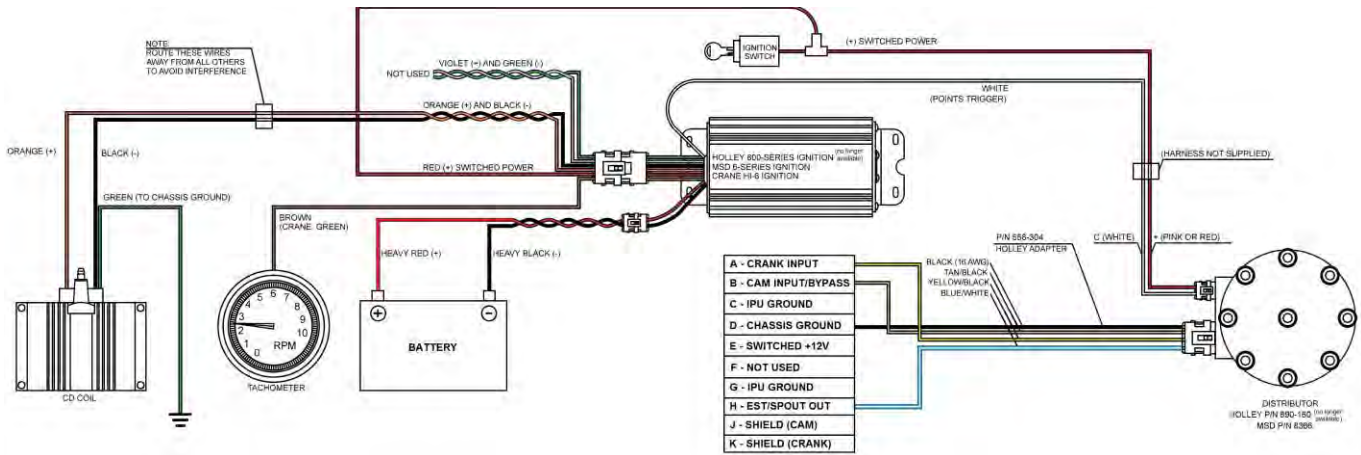

Figure 11

20.2 NON- ECU Controlled Timing Applications (ex. GM Non-ECU Controlled Large Cap HEI)

To connect to a distributor that has mechanical advance and is not controlled by the ECU (ex. GM large cap HEI non-computer controlled distributor), refer to the following diagrams.

- If **NOT** using a CD ignition box, connect the loose YELLOW (NOT yellow/black wire) in the harness to the negative side of the ignition coil.
- If using a CD ignition box, connect the purple crank input wire located in the ignition adapter harness to the “tach out” in the ignition box. This wire is located in Pin A of the 10 pin ignition adapter in the EFI harness (Do **NOT** use the purple wire in pin B – this is for the camshaft sensor input). The following shows three options in order of preference:
 - 1) Some kits come with a 10 pin ignition adapter harness with a single YELLOW/BLACK wire that directly connects to the ignition adapter on the main harness. If you have this adapter, use it to connect the YELLOW/BLACK wire into the tach output of the CD ignition box.
 - 2) If your kit contains an HEI distributor ignition adapter harness (4 wires), you can cut and splice into the YELLOW/BLACK wire in it. This saves you from having to modify the main harness.
 - 3) If you have no ignition adapter harness, you can splice into the purple wire in the main harness.

If splicing is done, make 100% certain that this is a very solid connection. Solder and heat shrink is highly recommended. This supplies the engine speed signal to the ECU and if the connection is not solid, the engine will not run properly.

**HOLLEY EFI TO GM HEI - USING MECHANICAL AND VACUUM ADVANCE
4-PIN MODULE DISTRIBUTOR (ECU "NOT" CONTROLLING IGNITION TIMING)**

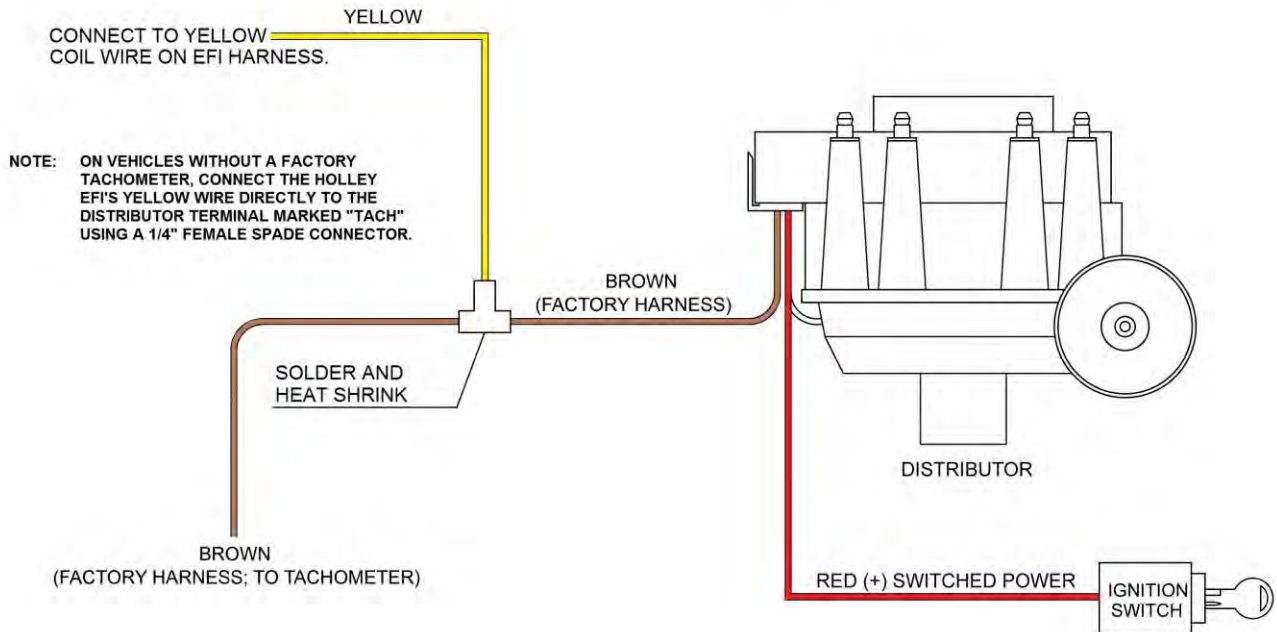

Figure 12

**HOLLEY EFI TO AFTERMARKET IGNITION - USING MAGNETIC PICK-UP DISTRIBUTOR
(ECU "NOT" CONTROLLING IGNITION TIMING)**

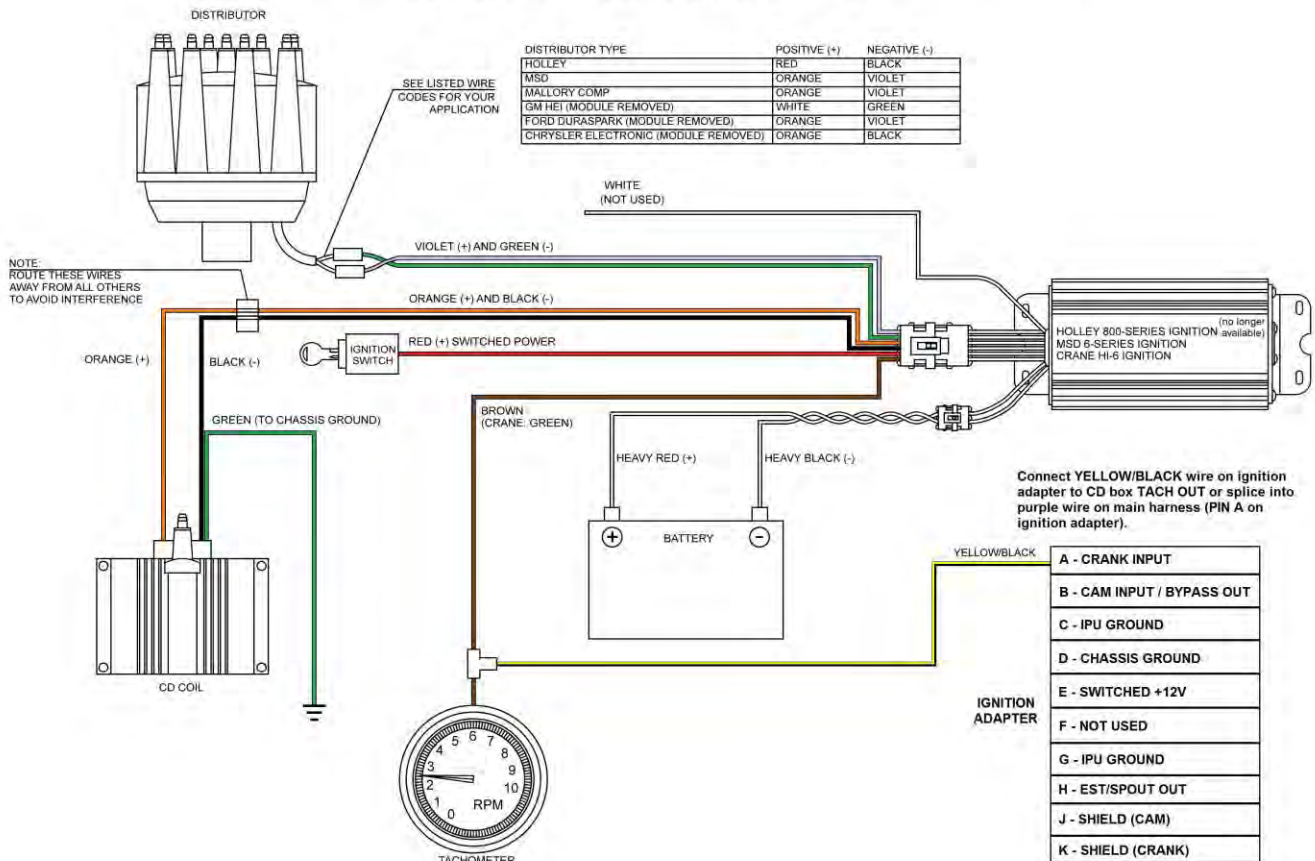

Figure 13

20.3 Magnetic Crank Pickup

The follow diagrams are for running a magnetic pickup, either a crank trigger or a distributor. To run just a magnetic pickup crank input and no camshaft input, PN 558-303 should be purchased. If a cam sync input will be used as well, it is recommended to use PN 558-306 which will contain wiring for both the crank and cam sensor inputs. It is critical that properly installed shielded and grounded cable is used when using a magnetic pickup, or it is likely that EMI will disturb the crankshaft signal. Both PN 558-303 and 558-306 come with the proper cabling. It must be installed properly as well. Make sure that the shield is properly grounded which requires it being grounded at the ECU with that ground maintained through the ignition adapter connection.

Note: The user must supply the proper terminals/connectors for the crank and cam sensors they are using.

HOLLEY EFI TO AFTERMARKET IGNITION - USING MAGNETIC PICK-UP CRANK TRIGGER (ECU CONTROLLING IGNITION TIMING)

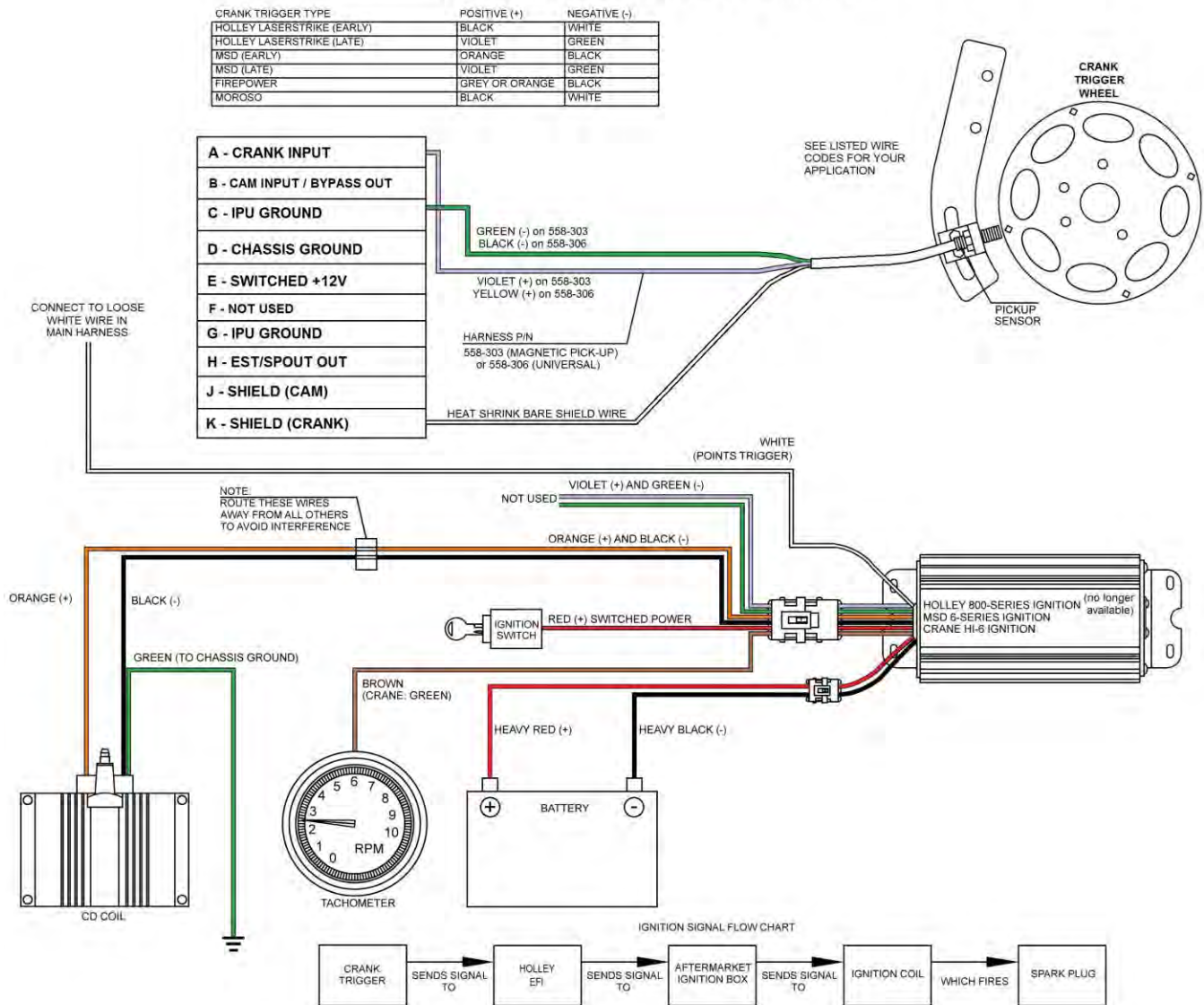

Figure 14

20.4 Magnetic Cam Pickup

The following diagram is to wire a magnetic cam sync signal. It utilizes the shielded/grounded cabling found in PN 558-306. It is critical that properly installed shielded and grounded cable is used when using a magnetic pickup, or it is likely that EMI will disturb the camshaft signal.

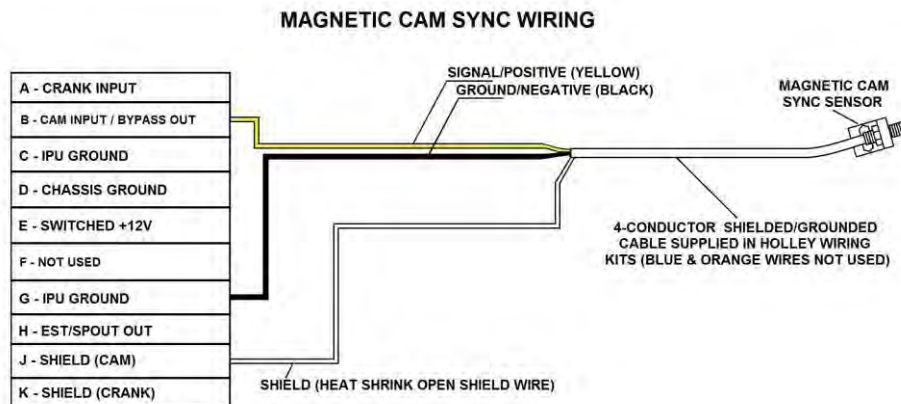

Figure 15

20.5 Hall Effect Crank Pickup

The follow diagrams are for running a hall effect pickup, either a crank trigger or a distributor. It is recommended to use PN 558-306 which will contain wiring for both the crank and cam sensor inputs. It is important that properly installed shielded and grounded cable is used when using a hall effect input. PN 558-306 comes with the proper cabling. It must be installed properly as well. Make sure that the shield is properly grounded which requires it being grounded at the ECU with that ground maintained through the ignition adapter connection.

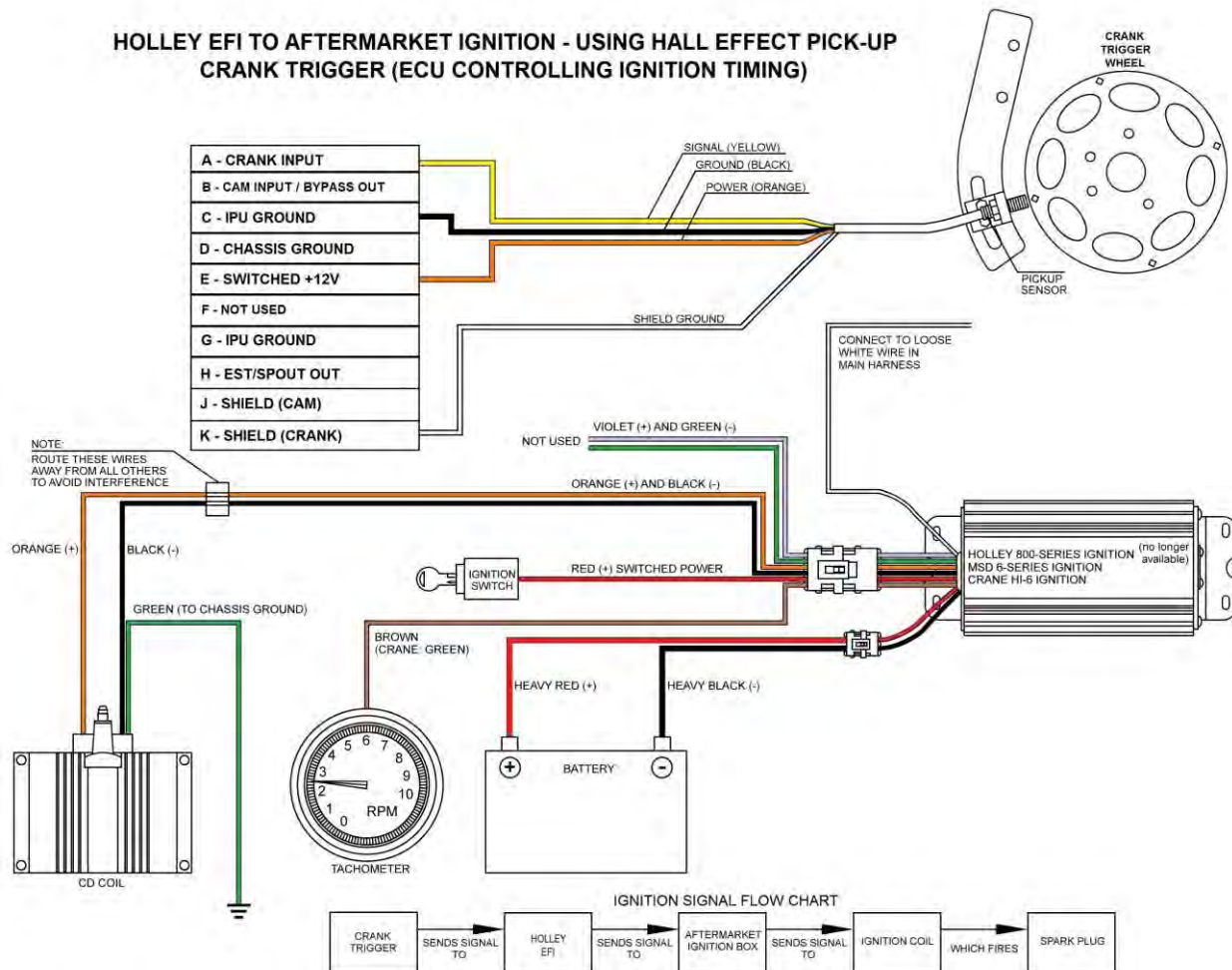

Figure 16

20.6 Hall Effect Cam Pickup

The following diagram is to wire a hall effect cam sync signal. It utilizes the shielded/grounded cabling found in PN 558-306. It is desirable to use a properly installed shielded and grounded cable so that EMI will not disturb the camshaft signal.

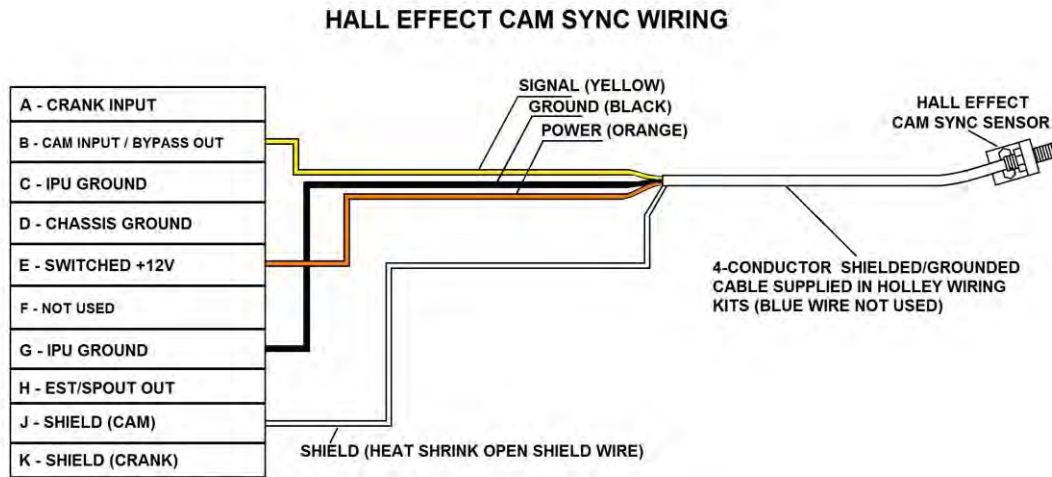

Figure 17

21.0 PROGRAMMABLE INPUTS AND OUTPUTS

Programmable input and outputs are intended to be any input or output that is created by the user when a Global Folder is configured. Once configured, they must be assigned to a specific pin location on the Pin Map, and then physically wired per the assigned location.

The HP ECU has an "Input/Output" connect on the main harness. This is an 8 pin metripak connector. Programmable inputs and outputs can be connected into this connector. PN 558-400 is a harness that plugs into this connector. If you do not want to purchase this harness, use alternative methods to connect to these 8 wires.

This connector is as follows. The functions are described below.

<u>Input/Output Connector Pin</u>	<u>ECU Pin</u>	<u>Wire Color</u>	<u>Function</u>
A	P1-A12	White/Blue	F 5 2 T H G
B	P1-A3	White/Red	F 5 2 T H G
C	P1-A13	White/Black	F 5 G
D	P1-A4	White/Green	F 5 G
E	P1-B12	Grey/Yellow	P+ H
F	P1-B11	Grey/Red	P+ H
G	P1-B10	Grey/Black	P- G
H	P1-B3	Grey/Green	P- G

21.1 Inputs

There are **six** types of inputs that can be configured. The following lists them and reviews wiring recommendations. The designation on the Pin Map (Inputs) is given first, then a description.

1. **H** – Switched 12v or “High Side” input – This input will be triggered when system voltage is applied. Minimum triggering voltage is 4.5v. Do not exceed 24v.

Wiring: Connect up to any voltage source that is desired to trigger this input.

2. **G** – Switched Ground or “Low Side” input – This input will be triggered when a ground is applied.

Wiring: Connect up to any ground source that is desired to trigger this input.

3. **S** – 0-5 volt sensor input – Any 0-5 volt sensor input such as a TPS, MAP sensor, pressure transducer, and many others.

Wiring: Wire the signal wire from the 0-5v sensor used into the appropriate pin. Any 0-5v sensor requires a +5v reference voltage and a sensor ground. On an HP, the user must tie into the existing +5v reference and Sensor Ground lines (which go to any of the 5v sensor such as MAP, TPS, etc). These wires are as follows:

<u>Connector</u>	<u>Sensor +5v Reference Voltage Pin</u>	<u>Sensor Ground Pin</u>
P1A	A26 (Orange)	A18 (Black White)

It is acceptable to have multiple sensors share the same +5v and ground reference lines. Be sure to solder, heat shrink, etc wires properly as poor connections will cause for inaccurate or faulty sensor readings.

Do not use +5v reference or ground sources from other controllers or power supplies to support the sensor, or sensor accuracy may be compromised.

4. **V** – 0-20 volt sensor input – Any 0-20 volt sensor input

Wiring: Connect to desired voltage input.

5. **T** – Thermistor temperature input – Most coolant and air temperature sensors are a 2 wire “thermistor” design.

Wiring: Connect to one side of the thermistor device. Connect the other side of the thermistor device to a “Sensor Ground” input pin to the ECU (same pins for a 0-5v sensor). These pins are as follows:

<u>Connector</u>	<u>Sensor Ground Pin</u>
P1A	A18

6. **F** – Frequency or a Digital Speed Input – Designed for a digital voltage input from a speed/rotation sensor. A hall effect sensor is the common sensor used. Voltage range can be 4.5 to 24 volts.

Wiring: A hall effect sensor has 3 wires: Power, Ground, and Signal. Most sensors can be supplied with battery voltage (12v), a few require a 5 volt reference. Check with the specifications of your specific sensor. Although not usually needed with a hall effect sensor, it is always advised to use a shielded/grounded cable to wire them (all three wires can be shielded). The following is advised when wiring a hall effect sensor.

Signal – Run the sensor signal wire into the Pin Mapped channel

Power – Either supply with clean switched power, or if it is not used for another purpose, you can power from Pin P1B-B20 which is a clean 12v power source. If the sensor requires 5 volts, use a +5v reference line.

Ground – It is best to connect to an IPU (Inductive/Magnetic Pickup) or Sensor Ground. The following pins are IPU grounds:

<u>Connector</u>	<u>Sensor Ground Pin</u>
P1A	A14

Shield Wire – If using shielded/grounded cable, connect the shield ground wire to the ECU only - best to connect it to an IPU ground.

21.2 Outputs

All PWM (Pulse Width Modulated) and switched outputs are rated at a maximum of 2A. If a device will draw more than 2A, some type of relay must be used. If the output is PWM, do not use a “switching” relay, but rather a solid state type relay designed to be pulse width modulated.

There are four types of outputs that can be configured. The following lists them and reviews wiring recommendations. The designation on the Pin Map (Outputs) is given first, then a description.

1. **-H** – Switched 12v or “High Side” output – will output system voltage level.

Wiring: Connect the pin to the device to be triggered.

2. **-G** – Ground or “Low Side” output – will output a ground trigger.

Wiring: Connect the pin to the device to be triggered.

3. **-P+** - 12v Pulse Width Modulated output – Outputs a high side pulse width modulated output to control items such as a progressive nitrous solenoid or a PWM IAC – will output system voltage level.

Wiring: Connect the pin to the device to be triggered. A PWM device has 2 wires, connector the other side of the device to ground.

4. **-P'** – Ground Pulse Width Modulated output – Outputs a low side pulse width modulated output to control items such as a progressive nitrous solenoid or a PWM IAC.

Wiring: Connect the pin to the device to be triggered. A PWM device has 2 wires, connector the other side of the device to a voltage source.



**Holley Performance Products
1801 Russellville Road, Bowling Green, KY
42101**

**Technical Service: 270-781-9741
Fax: 270-781-9772
For online help, please refer to the Tech
Service section of our website:
www.holley.com**

**199R10510 wf
Date: 5-10-11**

271R960A HOLLEY EFI MPFI MAIN HARNESS

(HARNESS ONLY SALES P/N 558-104)

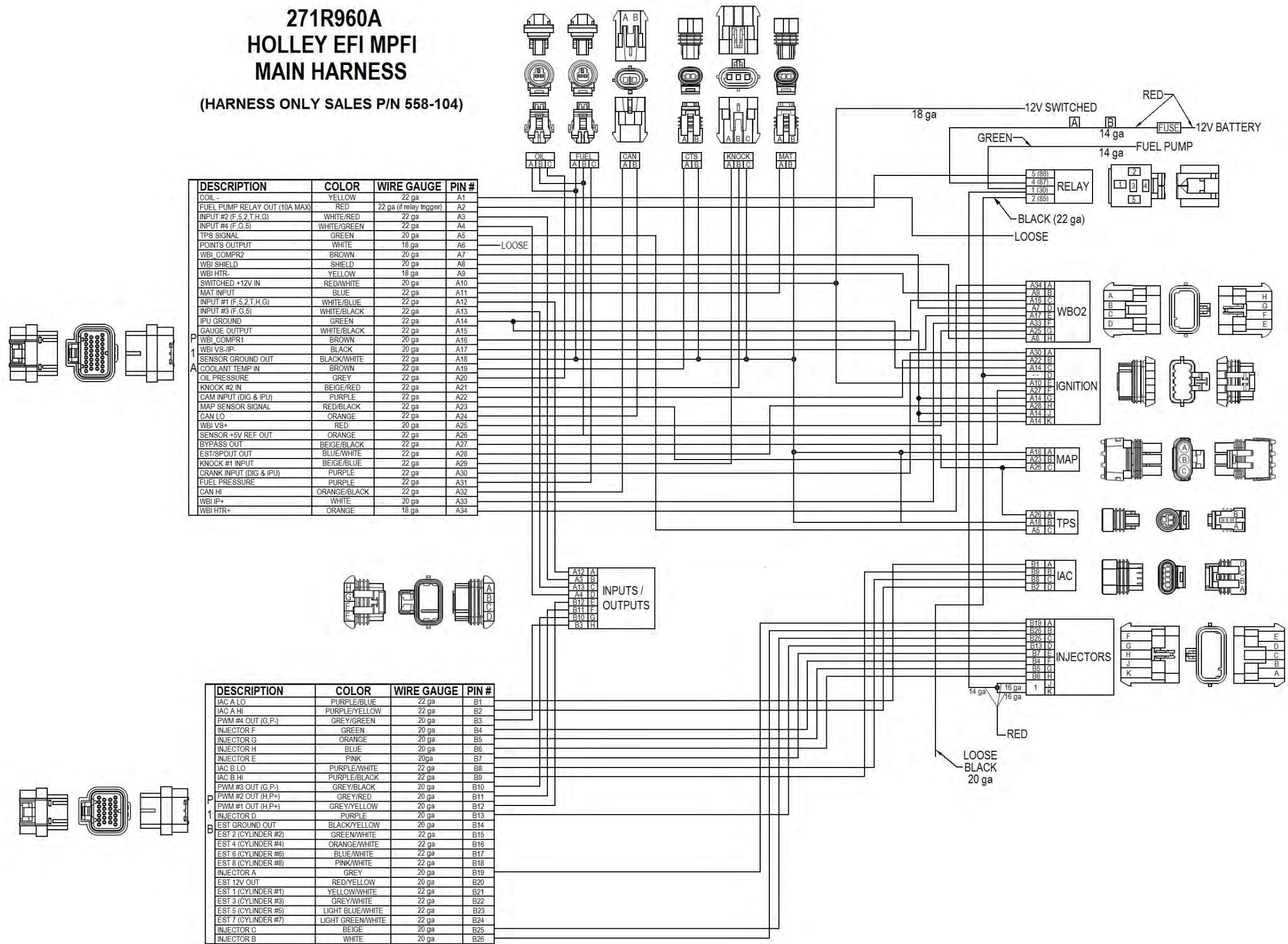

DESCRIPTION	COLOR	WIRE GAUGE	PIN #
COIL	YELLOW	22 ga	A1
FUEL PUMP RELAY OUT (10A MAX)	RED	22 ga (if relay trigger)	A2
INPUT #2 (F, 5.2, T, H, G)	WHITE/RED	22 ga	A3
INPUT #4 (F, G, 5)	WHITE/GREEN	22 ga	A4
TPS SIGNAL	GREEN	20 ga	A5
POINTS OUTPUT	WHITE	18 ga	A6
WBI COMPR2	BROWN	20 ga	A7
WBI SHIELD	SHIELD	20 ga	A8
WBI HTR-	YELLOW	18 ga	A9
SWITCHED +12V IN	RED/WHITE	20 ga	A10
MAT INPUT	BLUE	22 ga	A11
INPUT #1 (F, 5.2, T, H, G)	WHITE/BLUE	22 ga	A12
INPUT #3 (F, G, 5)	WHITE/BLACK	22 ga	A13
IPU GROUND	GREEN	22 ga	A14
GAUGE OUTPUT	WHITE/BLACK	22 ga	A15
WBI COMPR1	BROWN	20 ga	A16
WBI VS-IP-	BLACK	20 ga	A17
SENSOR GROUND OUT	BLACK/WHITE	22 ga	A18
COOLANT TEMP IN	BROWN	22 ga	A19
OIL PRESSURE	GREY	22 ga	A20
KNOCK #2 IN	BEIGE/RED	22 ga	A21
CAM INPUT (DIG & IPU)	PURPLE	22 ga	A22
MAP SENSOR SIGNAL	RED/BLACK	22 ga	A23
CAM LO	ORANGE	22 ga	A24
WBI VS+	RED	20 ga	A25
SENSOR +5V REF OUT	ORANGE	22 ga	A26
BYPASS OUT	BEIGE/BLACK	22 ga	A27
EST/SPOUT OUT	BLUE/WHITE	22 ga	A28
KNOCK #1 INPUT	BEIGE/BLUE	22 ga	A29
CRANK INPUT (DIG & IPU)	PURPLE	22 ga	A30
FUEL PRESSURE	PURPLE	22 ga	A31
CAN HI	ORANGE/BLACK	22 ga	A32
WBI IP+	WHITE	20 ga	A33
WBI HTR+	ORANGE	18 ga	A34

DESCRIPTION	COLOR	WIRE GAUGE	PIN #
IAC A LO	PURPLE/BLUE	22 ga	B1
IAC A HI	PURPLE/YELLOW	22 ga	B2
PWM #4 OUT (G, P-)	GREY/GREEN	20 ga	B3
INJECTOR F	GREEN	20 ga	B4
INJECTOR G	ORANGE	20 ga	B5
INJECTOR H	BLUE	20 ga	B6
INJECTOR E	PINK	20 ga	B7
IAC B LO	PURPLE/WHITE	22 ga	B8
IAC B HI	PURPLE/BLACK	22 ga	B9
PWM #3 OUT (G, P-)	GREY/BLACK	20 ga	B10
PWM #2 OUT (H, P+)	GREY/RED	20 ga	B11
PWM #1 OUT (H, P+)	GREY/YELLOW	20 ga	B12
INJECTOR D	PURPLE	20 ga	B13
EST GROUND OUT	BLACK/YELLOW	20 ga	B14
EST 2 (CYLINDER #2)	GREEN/WHITE	22 ga	B15
EST 4 (CYLINDER #4)	ORANGE/WHITE	22 ga	B16
EST 6 (CYLINDER #6)	BLUE/WHITE	22 ga	B17
EST 8 (CYLINDER #8)	PINK/WHITE	22 ga	B18
INJECTOR A	GREY	20 ga	B19
EST 12V OUT	RED/YELLOW	20 ga	B20
EST 1 (CYLINDER #1)	YELLOW/WHITE	22 ga	B21
EST 3 (CYLINDER #3)	GREY/WHITE	22 ga	B22
EST 5 (CYLINDER #5)	LIGHT BLUE/WHITE	22 ga	B23
EST 7 (CYLINDER #7)	LIGHT GREEN/WHITE	22 ga	B24
INJECTOR C	BEIGE	20 ga	B25
INJECTOR B	WHITE	20 ga	B26

271R960A HOLLEY EFI MPFI MAIN HARNESS

(HARNESS ONLY SALES P/N 558-104)

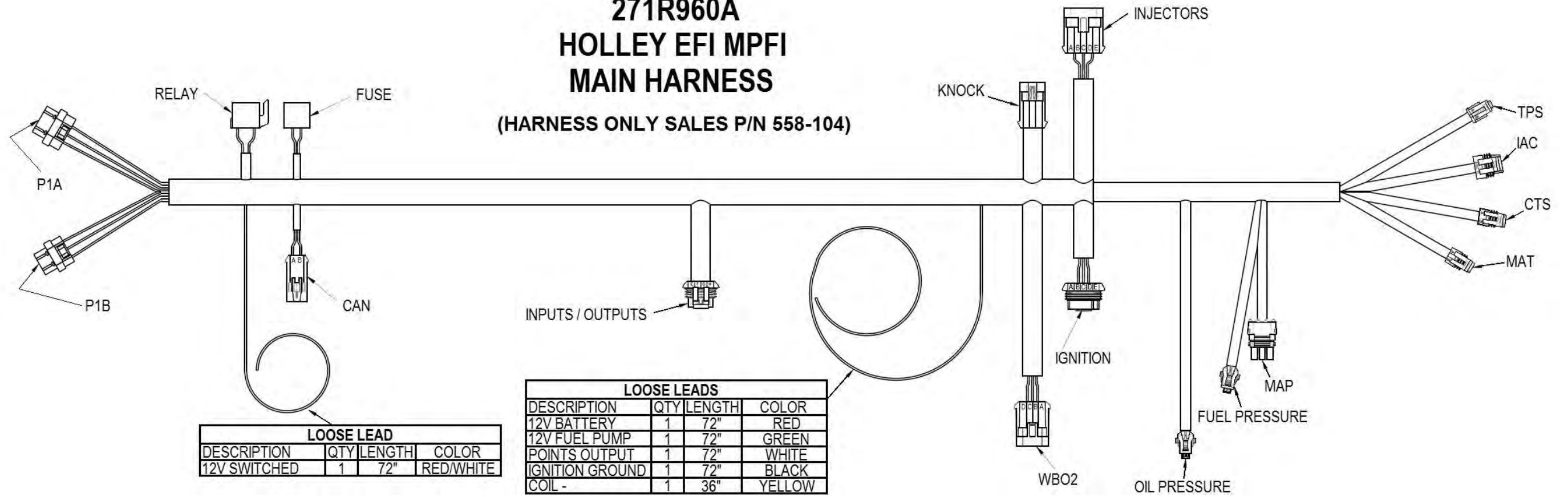

LOOSE LEAD			
DESCRIPTION	QTY	LENGTH	COLOR
12V SWITCHED	1	72"	RED/WHITE

LOOSE LEADS			
DESCRIPTION	QTY	LENGTH	COLOR
12V BATTERY	1	72"	RED
12V FUEL PUMP	1	72"	GREEN
POINTS OUTPUT	1	72"	WHITE
IGNITION GROUND	1	72"	BLACK
COIL -	1	36"	YELLOW