



MARINE

PRO-JECTION[®] 2D

Part Number

700-21

For V-8 Engines

**INSTALLATION, TUNING, AND
TROUBLESHOOTING MANUAL**

NOTE: These instructions must be read and fully understood before beginning installation. If this manual is not fully understood, installation should not be attempted. Failure to follow these instructions, including the pictures may result in subsequent system failure.

TABLE OF CONTENTS:

1.0 INTRODUCTION	3
2.0 WARNINGS, NOTES, AND NOTICES	3
3.0 PARTS IDENTIFICATION	4
4.0 ADDITIONAL ITEMS REQUIRED FOR INSTALLATION	6
5.0 TOOLS REQUIRED FOR INSTALLATION	6
6.0 SYSTEM OVERVIEW	7
7.0 REMOVAL OF EXISTING FUEL SYSTEM	7
8.0 INSTALLATION OF THE MARINE PROJECTION FUEL SYSTEM	8
8.1 Adapter Plate Installation	8
8.1.1 Square Flange Manifolds	8
8.1.2 Universal and Spread Bore Manifolds	9
8.2 Throttle Body Installation	10
8.3 Throttle Connections	10
8.4 Fuel Pump Installation	11
8.5 Fuel Pump and Throttle Body Filter	11
8.6 Return Line Installation	12
8.7 Inlet Fuel Line Installation	13
8.7.1 Installation with Fuel Return Line to Fuel Tank	13
8.7.2 Installation with Fuel Return Line to Electric Pump	13
8.8 Coolant Temperature Sensor	14
9.0 CLOSED LOOP INSTALLATION AND CONNECTION (OPTIONAL):	14
10.0 MOUNTING THE ELECTRONIC CONTROL UNIT (ECU):	15
11.0 ENGINE WIRING HARNESS	16
12.0 ELECTRICAL CONNECTIONS	17
13.0 FINAL CONNECTIONS	18
14.0 OPERATIONAL OVERVIEW OF THE DIGITAL ECU	18
14.1 Main	19
14.2 Idle	19
14.3 High RPM	20
14.4 ACCEL Pump	20
14.5 Choke	20
15.0 BEFORE STARTING THE ENGINE	20
16.0 SETTING THE MECHANICAL IDLE	20
17.0 SETTING THE THROTTLE POSITION SENSOR (TPS)	21
18.0 TUNING THE DIGITAL ECU FOR PERFORMANCE	22
18.1 Tuning the Main	22
18.2 Tuning the Idle	22
18.3 Tuning the ACCEL	23
18.4 Tuning the High RPM	23
18.5 Tuning the Choke	23
19.0 MAINTENANCE AND STORAGE	23
20.0 TROUBLESHOOTING AND COMPONENT TESTING	24
20.1 Adjusting the Fuel Pressure	26
20.2 Testing the Coolant Temperature Sensor	26
20.3 Testing the Throttle Position Sensor	27
20.4 Testing the Oxygen Sensor (if equipped)	28

1.0 INTRODUCTION

Holley Performance Products has written this manual for the installation of the marine **PRO-JECTION 2D** fuel injection system. This manual contains all the information needed to install this system. Please read all the **WARNINGS, NOTES, and TIPS**, as they contain valuable information that can save you time and money. It is our intent to provide the best possible products for our customer; products that perform properly and satisfy your expectations. Should you need information or parts assistance, please contact our technical service department at 1-270-781-9741, Monday through Friday, 7 a.m. to 5 p.m. Central Time. By using this number, you may obtain any information and/or parts assistance that you may require. Please have the part number of the product you purchased when you call.

WARNING! The **PRO-JECTION 2D** system consists of a number of sophisticated components. Failure of any one component does not constitute, nor does it justify, warranty of the complete system. Individual service items are available for replacement of components. If assistance is required or if you need further warranty clarification, you can call Holley Technical Service at the number shown above.

WARNING! To preserve warranty, these instructions must be read and followed thoroughly and completely before and during installation. It is important that you become familiar with the parts and the installation of the **PRO-JECTION** system before you begin. Failure to read and understand these instructions could result in damage to **PRO-JECTION** components that are not covered by the warranty and could result in serious personal injury and property damage.

WARNING! For closed loop systems using an oxygen sensor, use only unleaded fuels with this product. Use of leaded fuels will destroy the oxygen sensor and will result in incorrect exhaust gas oxygen readings and improper fuel delivery. Failure to follow these directions does not constitute the right to a warranty claim.

WARNING! Failure to follow all of the above will result in an improper installation, which may lead to personal injury, including death, and/or property damage. Improper installation and/or use of this or any Holley product will void all warranties.

2.0 WARNINGS, NOTES, AND NOTICES

WARNING! For the safety and protection of you and others, only a trained mechanic having adequate marine fuel system experience must perform the installation, adjustment, and repair. It is particularly important to remember one of the very basic principles of marine safety: fuel vapors are heavier than air and tend to collect in lower places. Any fuel spilled will vaporize and remain in the lowest extremes of the engine compartment of your vessel where an explosive fuel/air mixture may be ignited by any spark or flame resulting in property damage, personal injury and/or death. Extreme caution must be exercised to prevent spillage and thus eliminate the formation of such fuel vapors. In all cases, it necessary to have and properly operate the bilge blower for a length of time sufficient to remove all vapors before starting your vessel's engine.

WARNING! United States Coast Guard (U.S.C.G.) regulations apply to vessel equipment specification and operations. Prior to performing installation, review all pertinent U.S.C.G. rules and regulations.

WARNING! For the safety and protection of persons and property and compliance with all U.S.C.G. and other marine safety requirements and recommendations, the following instructions must be carefully studied and applied.

WARNING! Due to the large distance between the helm and the engine in most boats, it is required that the mechanic have an assistant to operate the helm controls during removal, installation, adjustment, or repair of any marine fuel system component, as well as during the starting procedure.

WARNING! A U.S.C.G. approved fire extinguisher, in proper operating condition, should be nearby at all times during removal, installation, adjustment, or repair of the marine fuel system, and during the starting procedure.

3.0 PARTS IDENTIFICATION

<u>ITEM</u>	<u>DESCRIPTION</u>	<u>QTY</u>	<u>SERVICE PART</u>
1	TBI Assembly 700 CFM Complete	1	500-13
2	Electronic Control Unit (ECU) D Systems	1	N/A
3	Wiring Harness	1	534-34
4	Fuel Pump	1	12-927
5	Fuel Pump Clamp	1	N/A
6	Flame Arrestor	1	720-1
7	Manifold Adapter (square flange)	1	17-6
8	Universal Manifold Adapter	1	17-41
9	Universal Manifold Adapter Gasket	1	508-5
10	Square Flange Manifold Adapter Gasket	1	108-10
11	TBI Flange Gasket	1	508-6
12	Coolant Temperature Sensor	1	534-2
13	Oxygen Sensor (optional)	1	43-106
14	Fuel Pump Block-Off Plate	1	12-813
	Fuel Pump Block-Off Plate Gasket	1	N/A
15	Throttle Extension Bracket	1	N/A
16	Throttle Extension Bracket Screw and Nut	2	N/A
17	Fuel Filter	1	562-1
18	Fuel Filter Clamp	1	N/A
19	Hose Barb Fitting 3/8 inch	2	N/A
20	Hose Barb Fitting 1/4 inch	1	N/A
21	Brass Tee Connector	1	N/A
22	TBI Mounting Stud	3	N/A
23	Flame Arrestor Mounting Stud	1	N/A
24	Universal Manifold Adapter Screw	8	N/A
25	Nylock Hex Nut (5/16-24)	3	N/A
26	Nylock Hex Nut (1/4"-20)	1	N/A
27	Wire Harness Bracket	1	N/A
28	Cable Ties	12	N/A
29	Hose Clamp	8	N/A
30	Insulated 1/4" Female Quick Disconnect	1	N/A
31	Adapter Plate Plug	3	N/A
32	Pipe Plug	1	N/A
	Dielectric Grease (Not Pictured)	1	N/A
	Loctite (Not Pictured)	1	N/A
	1/4" Marine Fuel Hose (Not Pictured)	4'	N/A
	5/16" Marine Fuel Hose (Not Pictured)	4'	N/A
	3/8" Marine Fuel Hose (Not Pictured)	2'	N/A

TBI Service Parts:

Fuel Injector	4	522-43
Throttle Position Sensor (TPS)	1	543-3



Item 1



Item 2



Item 3



Item 4



Item 5



Item 6



Item 7

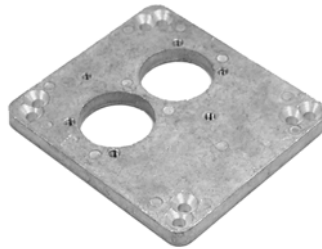

Item 8

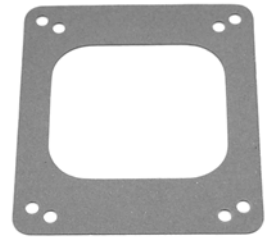

Item 9

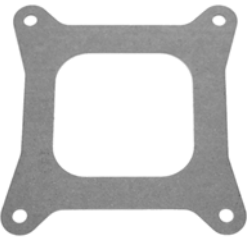

Item 10



Item 11



Item 12



Item 13

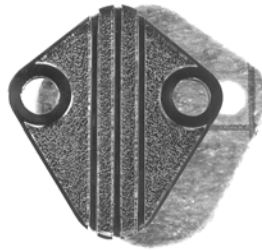

Item 14



Item 15



Item 16



Item 17



Item 18



Item 19



Item 20



Item 21



Item 22



Item 23



Item 24



Item 25



Item 26



Item 27



Item 28



Item 29



Item 30



Item 31



Item 32

4.0 ADDITIONAL ITEMS REQUIRED FOR INSTALLATION

- more 3/8" Marine fuel hose marked U.S.C.G. Type A1 (if needed)
- 5/16" US Coast Guard approved seamless metallic fuel line
- 0-30 psig fuel gauge
- more 5/16" Marine fuel hose marked U.S.C.G. Type A1 (if needed)
- Tee fitting for fuel gauge

In addition to the above list, the boat's engine must be equipped with a four barrel intake manifold, there must be adequate hatch clearance (1" taller than stock) and the boat's engine and electrical system must be in good operating condition.

5.0 TOOLS REQUIRED FOR INSTALLATION

- 1/2" Socket and Wrench
- Medium blade standard screwdriver
- Drill and assorted bit sizes
- Engine tachometer
- 12 volt test light
- Small blade standard screwdriver
- #2 Phillips screwdriver
- Hole saw (2")
- Torque wrench
- 5/32" Allen wrench
- Digital Volt-Ohm meter
- Terminal crimping tool
- Utility knife

An assistant is necessary for some installation and adjustment procedures and should be present for safety reasons. If you don't have a test light, we would suggest that you purchase one for use in this installation.

6.0 SYSTEM OVERVIEW

The projection system actually consists of three systems; the air and fuel delivery, the fuel return system, and the electronic control system. Because the ECU utilizes digital electronics, it is not affected by variations in temperature or humidity.

Although the digital ECU is pre-programmed at the factory, the amount of fuel delivered to the engine under various operating conditions is user-adjustable through the use of five adjustments knobs located on the front panel of the digital ECU. These adjustment knobs are used to tune the system. The Digital ECU has adjustments for Choke, Acceleration, Idle, Main, and High RPM settings. By simply dialing in the appropriate fuel curve, fuel delivery can be accurately matched to the engine's requirements across its entire power band.

The fuel is pumped from the tank to the Pro-Jection throttle body through the fuel filter. At the rear of the throttle body is the fuel pressure regulator, which maintains the fuel pressure at 15 psi (or any pressure you choose between 12 and 22 psi). Excess fuel not injected into the engine is returned to the fuel tank via the fuel return line.

The ECU is factory programmed and controls the amount of fuel delivered to the engine by pulsing each of the two fuel injectors for precisely controlled periods of time. The rate and length of time at which the injectors are pulsed is calculated from various inputs such as engine speed, throttle position, engine coolant temperature, and an optional oxygen sensor. Below is a Projection system layout of all three systems.

WARNING! The Digital Pro-Jection system is NOT recommended for high-speed, high-performance engine applications.

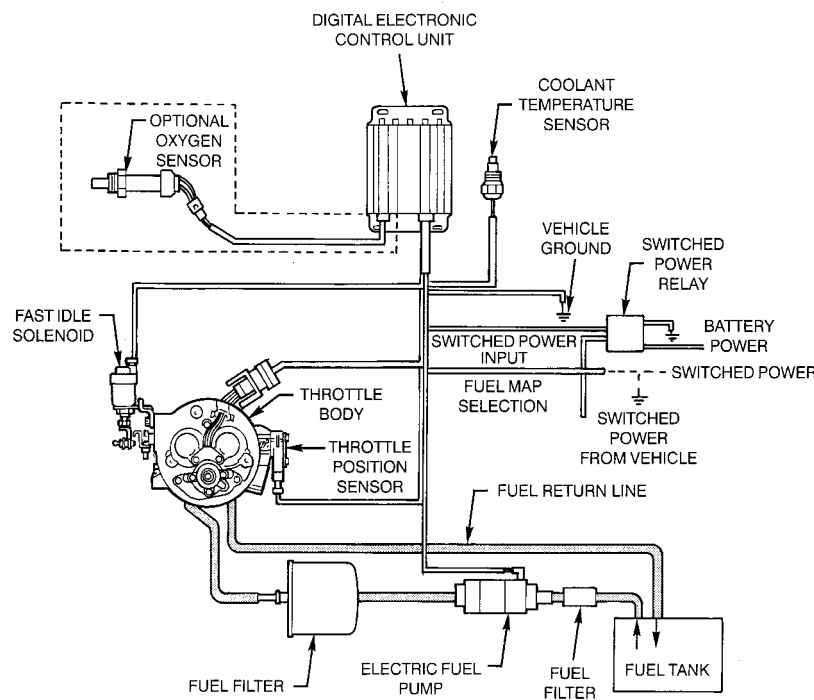

Figure 1

NOTE: Although every possible precaution was taken in the design of the digital ECU to prevent interference from radio sources, the use of solid core spark plug wires may interfere with the operation of the ECU. Holley recommends the use of either suppression or spiral wound spark plug wires, such as Holley Part #'s 50-9800, 50-9801, or 50-9804.

7.0 REMOVAL OF EXISTING FUEL SYSTEM

1. Disconnect the battery and remove the flame arrestor.
2. Before disconnecting any vacuum hoses, it is a good idea to sketch out the vacuum hose routing. Using masking tape and a permanent marker, mark all the vacuum hoses, vacuum sources and ports before removing the old fuel delivery system.
3. Remove and discard the fuel line that connects the fuel delivery system to the fuel pump. This will not be needed in the installation.

4. Disconnect and plug the inlet fuel line that runs from the gas tank to the fuel pump. This will prevent fuel spillage and foreign matter or dirt from entering the fuel line.

DANGER! BEFORE DISCONNECTING OR REMOVING FUEL LINES, ENSURE THE ENGINE IS COLD. DO NOT SMOKE. EXTINGUISH ALL OPEN FLAMES. AN OPEN FLAME, SPARK, OR EXTREME HEAT NEAR GASOLINE CAN RESULT IN A FIRE OR EXPLOSION CAUSING PROPERTY DAMAGE, SERIOUS INJURY, AND/OR DEATH.

5. The fuel delivery system can now be removed. Holley recommends removing the mechanical fuel pump, if so equipped, and blocking-off the fuel pump mount using the provided fuel pump block off plate. The **PRO-JECTION** system kit includes a block-off plate that will fit small and big block Chevrolet and Chrysler engines. If the block-off plate does not fit your engine, a block-off plate may have to be purchased from a local performance parts supplier.
6. If required, replace the intake manifold at this time. Proceed to step seven if this is not required. **A 4-BARREL STOCK OR AFTERMARKET INTAKE MANIFOLD IS REQUIRED FOR THE INSTALLATION OF THE HOLLEY DIGITAL PRO-JECTION.**
7. Place clean shop towels or rags into the manifold opening to prevent dirt or debris from entering the engine. Keep exposed ends of vacuum and fuel lines free from dirt.

WARNING! Failure to cover the intake opening with a clean towel could result in dirt or debris entering the engine. Dirt or debris in the induction system can cause engine damage, which may necessitate a complete engine overhaul.

8. Remove all traces of the old gasket material from the TBI mounting flange. **DO NOT** gouge the intake manifold sealing surface during removal of old gasket material. Failure to remove all traces of old gasket material will result in vacuum leaks that will be difficult to detect later. Sealing flanges must be clean and dry before installation.
9. Remove the shop towels from the intake and vacuum out the intake channel to ensure no dirt or debris is left in the intake system. Place shop towel over the entire intake opening until you are ready to install the new **PRO-JECTION** TBI.

8.0 INSTALLATION OF THE MARINE PRO-JECTION FUEL SYSTEM

8.1 Adapter Plate Installation

Determine which type of mounting flange you have on your intake manifold. A square flange accepts a standard Holley carburetor or universal, and a spread bore flange accepts a Rochester Quadra-Jet carburetor. Make sure the gasket surface on the mounting flange is clean and any old gasket material has been removed. After determining the mounting flange requirements, find the appropriate installation listed below.

8.1.1 Square Flange Manifolds

1. Using Figure 2 as your guide, place the square-holed gasket and then the manifold adapter on the manifold. The square opening of the adapter should be facing downward and the wide opening should be facing upward toward the FRONT of the engine.
2. Check to ensure that the gasket lies flat and adequately covers all surfaces.
3. Put the gasket and then the adapter over the manifold adapter. Position the bores, so they are placed forward toward the primary bores of the manifold.
4. Insert the four 1-3/4" adapter bolts through the outer holes of the adapters and gaskets and into the manifold. Torque the bolts to 15 ft./lbs. in two steps. First, torque each to 8 ft./lbs., and then to 15 ft./lbs. in a criss-cross pattern.

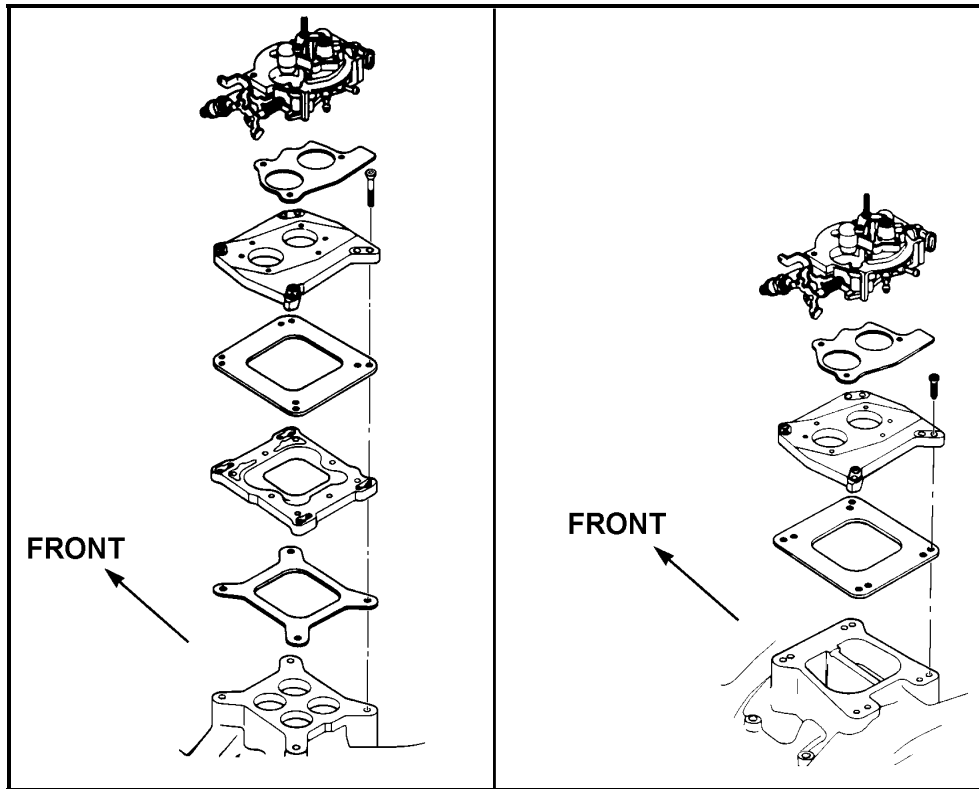

Figure 2

Figure 3

8.1.2 Universal and Spread Bore Manifolds

WARNING! If using an aftermarket manifold on a Chevrolet small block, position the adapter bores so they are forward toward the front of the manifold. On all other applications with any type of manifold, stock or aftermarket, position the adapter bores so they are forward toward the front or primary bores of the manifold. On factory big block Chevrolet manifolds, the throttle body must be mounted forward even though the bores don't line up properly. This must be done to prevent the front cylinders from running lean.

1. Using Figure 3 as your guide, put the gasket and then the adapter on the manifold.

NOTE: On a small block Chevrolet application with stock intake manifold, position the adapter so the bores are over the large secondary bores in the manifold.

2. Check to ensure that the gasket lays flat and adequately covers the sealing surface.

3. Insert the four 1-1/4" adapter bolts through the inner holes of the adapter and gasket and into the manifold. Torque the bolts to 15 ft./lbs. in two steps. First, torque each to 8 ft./lbs. and then to 15 ft./lbs. in a criss-cross pattern.

NOTE: Some applications originally equipped with a Quadra-Jet carburetor may require the use of Holley's throttle cable bracket P/N 717-6.

NOTE: Mercruiser applications will require the throttle cable bracket P/N 717-6 and Holley's linkage adapter P/N 717-7. Install the bracket along with the proper gaskets between the manifold and the adapter plate.

NOTE: Throttle extension bracket must also be used when the TBI is mounted over the secondary bores on stock small block Chevrolet manifolds. Mount this to the 717-6 bracket using the two nuts and bolts that are provided.

WARNING! The universal manifold adapter has six-threaded TBI mounting holes and only three of these will be used to mount the TBI. Plug the remaining holes by applying a couple drops of Loctite to each plug and insert into the unused holes. Use a 5/32 hex wrench and screw each plug in until the sit below the adapter plate surface.

8.2 Throttle Body Installation

NOTE: Remove and discard the special shipping bolt as shown in Figure 4. Apply a couple drops of Loctite to the long end of the flame arrestor stud and insert into the throttle body and tighten securely. After the flame arrestor is installed it is **EXTREMELY IMPORTANT** that the flame arrestor stud does not extend any farther than 1/2 inch past the top cover of the flame arrestor, damage to the engine cover or hatch may result. Trimming may be necessary.

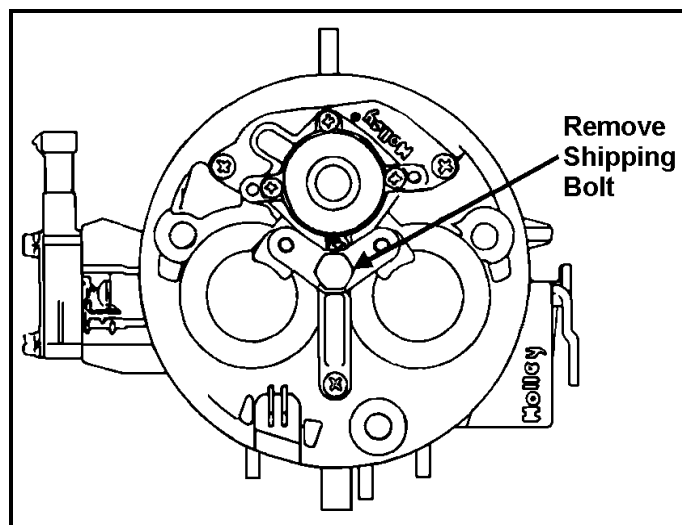

Figure 4

1. Locate the three 5/16" studs and screw the coarse thread ends into the proper TBI adapter mounting holes.
2. Place the gasket and throttle body over the studs and tighten with locking nuts to 15 ft./lbs. in two steps. First, torque each to 8 ft./lbs. and then to 15 ft. /lbs. in a criss-cross pattern.

8.3 Throttle Connections

NOTE: Some applications originally equipped with a Quadra-Jet carburetor may require the use of Holley's throttle cable bracket P/N 717-6.

NOTE: Mercruiser applications will require the throttle cable bracket P/N 717-6 and Holley's linkage adapter P/N 717-7. Install the bracket along with the proper gaskets between the manifold and the adapter plate.

NOTE: Throttle extension bracket must also be used when the TBI is mounted over the secondary bores on stock small block Chevrolet manifolds. Mount this to the 717-6 bracket using the two nuts and bolts that are provided. Or when the old throttle lever arm is significantly longer than the Pro-Jection throttle lever arm. See step 2.

1. Remove any studs or brackets that are on the carburetor throttle lever and transfer them over to the lever of the TBI in the same relative location. Connect the throttle cable to the lever using the original equipment hardware. If Using the Holley 717-6 and/or 717-7 throttle linkage kits. Follow the instructions that come with these kits. In some cases it will require the use of the throttle lever extension brackets. Step two outlines the procedure for using the throttle lever extension bracket.
2. Measure the length of the throttle lever arm on the carburetor removed from the boat. Compare the length of the existing throttle lever arm with the one on the **PRO-JECTION** throttle body. If the two throttle lever arms are similar in length (within 1/2" of each other), the throttle lever arm hole on the **PRO-JECTION** throttle body can be used without the extension bracket. Use the throttle lever arm extension bracket if the old throttle lever arm is significantly longer than the **PRO-JECTION** throttle lever arm. Before installation of the bracket, check the diameter of the throttle cable stud. Some Systems may use a 1/4" stud that will require drilling of the appropriate hole in the extension bracket to a 1/4" diameter. Attach the extension bracket using two fillister head screws. The extension lever length can be adjusted using the four sets of holes.
3. Attach throttle linkage and have an assistant get in the boat and fully actuate the throttle controls. Make the necessary adjustments to the throttle linkage to ensure that the throttle plates are vertical when the throttle control is wide open. Work throttle linkage back and forth several times to ensure it operates smoothly with no binding or sticking.

DANGER! STICKING THROTTLE MAY RESULT IN UNCONTROLLED ENGINE OR BOAT SPEED. THIS COULD CAUSE PROPERTY DAMAGE, PERSONAL INJURY, OR DEATH. A STICKING THROTTLE MAY BE CAUSED BY IMPROPERLY INSTALLED THROTTLE CABLES, LACK OF CLEARANCE FOR ANY OF THE THROTTLE LINKAGE, OR BY BINDING THROTTLE LINKAGE. CHECK ALL THROTTLE CABLES FOR PROPER INSTALLATION AND ALIGNMENT AND ACTUATE THE THROTTLE TO CHECK FOR ANY POTENTIAL BINDING OR CLEARANCE PROBLEMS AND REPAIR ANY PROBLEMS.

NOTE: Ensure that the factory shift interrupt (if equipped) has been properly reconnected, is in proper working order, and does not cause any throttle actuation problems.

8.4 Fuel Pump Installation

1. Install one end of the brass T-fitting onto the threaded adapter fitting that is on the pump. Be sure to use a small amount of pipe thread sealer on the threads and also use two wrenches when tightening the fittings so no force is applied to the pump body.
2. Install a 3/8" hose fitting in the other end of the T-fitting.
3. Install the 1/4" barbed hose fitting or the pipe plug into the middle opening of the T-fitting. Use the hose fitting if routing the return line to the inlet of the pump. Use the plug if routing the return line back to the tank. See the return line installation section for explanation of return line options.
4. Pursuant to Coast Guard regulations, the electric fuel pump must be mounted directly to the engine or within 12" of the engine. In addition, **the pump should be mounted as low as possible** to prevent excessive noise and potential vapor lock problems. Install the small cushioned clamp around the center portion of the pump body. Mount the pump and clamp assembly onto the engine or within 12" of the engine using the hole provided in the clamp.

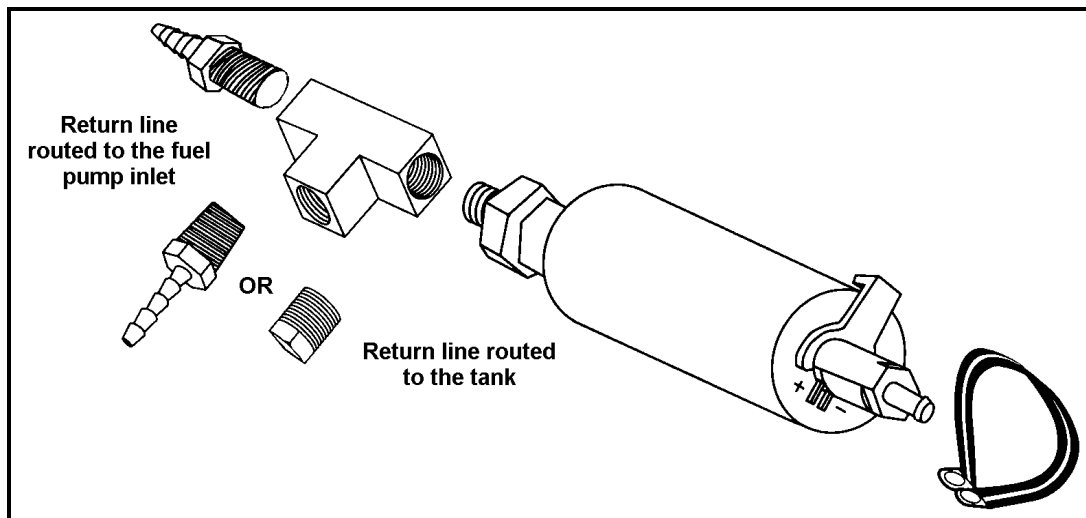

Figure 5

DANGER! TAKE PRECAUTIONS TO ENSURE THAT ALL FUEL LINE ROUTINGS ARE AWAY FROM HEAT SOURCES, SUCH AS THE ENGINE OR EXHAUST SYSTEM. FAILURE TO DO SO COULD RESULT IN A FIRE OR EXPLOSION HAZARD AND CAUSE PROPERTY DAMAGE, SERIOUS INJURY, AND/OR DEATH.

WARNING! Marine fuel systems use an anti-siphon valve. A factory carburetor anti-siphon valve may not work properly with a *PRO-JECTION* fuel system. The user may experience high levels of noise and/or vapor lock problems due to the anti-siphon valve being too restrictive. The anti-siphon valve should be replaced with a high flow capacity valve.

8.5 Fuel Pump and Throttle Body Filter

1. The fuel filter should be plumbed in between the electric pump outlet and the inlet fitting of the TBI. Install the large cushioned clamp around the center of the filter. Position the filter so the fuel hoses can be routed without kinks or sharp bends.

2. Start by cutting two sections of 3/8" fuel hose. One piece goes from the pump outlet to the filter and the other from the filter of the TBI inlet. Be sure the arrow on the filter indicating flow direction.
3. Push the hoses onto the filter all the way until they contact the filter body. Secure the hoses with clamps.
4. Connect the free ends of the hoses to the TBI inlet and the Pump outlet and secure with hose clamps.
5. Conveniently mount the filter using the fuel filter clamp.
6. Use the existing boat fuel filter or a OMC[®] filter kit part number 174176 or equivalent. The purpose of this filter is to protect the fuel pump from particles of dirt or other foreign material. The filter should be installed with the arrow on the filter pointing in the direction of the fuel flow. Secure the ends of the fuel lines with U.S.C.G. approved hose clamps.

8.6 Return Line Installation

The Holley digital **PRO-JECTION** System requires a return fuel line to the fuel tank so that unused fuel can be routed from the throttle body. There are two methods of installing a return line on a boat. The preferred method is to run a hose or line from the throttle body outlet back to the fuel tank. This can be done only if the return line fittings are already on the fuel tank. If a return line does not currently exist on the boat, the user may want to remove the fuel tank and modify it with an additional fitting of 1/4" I.D. minimum. The tank should be cleaned if removed and modified. The other method is used when there is no access to the tank. The return line must then be routed from the throttle body outlet back to the inlet side of the electric fuel pump. A minimum size of 1/4" I.D. is recommended for the return fuel line. Determine if the fuel system return lines will be routed using a return to the fuel tank system, or a return to the inlet side of fuel pump system. See Figure 6 for a diagram of the two fuel system configurations. Once a determination has been made, go to the section below required for your installation and follow the installation steps.

DANGER! ALL FUEL LINES MUST BE U.S.C.G. APPROVED. METALLIC LINES MUST BE MADE OF SEAMLESS ANNEALED COPPER, STAINLESS STEEL, NICKEL COPPER, OR COPPER NICKEL AND EXCEPT FOR CORRUGATED FLEXIBLE LINE, HAVE A MINIMUM WALL THICKNESS OF .029 INCHES. RUBBER HOSE MUST BE MARKED "U.S.C.G. TYPE A1". UNITED STATES COAST GUARD APPROVED HOSE CLAMPS MUST ALSO BE USED. USE OF AUTOMOTIVE GRADE FUEL LINES COULD CAUSE A FIRE OR EXPLOSION HAZARD WHICH COULD CAUSE PROPERTY DAMAGE, SERIOUS INJURY, AND/OR DEATH.

WARNING! Use only approved fuel lines. Follow all U.S.C.G. rules and regulations. The return fuel line should enter the fuel tank at the "fuel level sending unit flange" or at the "filler neck". The filler neck or sending unit must be removed from the tank to perform this operation.

DANGER! PROPER INSTALLATION OF THE FUEL RETURN LINE MAY NECESSITATE COMPLETE REMOVAL OF THE FUEL TANK. THIS WORK SHOULD BE DONE BY A FUEL TANK SPECIALIST, WHO HAS BEEN TRAINED IN THIS WORK AND IS FAMILIAR WITH SAFETY REGULATIONS AND PRECAUTIONS NECESSARY TO DO THIS WORK. IF A PERSON ATTEMPTS THIS WORK WHO IS NOT FAMILIAR WITH THE SAFETY REGULATIONS AND PRECAUTIONS, AN EXPLOSION HAZARD MAY RESULT IN PROPERTY DAMAGE, SERIOUS INJURY, AND/OR DEATH.

NOTE: Anchor all fuel lines securely at 1-½ foot intervals. The use of U.S.C.G. approved fuel line tubing will afford maximum fuel line protection against premature wearing due to flexing, temperature extremes, salt water, weather, etc.

Attach a section of 5/16" hose to the outlet of the throttle body and secure with a hose clamp. Run the other end to either the fuel tank (Method 1) or the inlet of the pump at the T-fitting as previously discussed in earlier text (Method 2). Secure with clamps.

NOTE: 1/4" U.S.C.G. approved hose is included with the kit, should it be required for specific applications.

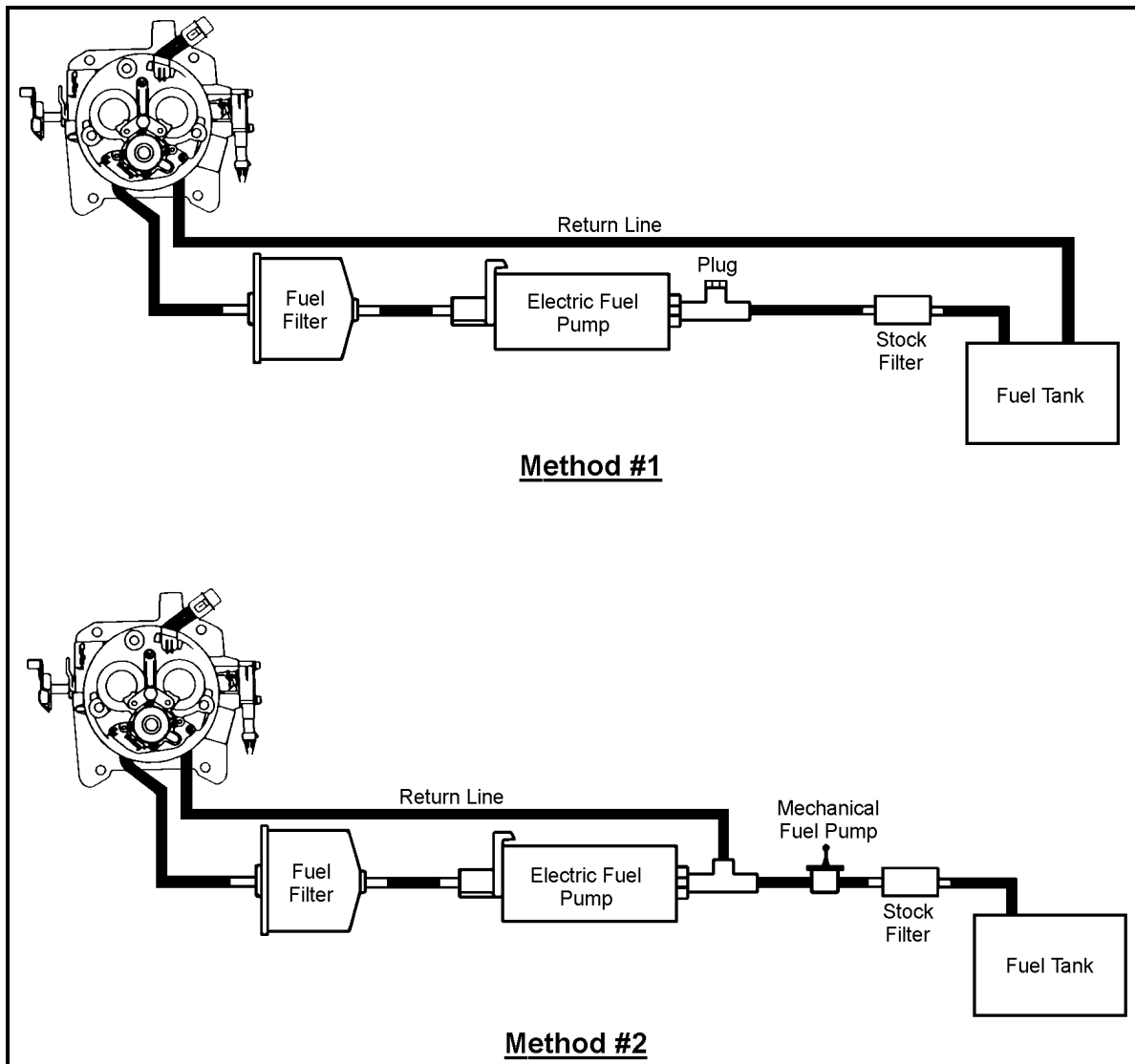

Figure 6

8.7 Inlet Fuel Line Installation

8.7.1 Installation with Fuel Return Line to Fuel Tank

The mechanical pump should not be used when the fuel return line goes to the fuel tank. Route a section of 3/8" hose from the boat fuel tank and fuel filter to the barbed fitting on the inlet of the **PRO-JECTION** electric fuel pump. Secure with clamps at each end of the hose. The stock pump should be removed and replaced with a block-off plate. Plug the fume tube in the throttle body.

8.7.2 Installation with Fuel Return Line to Electric Pump

Holley recommends that the mechanical pump be removed in this case. However, the pump can be optionally retained if the user wants to supply the electric pump with the mechanical pump. Install the 3/8" hose from the boat fuel tank and fuel filter to the 3/8" hose barb on the tee fitting. Then install the 3/8" hose from the tee fitting to the inlet of the **PRO-JECTION** electric fuel pump. Secure with clamps. Install the vent hose from the mechanical fuel pump (if equipped) to the fuel fume tube on the TBI.

WARNING! Be sure that there is a fuel filter between the fuel tank and pump(s). If one must be added, use an OMC® filter kit number 174176 or equivalent.

8.8 Coolant Temperature Sensor

Install the temperature sensor in a water passage of the intake manifold. Most intake manifolds have a plug that can be removed for installation of a temperature sensor. In addition, some cylinder heads have a plug that can be removed for installation of a temperature sensor. **DO NOT** install the sensor in the thermostat housing. The sensor must be located so that it is in contact with coolant on the lower side of the thermostat. If a location cannot be found, a metal tee fitting may be installed at the boat's temperature gauge sensor, if so equipped. Then the gauge and **PRO-JECTION** temperature sensor can be installed into the tee fitting. **DO NOT** use any pipe sealer on the threads that may degrade or reduce the ground connection of the sensor. Tighten the sensor to 15 ft./lbs. torque.

9.0 CLOSED LOOP INSTALLATION AND CONNECTION (OPTIONAL):

The digital ECU is designed to utilize a heated, three-wire oxygen sensor to operate the system in a closed loop mode. When operating in a closed loop mode, the electronic control ECU utilizes a reference signal from the oxygen sensor to determine whether the engine is running too rich or too lean. The ECU then adjusts the fuel delivery to maintain a stoichiometric fuel delivery (14.7:1 Air / Fuel Ratio).

NOTE: The installation of an oxygen sensor will operate with the digital ECU. This requires use of the Holley Digital **PRO-JECTION 2D** Closed Loop Kit for 1 and 2-Barrel Applications, P/N 534-54.

WARNING: If you are currently using a Holley analog closed loop kit, P/N 534-27, all electrical wiring connecting to this kit must be removed and replaced with a new wiring harness, Holley P/N 534-56. Failure to replace this wiring harness will result in improper fuel delivery and possible damage to ECU.

WARNING! Use only unleaded fuels when operating an oxygen sensor. Use of Leaded fuels will DESTROY the oxygen sensor and will result in incorrect exhaust gas oxygen readings, which may cause poor performance and cause serious engine damage.

WARNING! The use of some RTV Silicone sealant will destroy the oxygen sensor. Ensure that the RTV silicone sealant that you use is compatible with oxygen sensor vehicles. To determine compatibility, check the packaging of your RTV silicone or contact the sealant manufacturer.

WARNING! An experienced inboard mechanic should be used for installation of the oxygen sensor. Inboard engine exhaust manifolds have water passages inside them for noise and cooling purposes. An improperly drilled manifold will result in water getting into the oxygen sensor causing it to be destroyed and destroying the exhaust manifold. The oxygen sensor should be installed as far from a water location as possible and as close to an exhaust port as possible.

NOTE: The oxygen sensor, if used, should be installed by someone with experience with inboard boat engine exhaust systems. Any competent inboard repair shop should be able to perform this task at a minimum cost.

Locate a position for the oxygen sensor as close to the engine as possible. Pick a location that allows easy installation and removal of the oxygen sensor. Figures 7 & 8 show the location used by Holley engineers during development of the Marine **PRO-JECTION** systems. The oxygen sensor was mounted in the exhaust port farthest from the water injection hose and riser tube at the top of the picture. This location was chosen to prevent water that is pumped into the exhaust system from running back down the riser tube and into the exhaust manifold. This can wet the oxygen sensor and cause damage to the oxygen sensor. The close-up shows that the hole for the oxygen sensor was drilled through an area of the manifold that does not have any water passages. This should be done to prevent any possibility of water leakage from the wet areas of the manifold to the dry areas.

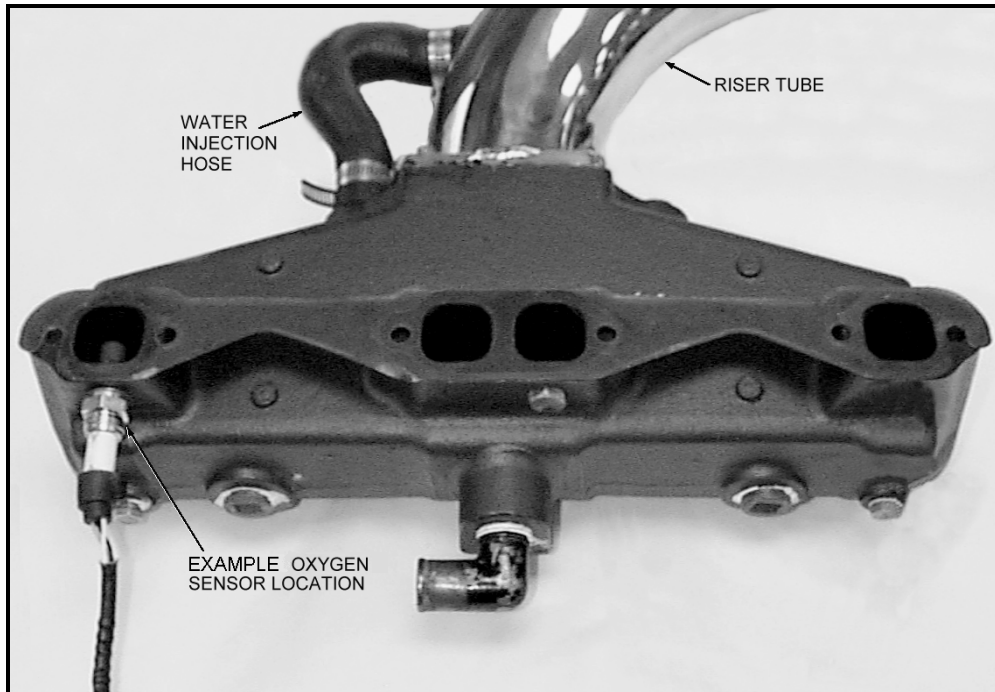

Figure 7



Figure 8

1. If the oxygen sensor is being installed directly into the exhaust manifold, the manifold will have to be drilled and tapped for the oxygen sensor threads. The location for the oxygen sensor should be chosen very carefully. The sensor must be located in an area that can be drilled without passing through any of the manifold water jackets. The oxygen sensor must be kept dry for proper operation and should not pass through any water passages to prevent any water leakage. Drill a hole in the location picked for the sensor using a 5/8 inch drill size.
2. Tap the hole using a m18 x 1.5-5H metric tap.
3. Install the oxygen sensor into the threaded hole and tighten securely. Care should be taken not to over tighten the sensor when aluminum manifolds have been used. It is a good idea to add anti-seize to the threads to aid if oxygen sensor removal is necessary.

10.0 MOUNTING THE ELECTRONIC CONTROL UNIT (ECU):

DANGER! ALWAYS DISCONNECT YOUR BOATS BATTERY BEFORE PERFORMING ANY WORK ON THE ELECTRICAL OR FUEL SYSTEM. FAILURE TO DO SO MAY PRODUCE SPARKS, CAUSING A FIRE OR EXPLOSION, RESULTING IN PROPERTY DAMAGE, PERSONAL INJURY, AND/OR DEATH.

WARNING! Do not open the ECU. The digital electronics contained within this ECU are sensitive to static electricity. Opening this ECU WILL VOID THE WARRANTY.

WARNING! Do not mount the ECU in an enclosed area. Mount the ECU in an area that will allow air to flow freely across the ECU to dissipate heat generated by the ECU.

WARNING! When mounting the ECU, care must be taken that none of your boats other systems, such as the electrical system, are damaged by either drilling holes or using mounting screws. Always check on the other side of the location that is to be drilled to ensure that no damage will occur.

WARNING! Do NOT mount the ECU in the engine compartment. The ECU is not designed for the environment (heat, moisture) present in the engine compartment. Premature failure of the ECU will result.

WARNING! The *PRO-JECTION 2D* system must be appropriately grounded to ensure proper system performance and to prevent any damage to the system.

NOTE: All connections shown MUST be made in order for the *PRO-JECTION 2D* system to operate properly.

1. Pick a suitable location on the interior of the boat in which the ECU can be mounted. Ensure the mounting location allows for sufficient length of the wiring harness and clearance for connectors and the adjustment knobs on the front of the ECU are accessible before mounting the ECU.
2. Using the ECU base plate as a template, drill 4 pilot holes, ensuring that no damage will result to any of your boats other systems.
3. Mount the ECU with 4 self-starting sheet metal screws (not included).

11.0 ENGINE WIRING HARNESS

1. At a location near the ECU mounting, pick a suitable location on the engine compartment bulkhead for the wiring harness to pass through. A 2" diameter hole will be required for the wiring harness. Check both sides of the bulkhead for interference.

WARNING! Before drilling, check both sides of the bulkhead for possible interference with electrical systems, etc. Failure to do so can result in damage to one of the boat systems.

2. Use a 2" hole saw (available at any hardware store) or a punch out tool to cut through the bulkhead, as necessary.
3. Feed the wiring harness from the location of the ECU to the engine compartment. Check to ensure sufficient length of harness is available for attaching to the ECU.
4. Slit a 2" grommet and position around the wiring harness. Slip the grommet into the 2" hole to prevent the wiring harness from chaffing. A light application of WD-40 on the grommet will ease the installation.
5. Connect the wiring harness to the ECU. Push the plug into the ECU until the lock snaps into position.

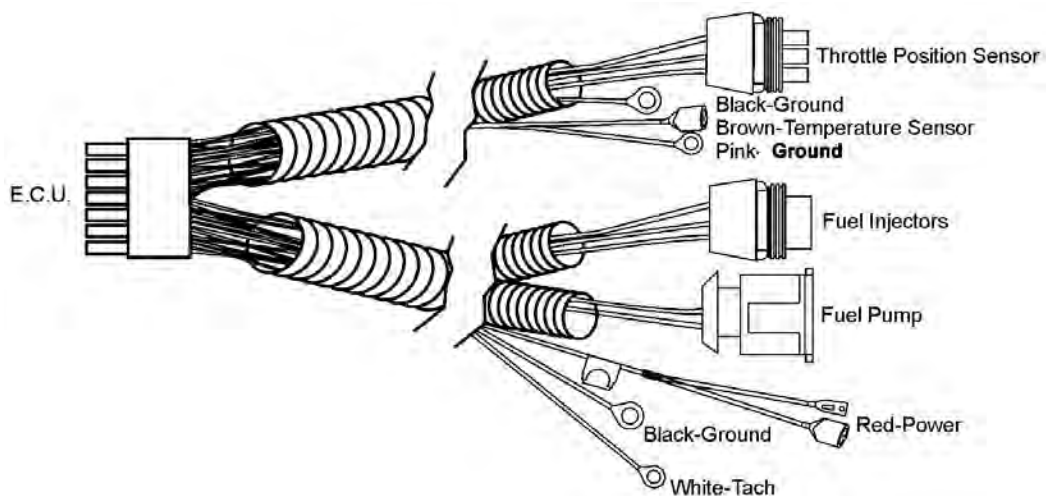

Figure 9

12.0 ELECTRICAL CONNECTIONS

The cable assembly plugs into the ECU and also connects to the throttle body, fuel pump, sensors, electrical power, and ground. Apply a small amount of dielectric grease to all electrical terminals and connections.

WARNING! Keep all wires away from hot or moving parts as much as possible. Your kit includes cable ties to secure wires clear. Bare or frayed wires can result in electrical short circuits, which can cause system failure.

Start with the bundle containing the three-way male connector and the black and brown wires. See Figure 9. Plug the three-way connector with the grey, blue and black wires into the throttle position sensor on the TBI until it locks in place. The black wire with the ring terminal must be secured to an engine block or intake manifold bolt. Be sure the connection is free from rust dirt or paint. Next connect the brown wire to the temperature sensor. The pink wire must go to ground. The voltage on this terminal must be zero when the engine is off or running.

NOTE: Good grounding is essential to make this system operate correctly.

The other bundle in the harness contains the four-way connector with two red wires, a violet wire, and an orange wire. Plug this four-way connector and push this into the fuel pump until it is secure. The single black wire with a ring terminal is the ground. Bolt this to the engine just as you did with the previous black wire. The white wire with the ring terminal is the tach signal input to the ECU. This wire is usually connected to the (-) side of the ignition coil. If hooking up to a GM HEI ignition, a 1/4" female terminal will have to be used in place of the ring terminal before connecting to the tack output on the distributor cap. If an aftermarket ignition is used and has a jack labeled "tach signal" or similar, connect the white wire to this point. The last wire to connect is the red wire with the fuse holder. This is the main power lead for the system and must be wired to a source that is energized during the on and crank positions of the ignition switch. Reconnect the battery momentarily and use a voltmeter to find this. Be sure to disconnect the battery after a suitable power source is located. The harness is designed to directly hook up to the IGN terminal of a GM HEI distributor. See Figure 10. For other types of ignition systems, power must be found elsewhere. In this case, trim the fuse holder cable as shown in Figure 11. In some cases, a wire must be run from the boat ignition switch back to the fuse holder on the harness. Use 14 gauge wire or larger if this is done.

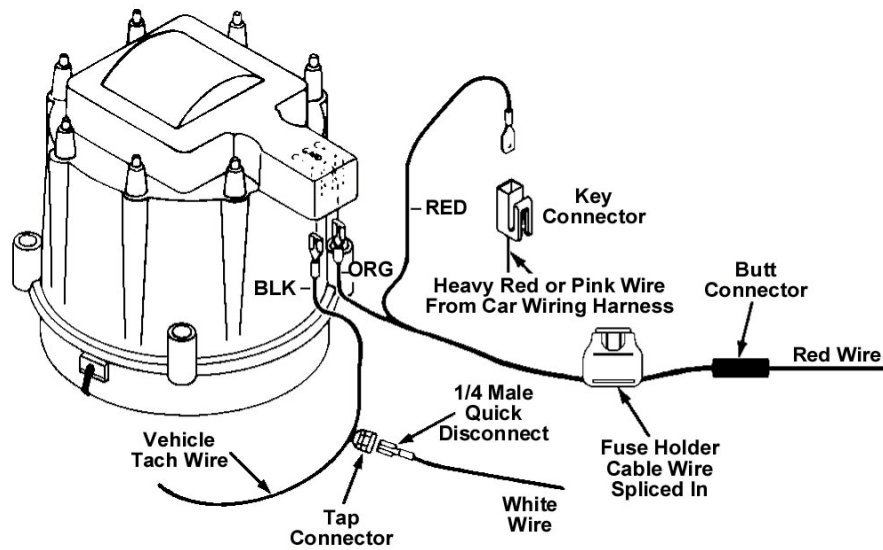

HEI SYSTEMS

Figure 10

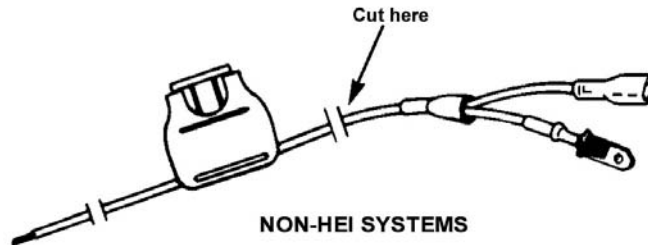

NON-HEI SYSTEMS

Figure 11

WARNING! For proper operation, the voltage on the fuse holder wire should be 12-15 volts while the engine is running and should remain above 8.5 volts while the engine is being started. Low voltage will result in poor operation or an inoperative system. Double check the voltage after the installation is complete.

WARNING! The use of solid core ignition wires may adversely affect the function of the electronic control unit. We recommend the use of suppression or spiral core wires.

NOTE: Alternator output voltage is critical with the Pro-Jection system. If the alternator is not supplying specification output (about 14 volts) when the engine is running, repair the system so it does supply the correct voltage.

13.0 FINAL CONNECTIONS

Plug the white 12-pin connector into the ECU. Install the harness bracket onto the ECU to hold the connector in place. To do so, remove the two lower cover screws, install the bracket, and replace the screws.

Shown in Figure 12 is the proper installation of the distribution ring on the throttle body. Be sure the tabs point upward and rest along the injector pods. The injector pod screw closest to the TPS switch must be removed and reinstalled to hold the distribution ring in place.

WARNING! It is important for the distribution ring to be properly installed and retained. Failure to do so will cause inadequate seal between the throttle body and flame arrestor and may be a fire hazard in the event of a backfire.

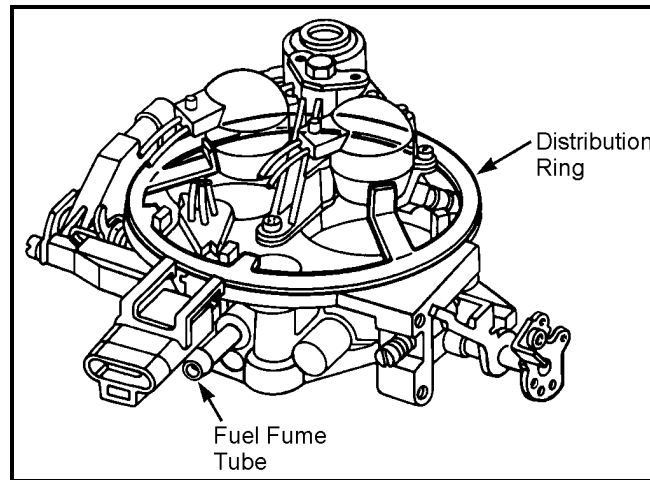

Figure 12

14.0 OPERATIONAL OVERVIEW OF THE DIGITAL ECU

This digital ECU is programmed at the factory with fuel maps. The ECU utilizes inputs from various sensors and from the adjustment knobs located on the front of the ECU to calculate the appropriate fuel delivery to the engine.

When the ignition switch is in the "On" position, battery power is applied to the red wire of the ECU, fuel pump (+) terminal and one side of each injector coil. Upon initial power up, the fuel pump will run for a couple of seconds to help prime the fuel lines. The ECU controls the pump by grounding the green wire going to the (-) terminal of the pump. As the engine is being started, battery power is applied to the pink wire, which enables the ECU to operate the fuel pump, and pulses the injectors, so fuel is delivered into the throttle body. After the engine starts up and the ignition switch is released from the crank position, the ECU relies on tach signals from the white wire to operate the pump and injectors to run the engine. If for some reason the engine stalls, this is most likely due to the absence of tach signals, which causes the ECU to shut off the injectors and the fuel pump.

The temperature sensor is designed to have a high resistance when cold (about 10K ohms at 20°F) and a low resistance when warm (about 200 ohms at 200°F). This sensor tells the ECU to deliver a richer fuel mixture during cold engine operation and gradually leans out at the engine warms up. The brown wire can be grounded to disable the choke function. This may be required if the coolant temperature is less than 150 when the engine is fully warmed up.

The throttle position sensor (TPS) tells the ECU how far and how fast the throttle is opened. The ECU sends a 5 volt reference signal to the TPS along the gray wire and the voltage on the blue wire varies depending on how far the throttle is opened. A low voltage appears at idle with the voltage increasing as the throttle is moved to open. A "CLEAR FLOOD" mode has also been programmed into the ECU to aid in vehicle startup in case excessive fuel has entered the intake manifold. Should the engine flood during start up, the clear flood mode can be initialized by turning the ignition off, opening the throttles fully and cranking the engine until it starts. There is also a back-up mode, which allows the boat to be driven in the event of TPS failure. If the TPS

should "open circuit", causing a lean condition, the back up automatically takes place. If the TPS "short circuits", causing a rich condition, you must remove the wire harness connector from the TPS. The idle will be richer and top speed will be limited in this mode. DO NOT operate for an extended period of time in this mode.

WARNING! The throttle position sensor may become damaged if exposed directly to liquid. Protect the TPS when washing the engine.

The oxygen sensor provides information on whether the engine is running rich or lean. Even though the oxygen sensor is heated, the ECU will continue to operate in an open loop mode for a short period of time after initial start-up. This combined information is then used by the ECU to adjust the fuel delivery to the engine.

In addition to the information provided to the ECU by the various sensors, the user is also able to adjust the fuel delivery through the use of the five adjustment knobs on the front of the ECU. The user is able to adjust fuel delivery for Choke, Accelerator Pump, Idle, Main, and High RPM settings. A detailed description of each adjustment is given below. Refer to Figure 13 during the discussion of each of the adjustments.

The fuel map that is programmed into the digital ECU is comprised of 256 individual points. Each point has a throttle position and rpm value assigned to it. These values are used by the digital ECU to determine the appropriate fuel delivery when the system is in operation

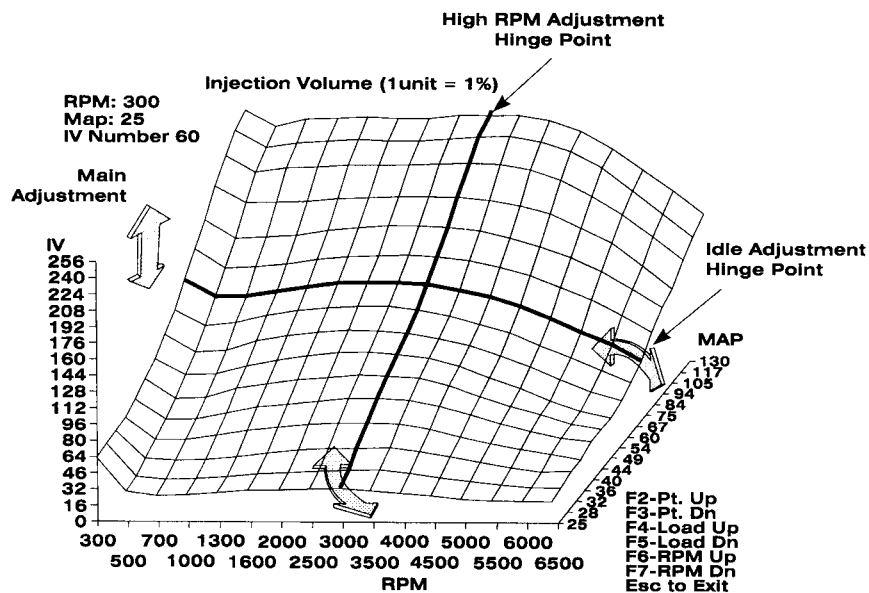

Fuel Map Areas of Adjustment
Figure 13

14.1 Main

The MAIN adjustment knob allows the user to adjust the fuel delivery of the entire fuel map 50% above or below the values set at the factory. Rotating the knob clockwise will raise the fuel map vertically, therefore increasing the fuel delivery for all points in the map. Rotating the knob counter-clockwise will lower the map vertically, therefore decreasing the fuel delivery for all points in the map.

NOTE: In tuning the system, the MAIN is the first value to be adjusted. All other adjustments are made AFTER the MAIN has been properly set.

14.2 Idle

The Idle adjustment knob allows the user to adjust the fuel delivery in the idle region of the fuel map 30% above or below the values that are set at the factory. This is accomplished by moving the lower part of the fuel map either up or down along a hinged horizontal line as indicated in Figure 13. Adjustments to the idle region of the fuel map are made AFTER the MAIN Adjustment knob has been properly adjusted. Turning the knob clockwise increases the fuel delivery, while a counter-clockwise rotation decreases the amount of fuel delivered to the engine during idle.

14.3 High RPM

The HIGH RPM adjustment knob allows the user to adjust the fuel delivery for engine speeds over 3000 rpm 50% above or below the values that are set at the factory. This is accomplished by moving the fuel map either up or down along a diagonal hinged line as indicated in Figure 13. Turning the adjustment knob clockwise increases the fuel delivery, while a counter-clockwise rotation decreases the amount of fuel delivered to the engine at high engine speeds.

14.4 ACCEL Pump

The ACCEL PUMP adjustment knob allows the user to adjust the addition of fuel for acceleration 50% above or below the value set at the factory. Rotating the adjustment knob clockwise results in additional fuel being added to the fuel enrichment set at the factory, while rotating the adjustment knob counter-clockwise will result in less fuel being added during acceleration. The proper adjustment is made while performing acceleration tests, which are described later on in this section.

14.5 Choke

The CHOKE adjustment knob allows the user to adjust the amount of fuel enrichment while the engine is warming up 20% above or below the value set at the factory. Rotating the adjustment knob clockwise will increase the amount of fuel added while the engine is warming up. Rotating the adjustment knob counter-clockwise will decrease the amount of fuel added while the engine is warming up.

15.0 BEFORE STARTING THE ENGINE

WARNING! The adjustment knobs on the front of the ECU are precision manufactured parts and do not require a great deal of force to turn. Do not apply excessive force to the adjustment knobs. Full adjustment range for the knobs is 3/4 of a turn.

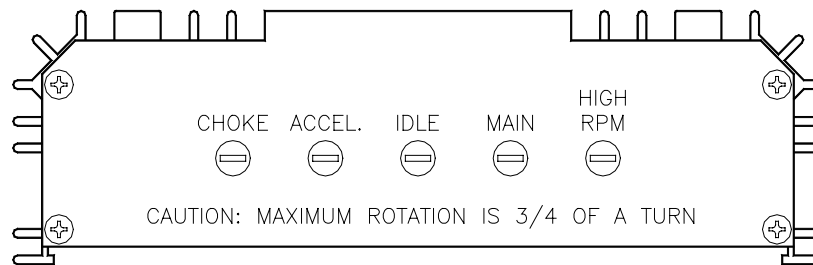

Figure 14

1. After all electrical connections have been made, double-check all connections to ensure that they are tight and secure.
2. Reconnect the battery.
3. If installed, remove the oxygen sensor harness from the digital ECU by unplugging the harness from the rear of the ECU.
4. Although the adjustment potentiometers on the front of the digital ECU were set at the factory in the null position, check to ensure that they were not moved. If necessary, rotate the potentiometers, so that they are positioned as in Figure 14.
5. Turn the ignition key to the "RUN" position. DO NOT START THE ENGINE. Listen for the fuel pump. The fuel pump should run for several seconds before shutting off.
6. Turn the ignition key to the "OFF" position.

16.0 SETTING THE MECHANICAL IDLE

The setting of the mechanical idle speed is critical in the operation of the Digital ECU and is best accomplished by using a tachometer. If your vehicle is not equipped with a tachometer, Holley highly recommends one be used. To adjust, follow the instructions carefully.

DANGER! ENSURE THE THROTTLE IS NOT STICKING. A STICKING THROTTLE MAY RESULT IN UNCONTROLLED ENGINE OR BOAT SPEED. THIS COULD CAUSE PROPERTY DAMAGE, PERSONAL INJURY, AND/OR DEATH.

1. Start the engine. With the engine running at idle, insert a flat blade screwdriver into the head of the idle adjustment screw located on the front of the throttle body on the driver's side of the vehicle.
2. Turn the idle adjustment screw clockwise to increase the engine idle speed, or counterclockwise to decrease the engine idle speed, until the engine speed is approximately 750 rpm.

17.0 SETTING THE THROTTLE POSITION SENSOR (TPS)

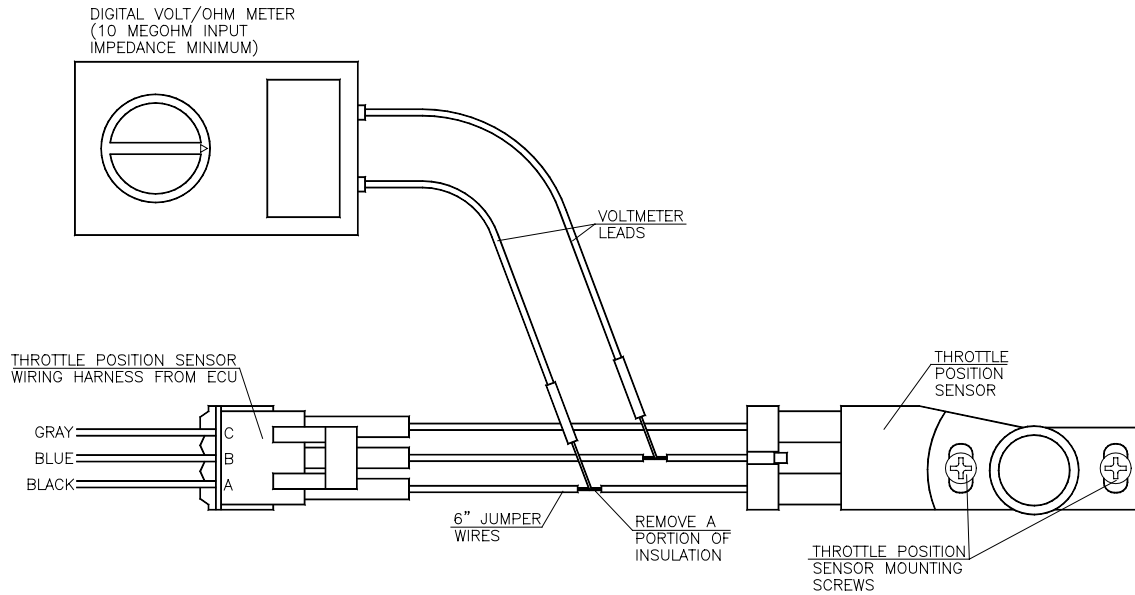

Figure 15

The setting of the throttle position sensor is critical in the operation of the Digital ECU and is best accomplished by using a digital voltmeter. To adjust, follow the instructions carefully.

NOTE: Fuel delivery can **NOT BE ADJUSTED** by changing the positions of the TPS. The TPS must be set in the position outlined below.

1. Unplug the three-position connector from the TPS and attach jumper wires between the TPS and the connector.
2. Remove a portion of the insulation on the jumper wires connecting to both the black and the blue wires leading to the TPS as shown in Figure 15.
3. Attach the positive (+) lead of a digital volt meter to the jumper wire connected to the blue wire.
4. Attach the negative (-) lead of a digital volt meter to the jumper wire connected to the black wire.
5. Turn the ignition key to the "RUN" position. Do not start the engine.
6. Slightly loosen the two screws that hold the TPS in place with a Phillips screwdriver.
7. Adjust the TPS until the voltage between the blue and black wire measures 0.63 to 0.65 volts.
8. Tighten the two screws that hold the TPS in place and verify that the voltage between the blue and black wires on the TPS continues to read between 0.63 to 0.65 volts. Readjust the TPS if necessary to obtain this voltage reading.
9. Turn the ignition key to the "OFF" position.
10. Remove the jumper wires and plug the three position connector back into the TPS, ensuring that the safety latch snap into place.

NOTE: Once the TPS and mechanical idle have been set, you are ready to tune the system.

18.0 TUNING THE DIGITAL ECU FOR PERFORMANCE

WARNING! The adjustment knobs on the front of the ECU are precision manufactured parts and do not require a great deal of force to turn. Do not apply excessive force to the adjustment knobs. Full adjustment range for the knobs is 3/4 of a turn.

WARNING! Initial tuning of the system should be completed in an area free of other boats.

NOTE: A small change in the adjustment knob settings will have a large effect on the amount of fuel delivered to the engine under various operating conditions. Make small adjustments to the adjustment knob setting when tuning the system.

NOTE: Holley recommends the use of a Rich/Lean indicator that will provide information relative to the air and fuel delivery to the engine when tuning the system. A Rich/Lean indicator with an Oxygen Sensor is available from Holley as P/N 534-51 and without an Oxygen Sensor as P/N 534-50. Use P/N 534-50 if you have already installed a closed loop kit.

NOTE: When tuning the system for future closed loop operation, all potentiometer settings must be set slightly richer than stoichiometric in case an oxygen sensor failure should occur. This will prevent damage to your engine due to lean operating conditions.

NOTE: The tuning of the digital ECU is critical in the operation of the fuel injection system and is best accomplished by using a tachometer. If your vehicle is not equipped with a tachometer, Holley highly recommends one be used. To adjust, follow the instructions carefully.

18.1 Tuning the Main

As described earlier, the MAIN adjustment knob controls the fuel delivery across the entire operating range by raising or lowering the fuel delivery 50% above or below the values programmed at the factory. Therefore, adjustments made with the MAIN adjustment knob will affect the fuel delivery in all modes of engine operation.

1. Disconnect the closed loop harness, if installed, from the rear of the digital ECU. Initial tuning should be completed with the system operating in open loop mode.
2. Start the engine and allow the engine to reach operating temperature.
3. Turn the adjustment knob labeled MAIN, clockwise until the engine rpm reaches a maximum value and the engine rpm just begins to drop. If your vehicle is equipped with a Holley rich / lean indicator, adjust the MAIN adjustment knob until the green center light on the unit remains stable.
4. Rotate the main adjustment knob counter-clockwise back to the point where the engine rpm started to drop, until maximum engine rpm is once again achieved.
5. Let off the throttle and allow the engine to return to idle. Steps 1 through 5 have given the MAIN a coarse setting, but now we must continue to tune the MAIN by putting a load on the engine. This will most likely cause the MAIN to go lean.
6. From idle, begin to accelerate the boat until the engine speed is up to 3000 RPM. Note the performance of the engine. Watch for any signs of black smoke, which indicates a rich condition. If it bogs down the engine may be lean.
7. Bring the boat to a complete stop. Increase or decrease the amount of fuel delivered during the acceleration by turning the MAIN adjustment knob either clockwise or counter-clockwise. If your vehicle is equipped with a Rich / Lean indicator, adjust the MAIN adjustment knob until the meter indicates a slightly rich fuel mixture through out the RPM range.
8. Adjust the MAIN adjustment knob accordingly and continue performing acceleration tests until you achieve a slightly rich condition through out the entire RPM range of the engine. This will give you a balanced main map.

18.2 Tuning the Idle

Adjustments made to the IDLE adjustment knob will affect the area of the fuel map that relates to the idle operation of the vehicle.

1. Turn the IDLE adjustment knob either clockwise or counter-clockwise until maximum engine rpm is achieved and the engine idles smoothly. If you are using a rich / lean indicator to tune the system, turn the IDLE adjustment knob until the green center LED is lit.

NOTE: Many engines require a richer fuel mixture at idle. Therefore it may not be possible to maintain the fuel mixture at a stoichiometric level while maintaining the engine at a smooth idle. Adjust the idle fuel delivery that best meets your engine's requirements.

NOTE: If you are unable to adjust the IDLE adjustment knob to achieve a proper idle, it may be necessary to once again adjust the mechanical idle adjustment screw. This is located on the driver's side front of the throttle body. Adjust this to a higher setting, as described on Page 19 of this manual. If you change the setting of the idle adjustment screw, it will be necessary to once again adjust the TPS to the proper idle setting as described on Page 19 of this manual. Once the TPS and idle have been adjusted, it will also be necessary to adjust the MAIN adjustment knob as described on page 20.

2. Now return to **SETTING THE THROTTLE POSITION SENSOR (TPS)** and follow the steps outlined to adjust the TPS again. Once the TPS has been reset return to **TUNING THE MAIN** and adjust again. Then return to step one of this section and tune the idle again.

18.3 Tuning the ACCEL

The ACCEL adjustment knob controls the amount of fuel that is added to the engine when accelerating. Adjustments made here allow for a quick, crisp response during acceleration.

1. Shift the transmission into gear and slowly accelerate the boat to plane.
2. Quickly open the throttle and note the performance of the engine. If the engine bogs (falls flat) and black smoke comes out of the exhaust, the ACCEL adjustment is set too high. If the engine bogs and no black smoke comes out of the exhaust, the ACCEL adjustment is set too low.
3. Adjust the ACCEL adjustment knob accordingly and continue performing acceleration tests you achieve a quick, crisp response during acceleration and no black smoke comes from the exhaust.

18.4 Tuning the High RPM

The HIGH RPM adjustment knob changes the fuel delivery to the engine at engine speeds over 3000 rpm.

NOTE: To properly set the HIGH RPM setting, it will be necessary to operate your engine at a steady speed while determining the proper fuel delivery.

1. Begin to smoothly accelerate the boat until the engine speed is above 3000 RPM. Now quickly press the accelerator and perform a hard acceleration. Note the performance of the engine.
2. Bring the boat to a complete stop. Increase or decrease the amount of fuel delivered during high engine speeds by turning the HIGH RPM adjustment knob either clockwise or counter-clockwise. If your vehicle is equipped with a Rich / Lean indicator, adjust the HIGH RPM adjustment knob until the meter indicates a slightly rich fuel mixture at high engine speeds.
3. Adjust the HIGH RPM adjustment knob accordingly and continue performing acceleration tests until you achieve a quick, crisp response during acceleration.

18.5 Tuning the Choke

The CHOKE adjustment knob controls the fuel delivery to the engine during a cold start. Adjustment to the CHOKE should be made after the engine has cooled down completely.

1. After the engine has cooled down completely (Holley recommends allowing the engine to sit overnight), start the engine.
2. Immediately after starting the engine, shift the transmission into gear and accelerate slowly.
3. Turn the CHOKE adjustment knob to achieve a clean drive-away from a cold start. Several cold starts will be necessary to zero in on the proper CHOKE setting.

19.0 MAINTENANCE AND STORAGE

The Holley digital **PRO-JECTION** system is designed to give many hours of service with minimal maintenance. The following periodic maintenance is required to ensure your continued satisfaction with the system.

1. Use a good grade of fuel. Always use a quality gasoline from a reputable service station. Pick service stations that pump large quantities of fuel to ensure fresh gas and less contamination from underground tanks.
2. Add Holley fuel system cleaner to the gas tank every 3 months according to the directions on the system cleaner. This will keep injector patterns optimal for best performance and economy.
3. Change both fuel filters annually or at 500 hours. Use only filters rated for high-pressure fuel injection service. The Holley part number for the large fuel filter is 562-1.
4. To ensure safety, performance, and reliability, periodically check all fuel lines for cracks and replace as needed.
5. Be sure all electrical connections are secure and wires are away from moving parts. Apply a fresh coat of silicone dielectric grease to all electrical terminals to help conductivity and reduce corrosion.
6. If a drop in performance is noticed, a dirty fuel filter may be the problem. Change, as required.
7. During extended periods of vessel storage (60 days or more) gasoline might deteriorate due to oxidation. This can damage rubber and other polymers in the fuel system. It may also clog fuel injectors. A commercially available fuel stabilizer should be added to the vessel's fuel tank whenever actual or expected storage period exceeds 60 days. Follow the product instructions for the amount of additive to use. The engine should be operated at idle for a minimum of ten minutes after the addition of the stabilizer to assure that it reaches the throttle body.

20.0 TROUBLESHOOTING AND COMPONENT TESTING

Double check all wiring connections and installed components for their proper operation before replacing any parts. If you suspect an unlikely ECU failure, check all other system components before replacing a component.

	PROBLEM	POSSIBLE CAUSE	SOLUTION
A	Fuel Pump Does Not Operate	<ul style="list-style-type: none"> - Open or blown fuse - Poor ground connection - Loose connector - Broken or burned wire - No power to pump from ECU - No power to the ECU - Faulty fuel pump 	<ul style="list-style-type: none"> - Replace fuse - Clean ground location and tighten connection - Check Connection - Replace or repair wire - Check for voltage and ground at the pump. If proper voltage is present, replace the ECU. - Check power out from relay. Test relay and replace, if faulty. See Testing the Power Relay section. - Replace the fuel pump
B	No Fuel From the Injectors	<ul style="list-style-type: none"> - Open or blown fuse - Poor ground connection - No power to the ECU - Loose injector harness connection - No fuel in tank - Low fuel pressure - Kinked or restricted fuel line - Fuel pump does not operate - No TACH signal - Faulty ECU 	<ul style="list-style-type: none"> - Replace fuse - Clean ground location and tighten connection - Check power out from relay. Test relay and replace if faulty. See Testing the Power Relay section. - Inspect and clean connection, reconnect - Add fuel to tank - Install pressure gauges and adjust fuel pressure. See Adjusting Fuel Pressure section. - Repair kinks and remove obstructions from fuel line. - See Item A - Check for proper wire connection. See Electrical Connections Section 12.0 - Replace ECU
C	Engine starts but stalls after starter motor disengages	<ul style="list-style-type: none"> - No voltage to relay switched power input with ignition in "RUN" position - No TACH signal 	<ul style="list-style-type: none"> - Check switched power connection to relay with ignition in "RUN" position - Check for proper ignition system operation - Check for proper wire connection. See

			Electrical Connections Section 12.0
D	Injector flows fuel with ignition switch in the "RUN" position and engine not running	<ul style="list-style-type: none"> - Poor Engine ground wire connection - Leaky fuel injector 	<ul style="list-style-type: none"> - Clean ground location and tighten connection - Replace fuel injector
E	"CLEAR FLOOD" mode does not operate while cranking the engine	<ul style="list-style-type: none"> - Throttle does not open fully - Faulty TPS - Low voltage to ECU during cranking - ECU does not supply 5 volt signal to TPS 	<ul style="list-style-type: none"> - Check for interference between the throttle linkage and surrounding components. Adjust throttle linkage. - Test TPS. See Testing the TPS section. Replace TPS - Ensure that voltage to ECU is above 8 volts during cranking. Replace battery or starter - Check all wire connections. Replace ECU
F	Engine Runs Rich	<ul style="list-style-type: none"> - ECU adjustment knobs are set too high - High supply fuel pressure - High return fuel pressure - Incorrect TPS adjustment - Faulty TPS - Oxygen sensor is mounted incorrectly - Faulty oxygen sensor - Leaking fuel injector 	<ul style="list-style-type: none"> - Adjust knob settings. See Tuning section on Page 22 - Install pressure gauges and adjust fuel pressure. See Adjusting fuel pressure section. - Kinked or restricted fuel return line. Repair kinks and remove obstructions from fuel line. - Adjust TPS position. See Adjusting the TPS section on Page 21 - Test TPS. See Testing the TPS section. Replace TPS - See Optional Closed Loop System installation section on Page 14 - Replace the oxygen sensor - Replace fuel injector
G	Engine Runs Lean	<ul style="list-style-type: none"> - ECU adjustment knobs are set too low - Low supply fuel pressure - Incorrect TPS adjustment - Faulty TPS - Restricted Fuel Injector - Vacuum Leak - Water in fuel - Faulty oxygen sensor 	<ul style="list-style-type: none"> - Adjust knob settings. See Tuning section on Page 22 - Install pressure gauges and adjust fuel pressure. See Adjusting Fuel Pressure section. - Adjust TPS position. See Adjusting the TPS section on Page 21 - Test TPS. See Testing the TPS section. Replace TPS - Remove fuel injector and clean injector screen and throttle body. Replace injector - Locate vacuum leak and repair - Remove water from fuel with proper fuel additive. - Replace the oxygen sensor
H	Hard Starting (Cold Engine)	<ul style="list-style-type: none"> - "CHOKE" knob adjustment set too low - Non-functional coolant temperature sensor - Non-functional fast idle solenoid - Fuel pump not flowing fuel 	<ul style="list-style-type: none"> - Increase "CHOKE" setting - Test temperature sensor. See Testing the Temperature Sensor section. Replace sensor if necessary. - Check wire connection to solenoid - Test solenoid. See Testing the Fast Idle Solenoid section. Replace solenoid if necessary. - See Item A
I	Hard Starting (Warm Engine)	<ul style="list-style-type: none"> - Engine is flooding - Non-functional coolant temperature sensor - Fuel pump not flowing fuel 	<ul style="list-style-type: none"> - Use "CLEAR FLOOD" mode. Inspect injectors after shutting off engine for injector leakage. Replace leaking injectors - Test temperature sensor. See Testing the Temperature Sensor section. Replace sensor if necessary. - See Item A
J	Fuse blows repeatedly	<ul style="list-style-type: none"> - Improper fuse installed - Fuel pump motor is locked - Wire insulation is broken resulting in a short to ground - Faulty ECU 	<ul style="list-style-type: none"> - Install 10 Amp Fuse - Test Fuel Pump. See Item A - Inspect wiring harness and repair wire - Replace ECU
K	Low Fuel Pressure	<ul style="list-style-type: none"> - Low Voltage at fuel pump 	<ul style="list-style-type: none"> - Check voltage to pump from ECU. Inspect

		<ul style="list-style-type: none"> - Kinked or restricted fuel line - Faulty fuel pump - Throttle body pressure regulator improperly adjusted - Low fuel level in tank - Restrictive screen in tank 	<p>wiring harness. Check Battery voltage.</p> <ul style="list-style-type: none"> - Repair kinks and remove obstructions from fuel line. - See Item A - See Adjusting Fuel Pressure section
L	High Fuel Pressure	<ul style="list-style-type: none"> - Kinked or restricted fuel return line - Return line diameter too small - Throttle body pressure regulator improperly adjusted 	<ul style="list-style-type: none"> - Add fuel to tank - Clean fuel tank and increase screen size - Repair kinks and remove obstructions from fuel line - Replace fuel return line with larger diameter fuel line. - See Adjusting Fuel Pressure section

20.1 Adjusting the Fuel Pressure

The pressure regulator located at the rear of the throttle body is factory set at 15 PSI. A slight adjustment may be necessary to allow for proper system operation.

1. Install a pressure gauge into the fuel supply line. This gauge must be removed after the fuel pressure has been properly adjusted.
2. Start the engine and verify that the fuel lines do not leak. If any leaks are found, turn off the engine and repair the leaks before continuing.
3. Insert a 5/32" Allen wrench into the pressure regulator screw on the top of the throttle body.
4. Turn the screw into the throttle body to increase the fuel supply pressure or out of the throttle body to decrease the fuel supply pressure.

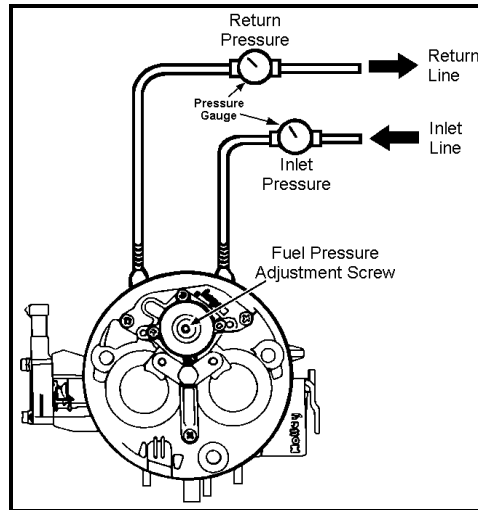

Figure 16

20.2 Testing the Coolant Temperature Sensor

The coolant temperature sensor used with the **PRO-JECTION 2D** system is a single wire sensor. The ECU supplies a fixed voltage to the sensor. The resistance within the sensor varies with temperature and this variation in resistance is used by the ECU to determine the engine's coolant temperature.

1. Drain enough coolant out of the radiator to drop the coolant level below the point in which the engine coolant temperature sensor is installed in the manifold.
2. Remove the sensor from the manifold and allow the sensor to reach room temperature, approximately 70° F.
3. Connect the positive (+) lead of a digital voltmeter set to measure resistance to the metal tab located at the top of the sensor and the negative (-) voltmeter lead to the sensor's body.
4. Measure the resistance. The resistance value of the temperature sensor at room temperature should be approximately 3.8 kΩ.
5. Submerge the body of the coolant temperature sensor in boiling water (212° F) and measure the resistance as described in Step 3. The resistance value of the temperature sensor in boiling water should be approximately 182 kΩ.

NOTE: If the resistance values of your engine coolant temperature sensor do not match these values, the temperature sensor must be replaced.

20.3 Testing the Throttle Position Sensor

A properly adjusted and functioning throttle position sensor is essential to the proper operation of the **PRO-JECTION 2D** system. The TPS is a precision electrical component that acts as a variable resistor. The ECU provides a reference voltage to the TPS. As the resistance varies with the throttle angle, the TPS provides a return signal to the ECU.

1. Disconnect the three-position connector from the TPS and install three jumper wires as shown in Figure 17.
2. Connect the positive (+) lead of a digital voltmeter set to measure DC voltage to the blue wire leading to the TPS and the negative (-) lead of the voltmeter to the black wire leading to the TPS.
3. Turn the ignition key to the "RUN" position. Do not start the engine.
4. Observe the voltmeter and verify that the voltmeter indicates between 0.63 to 0.65 volts with the TPS set at idle.
5. Slowly open the throttle and observe the voltmeter's readout. The voltage should increase smoothly from 0.63 volts at idle to 4.5 to 5.0 volts at wide-open throttle. If the voltmeter readings fluctuate or seem jumpy, the TPS is intermittent and will need to be replaced.
6. Remove the jumper wires and reinstall the 3-position connector.

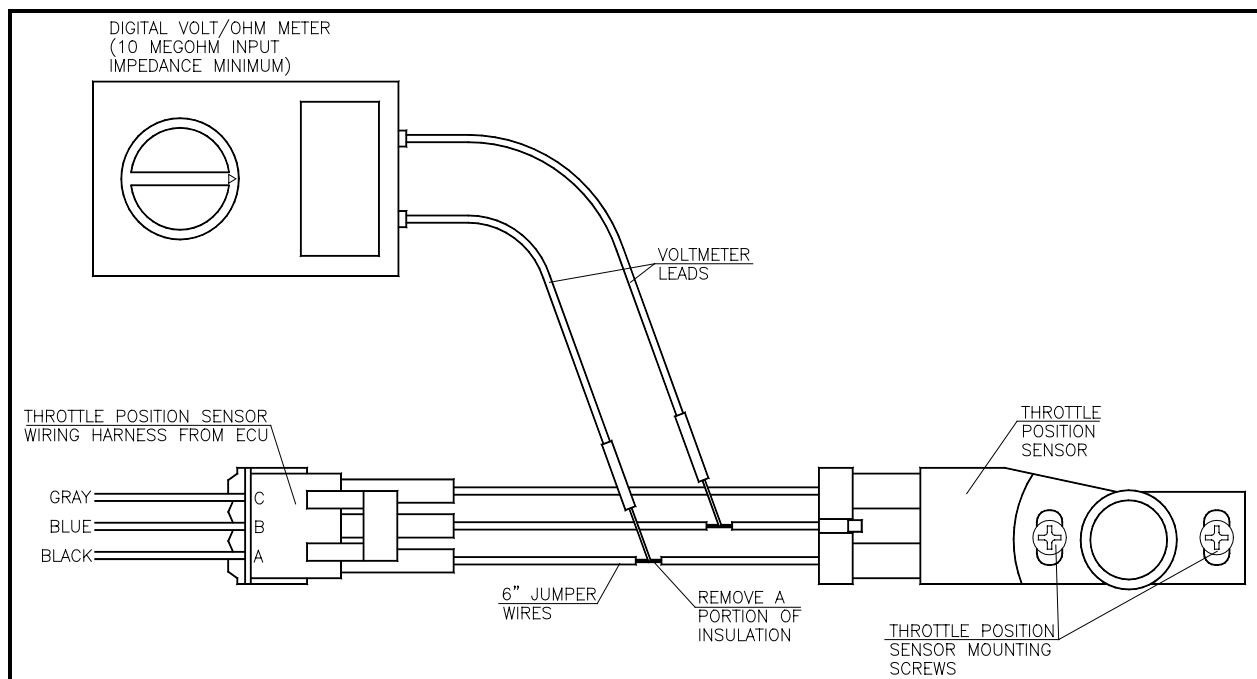

Figure 17

20.4 Testing the Oxygen Sensor (if equipped)

The **PROJECTION D** system oxygen sensor performance can be evaluated. Probe the gray wire from the oxygen sensor connector with the positive (+) lead of a digital voltmeter. With the engine running open loop, the meter reading should be near zero or one volt. During closed-loop operation, the readings should constantly change between zero and one volt. If the reading is always zero volts, be sure +12V and ground are present on the YELLOW and BLACK wires. If so, the sensor is probably bad. If you see a changing voltage, but the readings do not vary far from 0.5 volts, the sensor is lazy and should be replaced.

WARNING! Be sure to use a high-impedance digital voltmeter. An older style analog (dial type readout) has an internal resistance that is too low and will destroy the oxygen sensor if connected to the gray wire.

NOTES:

NOTES:

Copyright © 1999
Printed in U.S.A.

Holley
Performance Products Inc

199R-10028-1
Date: 11-11-99