



## MARINE THROTTLE CABLE BRACKET P/N 717-8 Installation Instructions

### INTRODUCTION:

Congratulations on your purchase of the Holley Marine Throttle Cable Bracket! This Instruction sheet contains all the information needed to install this throttle cable bracket. Please read all the **WARNINGS** and **NOTES**, they contain valuable information that can save you time and money. Holley Performance Products cannot and will not be responsible for any alleged or actual engine or other damage, or other conditions resulting from misapplication of the throttle cable bracket described herein. However, it is our intent to provide the best possible products for our customer; products that perform properly and satisfy your expectations. Should you need information or parts assistance, please contact our Technical Service Department at 1-270-781-9741, Monday through Friday, 7 a.m. to 5 p.m. Central Time. Please have the part number of the product you purchased ready when you call.

**WARNING!** THESE INSTRUCTIONS MUST BE READ AND FULLY UNDERSTOOD BEFORE BEGINNING THE INSTALLATION. FAILURE TO FOLLOW THESE INSTRUCTIONS MAY RESULT IN POOR PERFORMANCE, WATER CRAFT DAMAGE, PERSONAL INJURY, OR DEATH. IF THESE INSTRUCTIONS ARE NOT FULLY UNDERSTOOD, INSTALLATION SHOULD NOT BE ATTEMPTED. PLEASE CONSULT HOLLEY TECH SERVICE OR A QUALIFIED MECHANIC.

**NOTE:** A United States Coast Guard approved fire extinguisher in proper operating condition should be nearby at all times during removal, installation and starting procedures.

**NOTE:** Due to the remote distance between the helm and the engine in most boats, it is **STRONGLY** recommended that the mechanic have an assistant to operate the appropriate helm controls during this installation.

### INSTALLATION OF THROTTLE BRACKET:

1. Disconnect and remove throttle linkage. Save all retaining clips.
2. Remove the two retaining nuts on the throttle linkage side of the carburetor and then the remove the mounting studs.
3. Install the new mounting studs into the manifold.
4. Place the new throttle cable bracket over the mounting studs and hand thread the retaining nuts onto the studs. **DO NOT** tighten down.
5. The throttle cable holder is adjustable and should be set to the correct position for your application at this time.
6. Reposition the bracket and torque the retaining nuts to the proper specs, 5-7 ft./lbs.
7. Reconnect the throttle cable and return spring. Secure cable with the latch on throttle bracket.

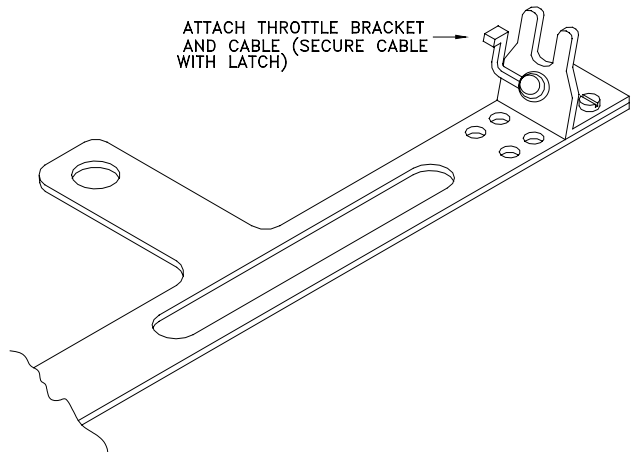

**WARNING!** CHECK THE ASSEMBLED THROTTLE LINKAGE FOR STICKING AND/OR BINDING TO BE SURE THERE IS NO INTERFERENCE WHEN THE THROTTLE LEVER IS OPERATED BETWEEN THE IDLE AND THE FUEL WIDE OPEN THROTTLE POSITIONS. STICKING OR BINDING THROTTLE LINKAGE CAN RESULT IN PERSONAL INJURY AND PROPERTY OR ENGINE DAMAGE DUE TO UNCONTROLLED ENGINE SPEED.

**WARNING!** CHECK FOR STICKING BY HAVING THE ASSISTANT GO THE HELM. OPEN AND CLOSE THE THROTTLE CONTROLS WHILE THE EXPERIENCED MECHANIC WATCHES THE OPERATION OF THE CARBURETOR TO DETECT ANY MALFUNCTION.