

The following parts are included in this package: *2260020*

Qty.	Part No.	Description
1	117 9061	Bracket
1	226 0003	Solenoid
2	970 80969	1/4"-20 x 1" Hex Head Bolt
2	970 00910	1/4"-20 Hex Nut
2	970 00818	1/4" I.D. Flat Washer
4	228 8540	Spacer
1	970 01847	Inline Fuseholder w/4 Amp Fuse
4	970 07069	Butt Splice Connectors 14-16 Gauge

HOW TO INSTALL YOUR HURST SOLENOID SHIFTING KIT

This electric solenoid shifting kit is designed to automatically complete the 1st to 2nd gear change on all Hurst Quarter Stick shifters with forward shift patterns. It must be used with a 12-volt automotive electrical system. This kit may also be adapted to the B&M Pro Stick Shifter and Hurst Quarter Stick 2 (rear exit cable model) with minor bracket modification.

WORK SAFELY! Place vehicle on a solid level surface. Place wheel blocks both in front of and behind two of the wheels to prevent movement in either direction.

1. Disconnect negative (-) battery cable.
2. Remove fasteners from shifter and raise shifter up from floor (cable does not need to be disconnected).
3. Using existing mounting holes, install the solenoid bracket under the shifter aligning the mounting holes, and remount unit into vehicle using existing fasteners. Tighten fasteners securely.
4. Attach the electric solenoid to the mounting bracket using the four spacers and fasten with two 1/4"-20 hex head bolts, nuts and 1/4" flat washers. Tighten securely. (Refer to Figure A.)
5. Place shifter stick into 2nd gear position. While holding the solenoid plunger, turn adjusting nut on the backside of the solenoid to allow 1/16" clearance between plunger and shifter stick.

Wiring

1. All wiring used should be a minimum of 18 gauge automotive grade.
2. Either black wire from the solenoid can be used for 12-volt source and ground.
3. If you are using an RPM-activated switch to control the solenoid, refer to the manufacturer's instructions for proper wiring connections.
4. If you are using a manually-activated switch, it must be a normally "closed" switch that is momentarily "open" when activated. Refer to the wiring diagram (Figure B) in this instruction sheet.

IMPORTANT: The solenoid must be energized for the shifter to remain in 1st gear.

Solenoid Operation

NOTE: Be sure that negative (-) battery cable has been reconnected.

1. Pull the shifter stick back into 1st gear position pushing the plunger into the solenoid. If you are using an RPM-activated switch, follow the manufacturer's instruction to activate the solenoid.
2. If you are using a manual-activated switch, at the desired RPM or speed, release or "open" the switch to de-energize the solenoid causing the spring to push the plunger forward. This action will shift the transmission from 1st to 2nd gear.

Solenoid Specifications

12-Volt With Maximum Rated Amp Draw of 3-Amps.

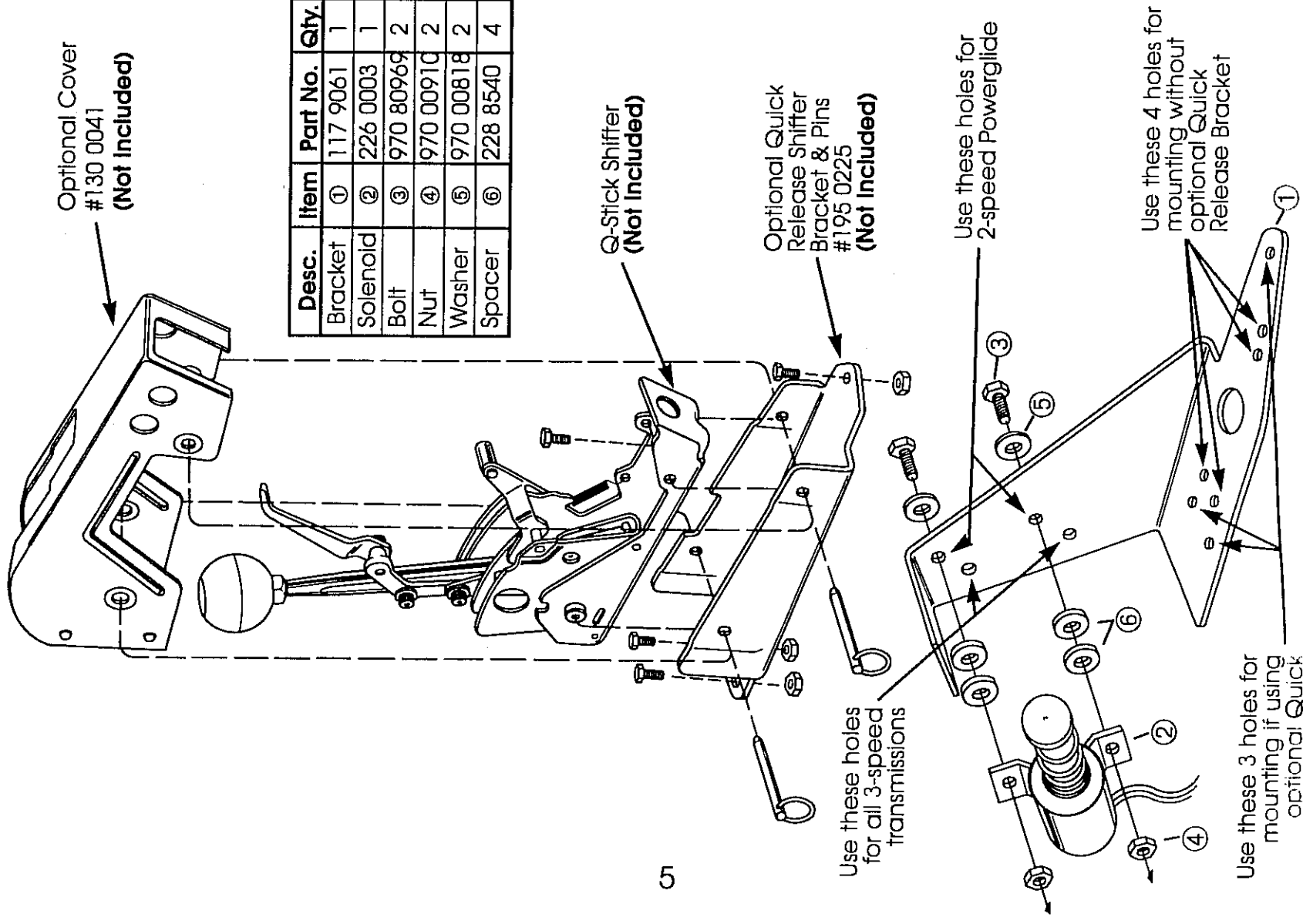

Optional Cover
#130 0041
(Not Included)

Desc.	Item	Part No.	Qty.
Bracket	①	117 9061	1
Solenoid	②	226 0003	1
Bolt	③	970 80969	2
Nut	④	970 00910	2
Washer	⑤	970 00818	2
Spacer	⑥	228 8540	4

Q-Stick Shifter
(Not Included)

Optional Quick
Release Shifter
Bracket & Pins
#195 0225
(Not Included)

Use these holes
for all 3-speed
transmissions

Use these holes for
2-speed Powerglide

Use these 4 holes for
mounting without
optional Quick
Release Bracket

Use these 3 holes for
mounting if using
optional Quick
Release Bracket

Figure A

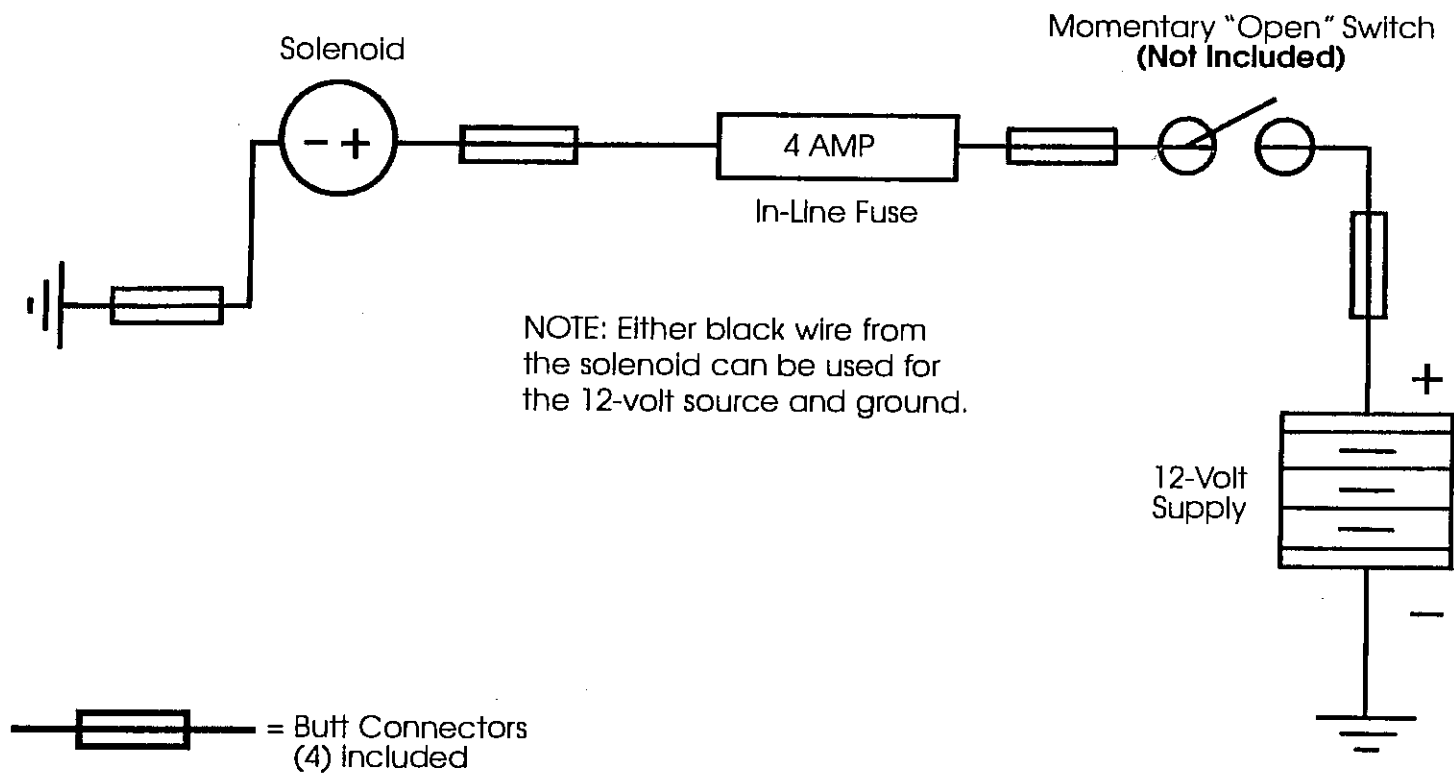

Figure B