

UNIVERSAL "PLUS 4" MUD GUARD INSTALLATION INSTRUCTIONS

Please read instructions thoroughly before installation.

Possible Tools Required:

- 1/8" & 1/4" drill bit / Drill
- Center punch / Hammer
- Short Phillips screwdriver
- Marking utensil (fine tip marker, grease pencil, etc.)

Package Contents

- Driver & passenger side mud guard
- 1" #10 screws (qty. 8)
- U-Clips (qty. 8)
- Plastic fasteners (qty. 2)
- Instruction sheet

NOTE: It may be necessary to remove the wheels depending on the tools being used for installation.

1. Clean and degrease the mud guard location areas on the fenders before installation. Determine if existing factory fasteners and/or holes in the fenders can be used to mount the mud guards to the fenders. You may still need to drill some holes to completely install your mud guards, but existing factory fasteners and holes should be used wherever possible.
2. **If existing factory fastener(s) can be used to attach the mud guards:** Remove fastener(s), align mud guard, mark factory hole location(s) on mud guard, drill 1/4" hole thru mud guard and attach mud guard to fenders with factory fasteners.
3. **If an existing fender hole(s) can be used to attach the mud guards:** Align mud guard, mark factory hole location(s) on mud guard, and drill 1/4" hole thru mud guard. Slide U-Clip over or place behind fender hole and attach mud guard with #10 screw thru mud guard and fender and into U-Clip. Make sure mud guard is level with ground before tightening fasteners. NOTE: A plastic fastener can be substituted for the #10 screw and U-Clip depending on hole size.
4. **If some or all holes need to be drilled into fender:** (Figure 1) Align mud guard, mark and drill 1/8" hole (approx 1/4" from top of mud guard where possible) and attach mud guard to fender with a #10 screw. Make sure mud guard is level to ground before tightening. With mud guard in place, mark and drill remaining holes and fasten with #10 screws. Space mounting holes evenly to insure maximum support of mud guard.

TYPICAL INSTALLATION: HOWEVER
IT MAY BE NECESSARY TO USE A
COMBINATION OF STEPS 2 THRU 4
IN ORDER TO COMPLETE INSTALLTION

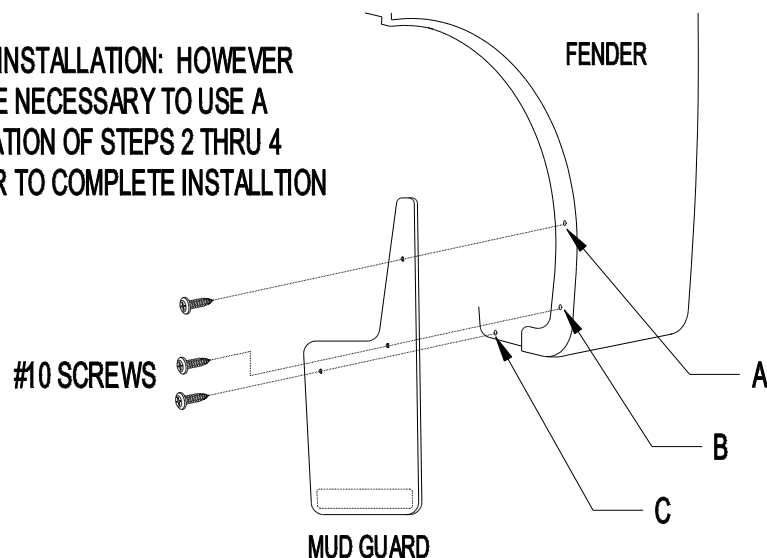

Figure 1