



FORD F-250/350 w/o FENDER FLARES REAR MUD GUARD INSTALLATION INSTRUCTIONS

Please read instructions thoroughly before installation.

Tools Required

- Short #2 Phillips screwdriver

Package Contents

- Driver & passenger side rear mud guard
- #10 SEM screw (qty. 8)
- U-Clip (qty. 8)
- Aluminum L-Bracket (Qty. 2)
- Instruction Sheet

NOTE: It may be necessary to remove the rear wheels for mud guard installation.

1. Clean the mud guard location area on the fender before installation.
2. Install u-clips at locations A and B (Figure 1 and 3).
3. Attach mud guard with #10 SEM screws at locations A and B, check fit and make sure the mud guard is parallel to the ground before tightening.
4. Attach the supplied L-bracket to the vehicle at location E with a #10 SEM screw through the hole in the bottom-side of the fender, through the L-bracket and into a u-clip (see figure 2).
5. Install #10 SEM screw at location D through mudguard and L-bracket and into a u-clip on the back side of the L-bracket (U-clip does not clip over the L-bracket) see figure 2.

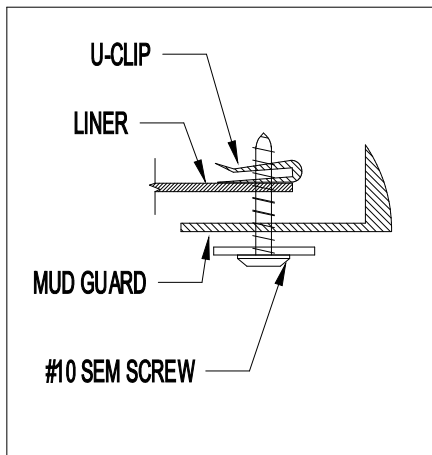

Figure 2

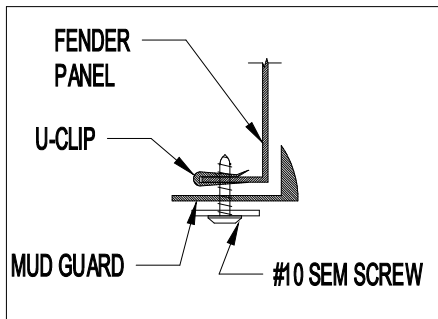

Figure 3

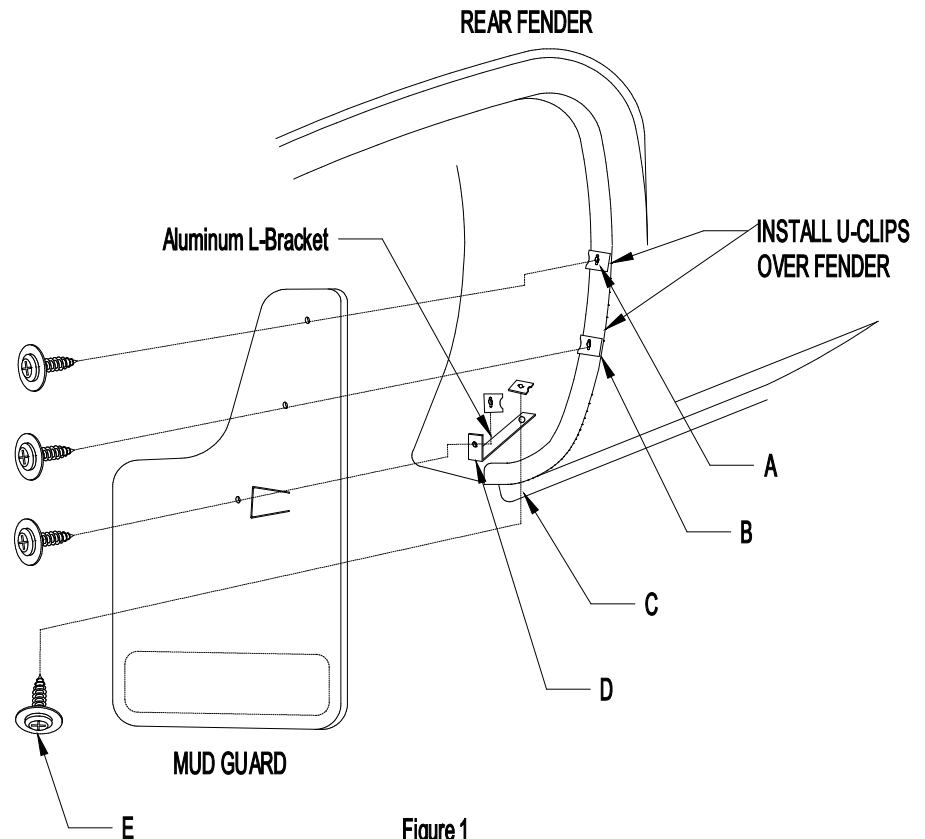

Figure 1