



# FORD SUPER DUTY DUALY REAR FLAT MUD GUARD

## INSTALLATION INSTRUCTIONS

*Please read instructions thoroughly before installation.*

### Tools Required

- Short Phillips screwdriver
- Cutting tool - for removal of existing plastic fasteners

### Package Contents

- Driver & passenger side rear mud guard
- #10 SEM screw (qty. 10)
- U-clip (qty. 10)
- Instruction sheet

**NOTE:** It may be necessary to remove the wheels depending on the tools being used for installation.

1. Clean and degrease the mud guard location area on the fender before installation.
2. Remove existing plastic fasteners from locations A, C, D, and E by using a flat blade screw driver to remove the center of the plastic rivets and pulling the remaining piece from the fender tab hole (Figure 1).
3. Remove the existing screw and washer from location B.
4. Pull back fender liner to expose fender tabs and install a U-clip at locations A, B, C, D, and E.
5. Place mud guard between fender and fender liner and install a #10 SEM screws through fender liner, mud guard, U-clip and fender tab at locations A, B, C, D, and E.

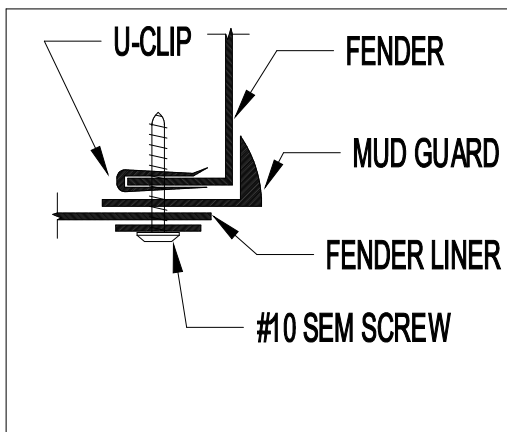

Figure 2

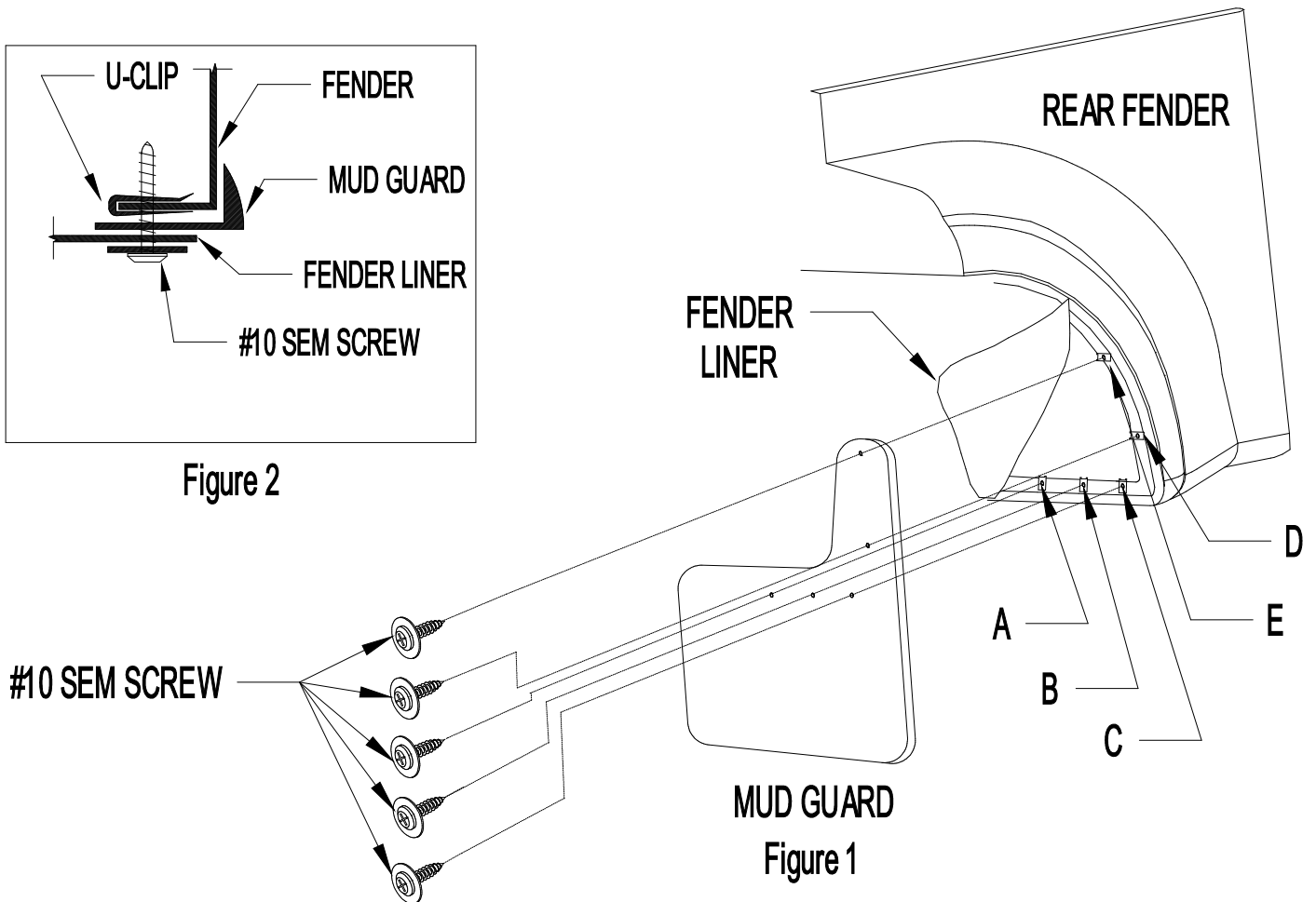

Figure 1