



# DODGE RAM WITHOUT FENDER FLARES FRONT MUD GUARD INSTALLATION INSTRUCTIONS

PART NO: 5617

*Please read instructions thoroughly before installation.*

## Tools Required

- Short Phillips screwdriver
- Center punch
- Drill / 1/8" drill bit

## Package Contents

- Driver & passenger side front mud guards
- #10 Phillips Head SEM Screw (qty. 4)
- Medium U-Clip (qty. 4)
- Paint Protection Film (1 set)
- Instruction sheet

**IMPORTANT! PLEASE READ BEFORE ANY INSTALLATION.** DURING THE 2011 MODEL YEAR, DODGE MANUFACTURED RAM TRUCKS WITH 2 DIFFERENT LOWER FENDER "ROCK GUARDS". PLEASE REVIEW THE IMAGES BELOW AND IDENTIFY YOUR SPECIFIC "ROCK GUARD" CONFIGURATION AND FOLLOW THE CORRESPONDING INSTALLATION INSTRUCTIONS. ALL 2012 AND NEWER VEHICLES HAVE THE LARGE ROCK GUARD WHICH WILL HAVE TO BE REMOVED FOR MUD GUARD INSTALLATION.

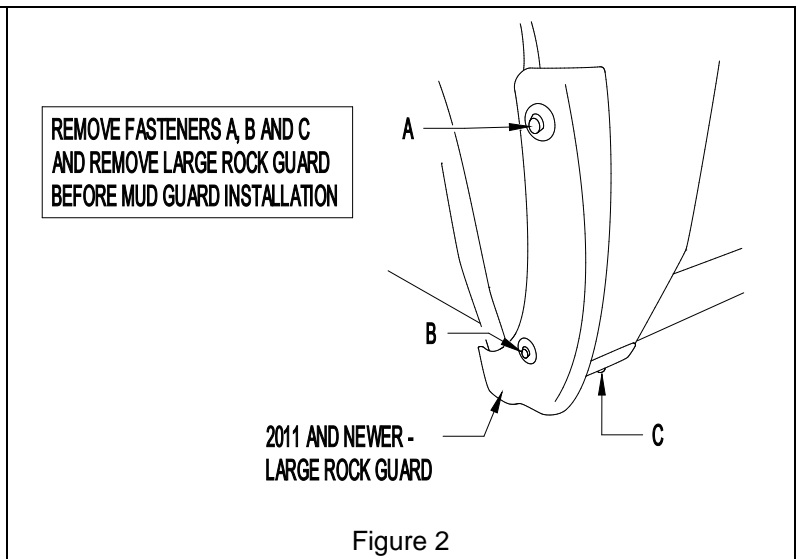
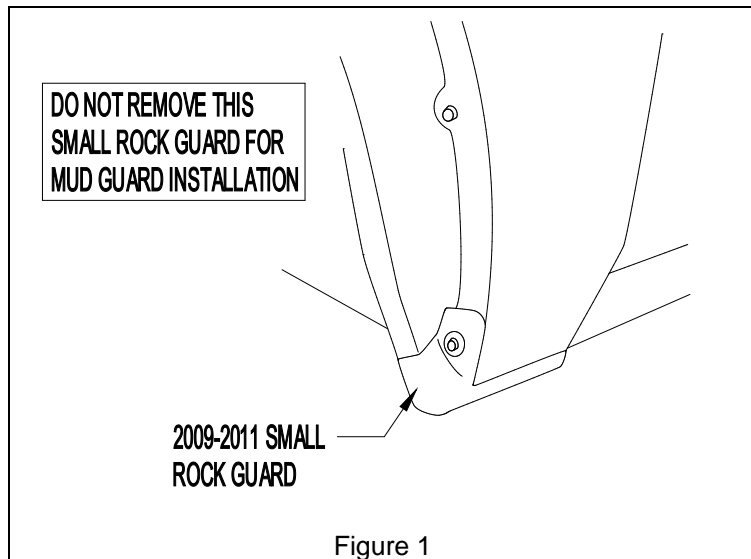

## VEHICLE PREPARATION

**FIGURE 1:** If you have the "small rock guard" as shown in Figure 1., simply leave the rock guard in place. Next, follow the paint protection film instructions and then the mud guard installation instructions.

**FIGURE 2:** If you have a 2011 or newer Dodge Ram with the "large rock guard" as shown in Figure 2, remove fasteners A, B, and C, and remove the "large rock guard" (Figure 3). After removal of the "large rock guard" reinstall fastener C. Then proceed with the paint protection film instructions followed by the mud guard installation instructions.

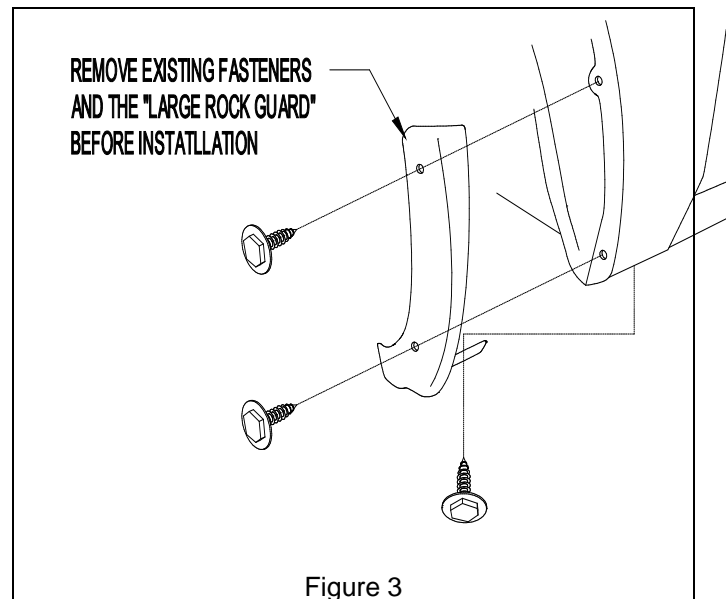

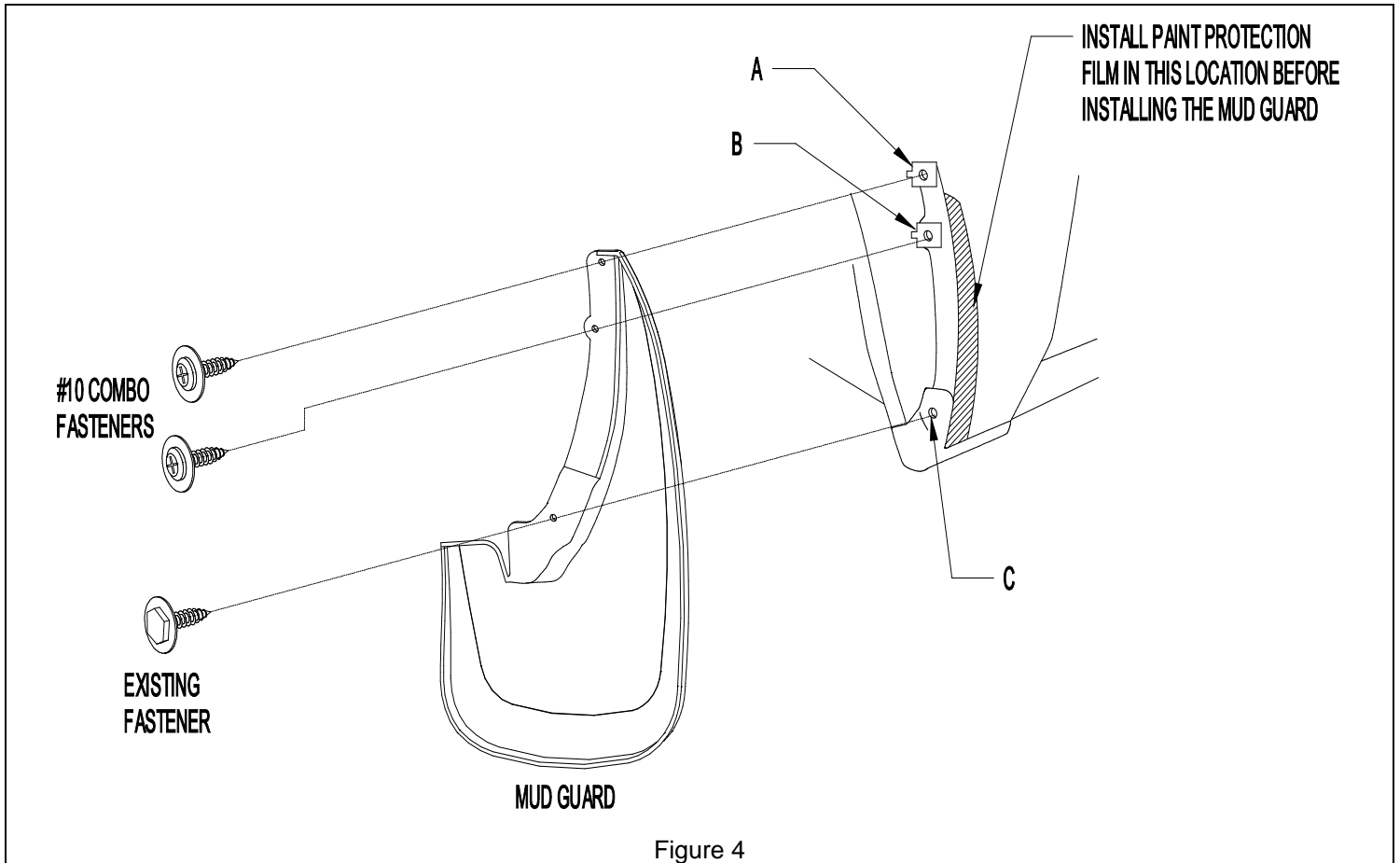

SMALL ROCK GUARD FILM AND MUD GUARD INSTALLATION

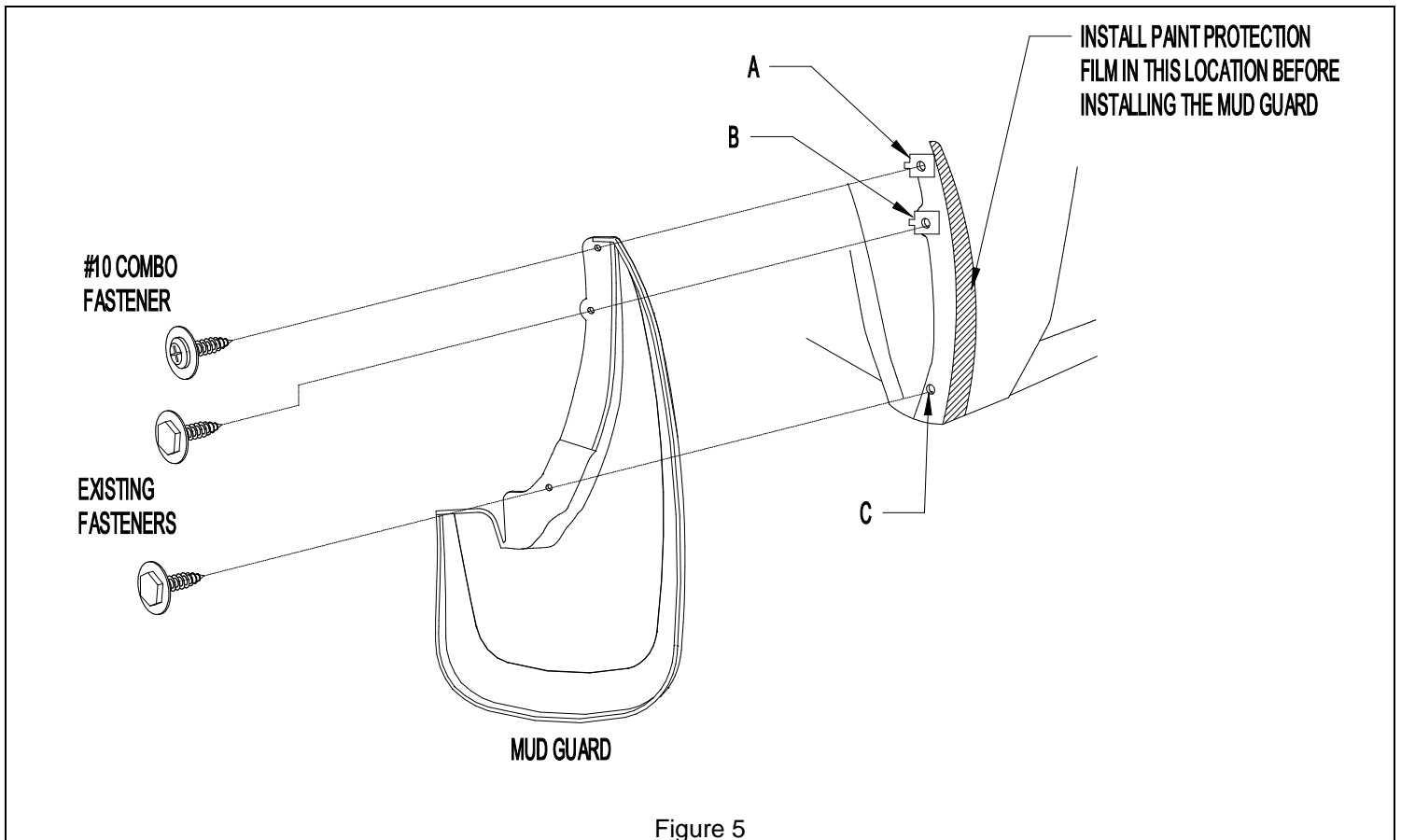

LARGE ROCK GUARD FILM AND INSTALLATION INSTRUCTION

## 2013 CHROME TUBULAR STEP ADJUSTMENT

---

On some 2013 Ram models the optional "Chrome Tubular steps have to be adjusted to allow clearance for Husky Mudguards

**NOTE: If your Chrome Tubular Step appears as in Figure 6 then proceed with Mudguard Install.**



Figure 6

**NOTE: If your Chrome Tubular Step appears as in Figure 7 than adjustment is needed.(See instructions below)**



Figure 7

1. Remove the 4 bolts on the bottom of the tube step at each bracket (8 screws total per each side) Figure 8.



Figure 8

2. Remove the tube step from the brackets. Figure 9



Figure 9

3. Swap sides with the tube steps (Drivers side to the Passengers side, Passengers side to the Drivers side)

4. Reinstall 4 bolts on the bottom of the tube step at each bracket. (8 screws total per side) Figure 8
5. Proceed with mudguard install

## **PAINT PROTECTION FILM INSTALLATION**

---

The Paint Protection Film is a precut template of film used to protect the mud guard mounting surfaces of your fenders against wear. The templates (left and right side) can be removed from the backing liner by folding the liner at the center cut of the template, separating the film sides and peeling the film templates from the backing liner.

**NOTE: Install the paint protection film supplied in your installation kit before installing the mud guards.**

1. If you have the "large rock" shown in Figure 2, remove the large rock guard before you install the paint protection film as shown in Figure 5. If you have the small rock guard shown in Figure 1, leave the small rock guard in place and proceed with the paint protection film installation as shown in Figure 4.
2. Position mud guard on fender to indicate placement location of paint protection film.
3. Clean the placement area of fender with a clean cotton cloth and a petroleum distillate based cleaner such as DuPont Prep-Sol Brand Solvent Cleaner or 3M Brand Adhesive Cleaner and dry.
4. Mix a wetting solution of 1 pint of water with 4 drops of liquid dishwashing detergent.
5. Mark correct position of film by placing mud guard against fender.
6. Remove protection film from liner and flood adhesive side of film with wetting solution (use a spray bottle or sponge).
7. Thoroughly wet film placement location of fender with wetting solution.
8. Position the adhesive side of film on fender and flood with wetting solution.
9. Check location of film with mud guard and reposition as necessary.
10. Using a sponge, squeegee any air bubbles and wrinkles from film.
11. Allow film to dry before installing mud guard.

## **MUD GUARD INSTALLATION**

---

**NOTE: Turn wheels all the way left or right for easier installation. It may be necessary to remove the wheels before mud guard installation.**

1. Remove the existing fastener from location C or from locations A, B and C if you have the "large rock guard". Replace fastener C after removal of the "large rock guard" if applicable. Once again, use Figure 4 if you have the "small rock guard" in Figure 1 or use Figure 5 if you have the "large rock guard" in Figure 2.
2. If you have a factory fastener at location B remove it as well (Figure 5).
3. Attach the mud guard at location C (and B if applicable) with the existing fastener(s). Check the mud guard fit and appearance before tightening.
4. If there is not an existing factory fastener at location B, install a Medium U-Clip over the sheet metal fender and align with the existing hole at location B. Install a #10 SEM Screw at location B (Figure 4).
5. Using the mud guard as a template, mark and drill 1/8" hole at location A (Figure 4 or 5).
6. Install a Medium U-Clip at location A and install a #10 SEM Screw at location A.

If you are interested in painting your mud guards, its best to contact your local body shop or you can call us at 1-800-344-8759. Always test fit the mud guard to ensure you have the correct part no. and application before painting.