

JKS[®]

Installation Instructions



Product: **Adjustable Cross-Over Shock Mount**

Part Number: **PN OGS999**

Application: **Cherokee XJ, 1984-01**

Welcome

CONGRATULATIONS on purchasing a new Adjustable Cross-Over Shock Mount from JKS Manufacturing. We are committed to providing you with the best products available and your satisfaction is our first priority.

PLEASE READ these instructions carefully, as they contain important installation information.

Important

EXHAUST MODIFICATIONS ARE REQUIRED in order to install this product.

NEW SHOCK ABSORBERS ARE REQUIRED unless optional Rear Axle Shock Mounts PN OGS922 are installed at the same time.

Parts

	DESCRIPTION	QTY
A	Cross-Over Shock Mount	1
B	Hex Shock Mounting Studs	2
C	5/8" Locking Nuts	2
D	5/8" Flat Washers	2
E	7/16" Flat Washers	2
F	7/16" Locking Nuts	2
G	5/16" x 1-1/4" Bolts	4
H	M8 x 30mm Bolts	4
I	5/16" Flat Washers	4
J	5/16" Split Washers	4

Tools Required

- Metric/Standard Socket Wrench Set
- Torque Wrench
- Hammer & Punch *
- Die Grinder with Sanding/Grinding Wheel (or similar tool for cleaning chassis and axle) *
- Anti-Seize Lubricant
- Cutting Wheel or Cutting Torch (for removing OE rear shock mounts from axle) *
- Welding Equipment *
- Satin Black Spray Paint *
- Wheel Bearing Grease
- Factory Service Manual (recommended)

* Asterisk denotes tools that are not required for some applications. Thoroughly read instructions first to determine which tools will be required for your application.

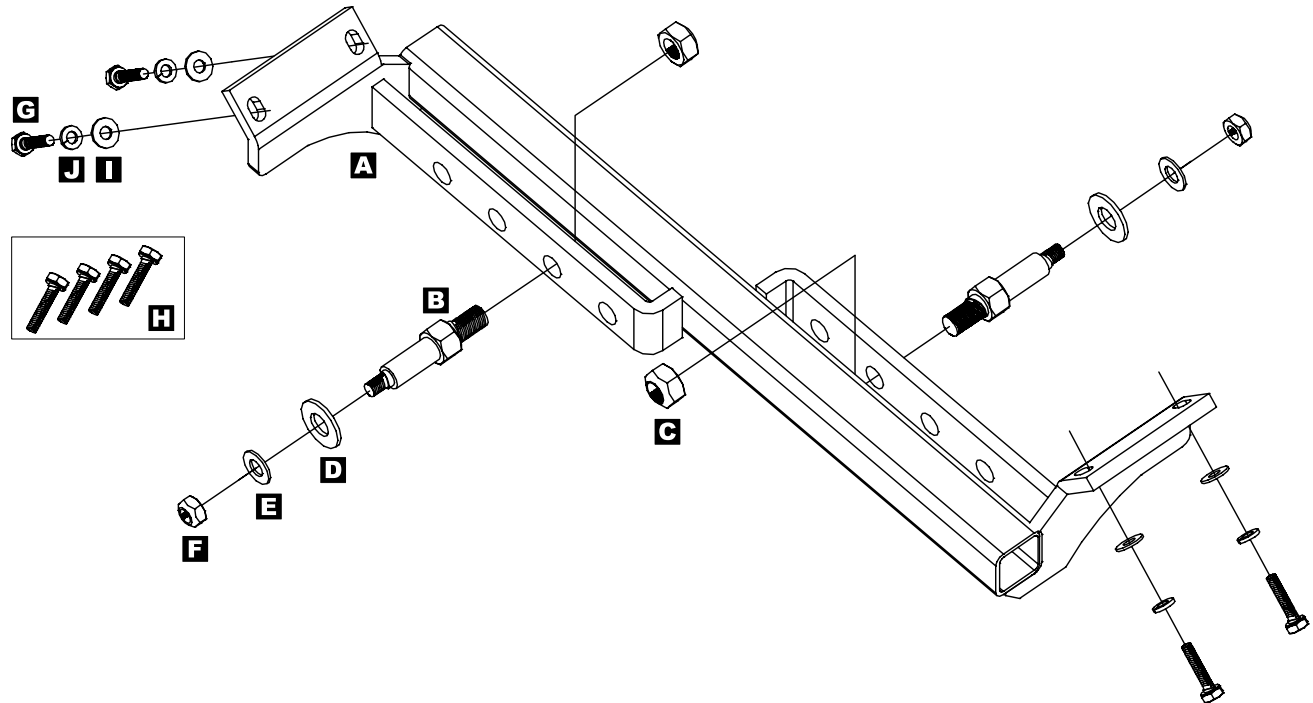

Installation

❑ 1. REMOVE SHOCK ABSORBERS

- Completely remove the rear shock absorbers per the factory service manual instructions for your vehicle.
- If shock absorbers will be re-installed, remove the bar pin from the upper shock bushings. **HINT:** A hammer and punch may be useful for removing bar pin.
- Inspect upper shock absorber mounting surface for any dirt or debris. If necessary, thoroughly clean mounting surface until completely free of debris. **HINT:** A sanding or grinding wheel is useful for removing any stubborn material.

❑ 2. REMOVE VEHICLE EXHAUST

IMPORTANT: It will be necessary to remove and modify the vehicle's exhaust system in order to install the Cross-Over Shock Mount.

- Inspect vehicle exhaust and locate the point at which the tail pipe can be disconnected from the rest of the exhaust system. **HINT:** The factory exhaust can be disconnected between the catalytic converter and muffler by removing the U-bolt clamp. Aftermarket exhaust systems may provide a more convenient disconnect point further down the tail pipe.
- Disconnect the tail pipe from the exhaust system per the factory service manual instructions for your vehicle.

❑ 3. INSTALL CROSS-OVER SHOCK MOUNT TO VEHICLE

- Determine whether rear upper shock mounting holes in chassis require metric or standard bolts. **HINT:** Cross-Over Shock Mount will be installed using either metric M8 x 30mm (H) or standard 5/16" x 1-1/4" (G) mounting bolts, depending on the application. Both types of bolts are supplied, but only one will thread easily into the original mounting holes.

IMPORTANT: Trial fit metric and standard bolts in mounting holes first to avoid cross-threading during installation.

- Place a 5/16" Split Washer (J) and 5/16" Flat Washer (I) on the appropriate metric (H) or standard (G) mounting bolts. Apply anti-seize lubricant to bolt threads.
- Position Cross-Over Shock Mount against the chassis. Align holes in mounting flange with original upper shock mounting holes.
- Insert the appropriate bolt assembly through each hole in mounting flange and loosely thread into mounting hole to hold the Cross-Over Shock Mount in place.

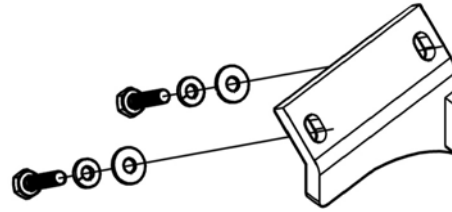

- With all four mounting bolts loosely installed, make sure Cross-Over Shock Mount rests completely flat against chassis and tighten each bolt to 25-35 ft-lbs using a torque wrench.

❑ 4. INSTALL REAR AXLE SHOCK MOUNTS (OPTIONAL)

Refer to the following instructions only if you will be installing optional Rear Axle Shock Mounts PN OGS922 (**SOLD SEPARATELY**) in combination with the Cross-Over Shock Mount. **HINT:** The benefit of installing Rear Axle Shock Mounts at this time is the ability to re-install your existing shock absorbers. If not installing Rear Axle Shock Mounts, it will be necessary to install new shock absorbers of the appropriate length as determined by vehicle's lift height and shock mounting configuration.

- Remove the factory rear shock mounts from the axle housing. **HINT:** A grinding wheel or cutting torch may be useful for removing factory shock mounts, although extreme care must be used to ensure axle housing is not damaged in process.
- Grind or sand away any remaining material, paint or debris from axle housing to prepare surface for Rear Axle Shock Mounts. Surface must be completely free of any contaminants.
- Secure stud to weld-on bracket using a 5/8" Locking Nut. Tighten nut to 65 ft-lbs using a torque wrench.

- Position Rear Axle Shock Mounts on the axle housing between each pair of leaf spring U-bolts. New shock mounts should be oriented as indicated below. **HINT:** Hex Stud must be parallel with level ground.

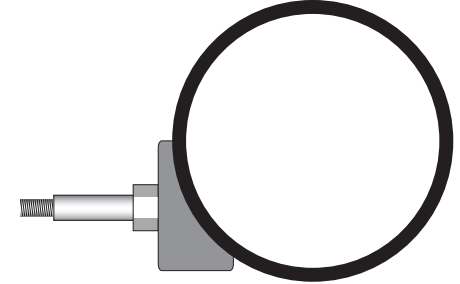

- Carefully weld the Rear Axle Shock Mount to the axle housing, making sure the Hex Stud remains parallel with ground.

IMPORTANT: Avoid overheating axle housing by allowing the surface to cool off regularly.

- Once all welding is complete, spray paint weld-on shock mount and any bare metal on axle to prevent corrosion. All exposed metal must be completely covered.
- Apply a thin coating of wheel bearing grease to smooth surface of Hex Shock Stud.
- Use the remaining 5/8" and 7/16" Flat Washers to "sandwich" the shock absorber bushing, and secure the shock to the Hex Stud with the 7/16" Locking Nut. Tighten nut until shock bushing begins to bulge, but do not overtighten.

5. INSTALL SHOCK ABSORBERS

- Secure stud to Cross-Over Shock Mount using a 5/8" Locking Nut (C). Tighten the nut to 65 ft-lbs using a torque wrench.

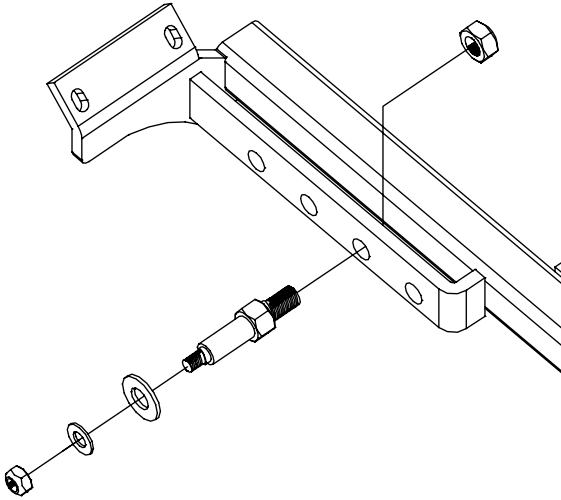

- Apply a thin coating of wheel bearing grease to smooth surface of Hex Shock Stud (B).
- Slide a 5/8" Flat Washer (D) onto stud, followed by the upper end of shock absorber.
- Secure upper end of shock absorber to Hex Shock Stud (B) with the remaining 7/16" Flat Washer (E) and 7/16" Locking Nut (F). Tighten nut until shock bushing begins to bulge, but do not overtighten.
- Secure lower end of shock absorber to factory shock mount on axle, or optional Rear Axle Shock Mounts PN OGS922 if installed.

6. MODIFY VEHICLE EXHAUST

Due to the position of the Cross-Over Shock Mount, the existing tail pipe section can not be re-installed without modifications.

IMPORTANT: Modifications to exhaust system should be performed by a professional.

- To modify the exhaust system, have a new tail pipe formed to route between the Cross-Over Shock Mount and vehicle chassis. **HINT:** A heat shield can be installed around tail pipe to minimize transfer of exhaust heat to surrounding surfaces.
- Cut existing tail pipe behind the catalytic converter and connect to the new tail pipe using an appropriate exhaust joint.
- Replace any exhaust gaskets and install the modified tail pipe on vehicle. Check for leaks.

© 2009 JKS Manufacturing, Inc & Aftermarketing, LLC
Revision Date 9/12/2009