

JKS[®]

Installation Instructions

Product: Adjustable Trackbar

Part Number: PN OGS155

Welcome

CONGRATULATIONS on purchasing a new Adjustable Trackbar from JKS Manufacturing. We are committed to providing you with the best products available and your satisfaction is our first priority.

PLEASE READ these Installation Instructions carefully, and save them for future reference, as they contain important installation and maintenance information.

Tools Required

- Metric/Standard Socket Wrench Set
- Torque Wrench
- Tape Measure
- 1-1/2" Open-End Wrench
- Heavy Duty Ratchet Strap *
- Anti-Seize Lubricant
- Hydraulic Press *
- Wheel Bearing Grease

* Asterisk denotes tools that are not required for some applications. Thoroughly read instructions first to determine which tools will be required for your application.

Parts

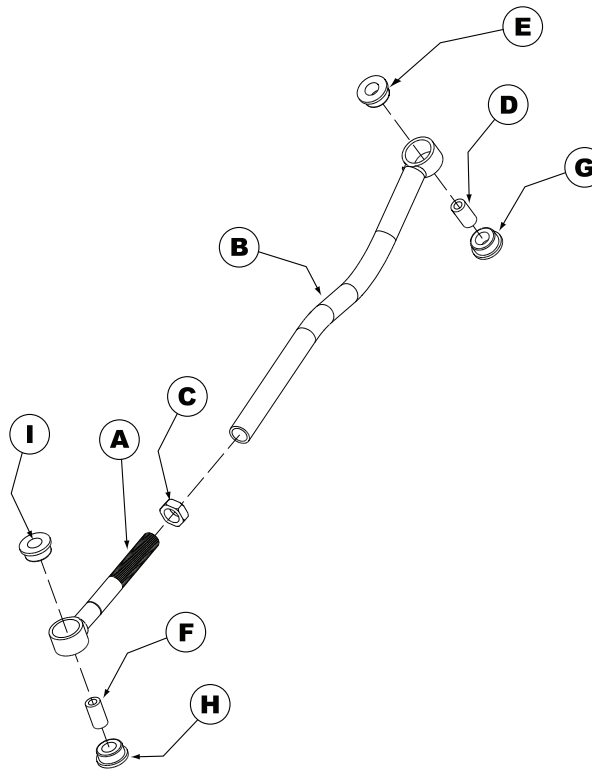

A	Male Threaded (Axle) End
B	Female Threaded (Chassis) End
C	1" NF Jam Nut
D	Sleeve
E	Polyurethane Bushing
F	Sleeve
G	Polyurethane Bushing
H	Polyurethane Bushing
I	Polyurethane Bushing

Important

NOT COMPATIBLE WITH right hand drive vehicles.

CHECK TORQUE SPECIFICATIONS regularly.

Installation

- ❑ 1. **REMOVE ORIGINAL EQUIPMENT (OE) REAR TRACK BAR**
 - Remove rear track bar and mounting hardware per factory service manual instructions for your vehicle. Retain original mounting hardware as it is required for Adjustable Trackbar installation. **HINT:** The original trackbar bushings may be retained as spares for your Adjustable Trackbar if replacement parts are ever needed. See Maintenance section for details.
- ❑ 2. **LUBRICATE BUSHINGS AT BOTH ENDS OF ADJUSTABLE TRACKBAR**
 - Locate bag of parts containing Polyurethane Bushings (E, G, H, & I) and Sleeves (D & F).
 - Liberally apply wheel bearing grease to surface of bushings.
 - Assemble Polyurethane Bushings and Sleeves at each end of trackbar as indicated in the parts diagram to the left.
- ❑ 3. **MOUNT ADJUSTABLE TRACKBAR TO CHASSIS BRACKET**
 - Mount Chassis End (B) of Adjustable Trackbar to chassis rail bracket and temporarily secure with original mounting hardware. Apply anti-seize lubricant to bolt threads. **HINT:** When installed correctly, the curve in Adjustable Trackbar should point toward front of vehicle.

4. CENTER REAR AXLE HOUSING

The rear axle housing must be in perfect lateral alignment with vehicle chassis before Adjustable Trackbar installation can be completed.

- Before you center the axle housing, make sure the vehicle is at normal ride height, on level ground, with the suspension supporting the full vehicle weight.
- Determine if axle housing is centered by measuring the distance between the tire and chassis, using exact same points on each side of vehicle to ensure accuracy.



HINT: For example, measure from the edge of a tire tread lug to the outboard side of chassis, then repeat the measurement on other side of vehicle using exact same points.

- If the two measurements are equal, the axle is centered. If measurements vary, divide the difference in half to determine the amount of adjustment required. **HINT:** If axle housing is not centered, the chassis can be laterally shifted using either of the following methods.

Ratchet Strap (preferred)

- Attach a heavy duty ratchet strap to the chassis on one side of the vehicle, and to the axle housing on the other side.
- Slowly tighten the strap in small increments to pull the chassis in alignment with the axle. Take measurements after each adjustment until centered.

Pushing Vehicle Body

Although this method will laterally shift position of chassis relative to axle housing, it does not enable the position to be easily stabilized while measurements are taken.

- With the vehicle safely on the ground, have a partner gently push on the vehicle body above the rear wheels.

5. SET ADJUSTABLE TRACKBAR LENGTH AND MOUNT TO AXLE

IMPORTANT: Length of Adjustable Trackbar must be set with axle housing perfectly centered and vehicle at normal ride height.

- With axle housing centered beneath the chassis, adjust length of Adjustable Trackbar by rotating Axle End (A) until the Bushing Sleeve (F) aligns with mounting holes on axle bracket.

IMPORTANT: If Bushing Sleeve at Axle End is not parallel with axle bracket mounting holes, first confirm that factory bend in Axle End of trackbar is pointing towards the front of vehicle. If Bushing Sleeve is still out of alignment, it may be necessary to slightly bend Axle End of trackbar using a hydraulic press. Variations in the axle bracket position are typically the result of modifications to related suspension parts.

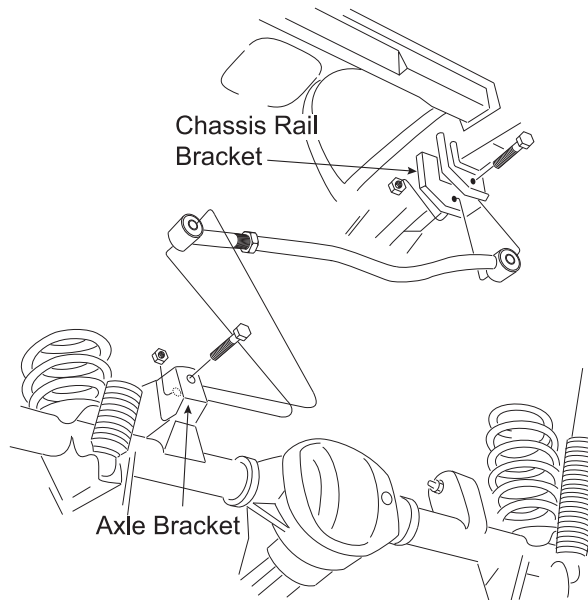

HINT: The factory rear trackbar bracket on axle utilizes a "pocket" design that requires the Adjustable Trackbar be removed from the chassis bracket before Axle End (A) can be inserted. This may not be necessary if an aftermarket extension bracket has been installed on the factory axle bracket.

- Apply anti-seize lubricant to original mounting bolt threads and adjustment threads of trackbar.
- Install Axle End (A) of Adjustable Trackbar to the axle bracket by securing with the original mounting hardware.
- Take measurements again to ensure axle housing is perfectly centered and make any final adjustments if necessary.
- Once all adjustments are complete, fully tighten the Jam Nut (C) to prevent Adjustable Trackbar length from changing. **HINT:** It may be easier to tighten Jam Nut with the Adjustable Trackbar removed from the vehicle.
- Tighten mounting bolts on axle bracket and chassis rail bracket to 50 ft-lb. using a torque wrench.

Maintenance

Check torque specifications regularly.

Regular cleaning with pressurized water is recommended to maximize reliability.

The original equipment trackbar uses the same bushing size as the JKS Adjustable Trackbar. Upon removal of the original trackbar, the OE bushings should be retained if in good condition. In the unlikely event that the Adjustable Trackbar bushings wear out, the OE trackbar bushings may be used as replacements.

© 2011 JKS Manufacturing, Inc & Aftermarketing, LLC
Revision Date 7/20/2011