



# Installation Instructions



Product: **Adjustable Trackbar**

Part Number: **PN OGS159**

Application: **Jeep Wrangler JK, 2007+ (rear)**

## Welcome

CONGRATULATIONS on purchasing a new Adjustable Trackbar from JKS Manufacturing. We are committed to providing you with the best products available and your satisfaction is our first priority.

PLEASE READ these Installation Instructions carefully, and save them for future reference, as they contain important installation and maintenance information.

## Important

**NOT COMPATIBLE WITH** right hand drive vehicles.

**CHECK TORQUE SPECIFICATIONS** regularly.

## Tools Required

- Hydraulic Floor Jack & Jack Stands
- Metric/Standard Socket Wrench Set
- Torque Wrench
- 1-1/2" Open-End Wrench
- Tape Measure
- Heavy Duty Ratchet Strap \*
- Anti-Seize Lubricant
- Factory Service Manual (recommended)

*\* Asterisk denotes tools that are not required for some applications. Thoroughly read instructions first to determine which tools will be required for your application.*

## Recommended Upgrade

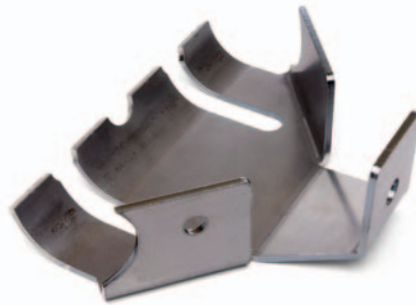

*Due to the alarming number of 2007+ Wrangler JK owners that have reported rear track bar failure, we strongly recommend the installation of our Rear Trackbar Brace PN OGS169. The majority of failures occur on lifted applications when an aftermarket extension bracket has been installed, although failures have also been reported on some stock applications.*

## Parts

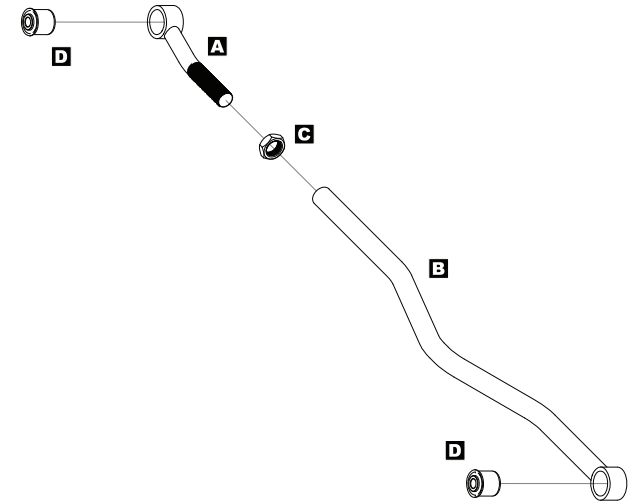

	DESCRIPTION	QTY
<b>A</b>	Male Threaded (Chassis) End	<b>1</b>
<b>B</b>	Female Threaded (Axle) End	<b>1</b>
<b>C</b>	1" NF Jam Nut	<b>1</b>
<b>D</b>	Rubber Bushing	<b>2</b>

## Installation

- 1. REMOVE REAR TRACK BAR**
  - Raise and support the vehicle chassis with jack stands positioned in front of the rear lower suspension arm brackets.
  - Raise and support the rear axle housing with a hydraulic jack to relieve any tension from the mounting bolts.
  - Remove the rear track bar mounting hardware from the axle and chassis brackets per the factory service manual instructions for your vehicle. Retain original hardware.
  - Remove original track bar from vehicle.

## ❑ 2. MOUNT ADJUSTABLE TRACKBAR TO AXLE BRACKET

- Apply anti-seize lubricant to bolt threads of original track bar mounting hardware.
- Insert Axle End (B) of Adjustable Trackbar into the axle bracket.

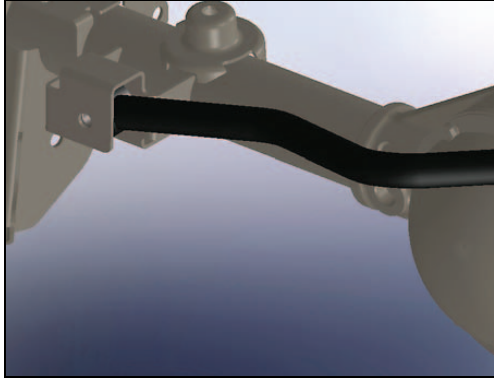

- Loosely install the original mounting hardware.

## ❑ 3. CENTER REAR AXLE HOUSING

- Remove jack stands and lower vehicle to ground. **HINT:** Vehicle must be at normal ride height, on level ground, with the suspension supporting the full vehicle weight.
- Determine if the axle housing is centered by measuring the distance between the tire and chassis, using the exact same points on each side of the vehicle to ensure accuracy.



**HINT:** For example, measure from the edge of a tire tread lug to the outboard side of the chassis, then repeat the measurement on the other side of vehicle using exact same points.

- If the two measurements are equal, the axle is centered. If the measurements vary, divide the difference in half to determine the amount of adjustment required. **HINT:** If the axle housing is not centered, the chassis can be laterally shifted using either of the following methods.

### Ratchet Strap (preferred)

- Attach a heavy duty ratchet strap to the chassis on one side of the vehicle, and to the axle housing on the other side.
- Tighten the strap in small increments to pull the chassis in alignment with the axle.
- Take measurements after each adjustment until centered.

### Pushing Vehicle Body

Although this method will laterally shift the chassis relative to axle housing, it does not enable the position to be easily stabilized while measurements are taken.

- With the vehicle safely on the ground, have a partner gently push on the vehicle body above the rear wheels.
- Take measurements while your partner maintains pressure on the vehicle body.

## ❑ 4. SET ADJUSTABLE TRACKBAR LENGTH AND MOUNT TO CHASSIS

- With the axle housing centered beneath the chassis, adjust the length of Adjustable Trackbar by rotating the Chassis End (A) until steel sleeve in Rubber Bushing (D) aligns with the mounting holes on the chassis bracket.
- Apply anti-seize lubricant to original mounting bolt threads and adjustment threads of trackbar.

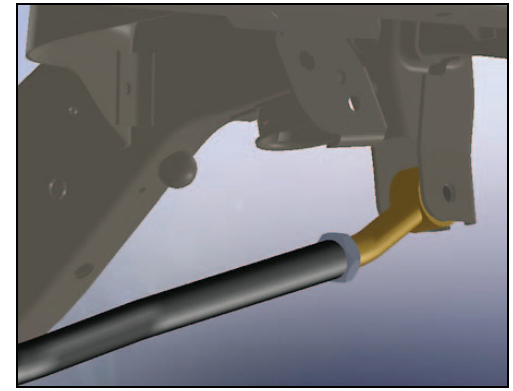

**HINT:** Bend in chassis (gold) end of trackbar must point down to prevent interference from occurring when suspension articulates.

- Mount Chassis End (A) of Adjustable Trackbar to the chassis bracket by loosely installing the original mounting hardware.

## ❑ 5. POST-INSTALLATION

- Take measurements again to ensure axle housing is perfectly centered and make any final adjustments if necessary.

**IMPORTANT:** The rear axle housing must be in perfect lateral alignment with vehicle chassis before you proceed with installation.

- Once all adjustments are complete, fully tighten the Jam Nut (C) to prevent Adjustable Trackbar length from changing. **HINT:** It may be easier to tighten Jam Nut with the Adjustable Trackbar removed from vehicle.
- Using a torque wrench, tighten mounting hardware at both ends of track bar to 125 ft-lbs.

## **Maintenance**

Check torque specifications regularly.

Regular cleaning with pressurized water is recommended to maximize reliability.

© 2011 JKS Manufacturing, Inc & Aftermarketing, LLC  
Revision Date 7/20/2011