

JKS[®]

Installation Instructions

Product: Bar Pin Eliminators™

Part Number: PN 9607

Application: Jeep Wrangler JK, 2007+

Welcome

CONGRATULATIONS on purchasing new Bar Pin Eliminators from JKS Manufacturing. We are committed to providing you with the best products available and your satisfaction is our first priority.

PLEASE READ these Installation Instructions carefully, and save them for future reference, as they contain important installation and maintenance information.

Important

NOT COMPATIBLE WITH Old Man Emu™ shock absorbers.

INSTALLATION OF BAR PIN ELIMINATORS effectively reduces the static length of shock absorber by 0.40".

Tools Required

- Metric/Standard Socket Wrench Set
- Torque Wrench
- Wheel Bearing Grease
- Bench Vice or C-Clamp
- Hammer and Punch *
- Sanding or Grinding Wheel *
- Factory Service Manual (recommended)

** Asterisk denotes tools that are not required for some applications. Thoroughly read instructions first to determine which tools will be required for your application.*

Parts

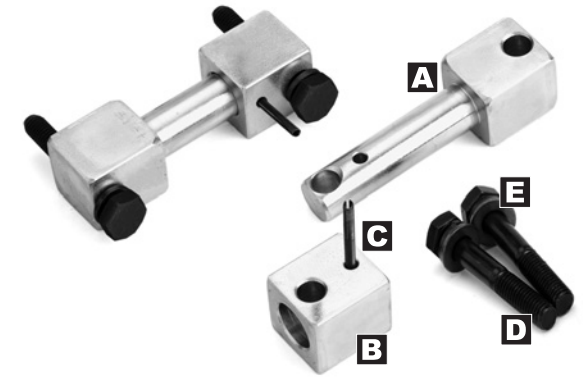

	DESCRIPTION	PART #	QTY
A	Cross Pin / Block Combo	PN 9607PB	2
B	Mounting Block	PN 960701	2
C	1/8" Roll Pin	PN 64083	2
D	M10 x 50mm Hex Bolt	PN 40698	4
E	Split Washer	PN 40253	4

Installation

❑ 1. REMOVE SHOCK ABSORBERS

- Remove the upper shock absorber mounting bolts from the chassis bracket.
- Remove the lower mounting bolt and nut from the axle bracket. Retain lower mounting hardware for reassembly.
- Remove the rear shock absorbers from the vehicle.
- Remove the factory bar pin from the upper shock absorber bushing. Discard the factory bar pin and upper mounting bolts. **HINT:** A hammer and punch may be useful for removing factory bar pin.
- Inspect shock bushings for wear and deterioration. If new bushings are needed, replace with standard 5/8" ID hourglass type bushings before installing Bar Pin Eliminators.

❑ 2. MOUNT BAR PIN ELIMINATOR TO SHOCK ABSORBER

- Apply a thin coating of wheel bearing grease to the Cross Pin (A).
- Insert Cross Pin (A) through upper bushing of shock absorber.

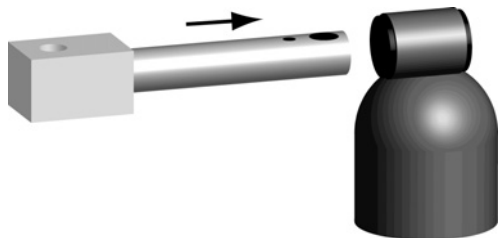

- Slide remaining Mounting Block (B) onto opposite end of Cross Pin (A), making sure bolt and roll pin holes are correctly positioned.

IMPORTANT: This product is designed to preload the shock absorber bushings for maximum performance and longevity. Therefore, you should find it necessary to compress the bushing approximately 1/16" to 1/8" before the mounting bolts and/or roll pins can be inserted.

If you are able to install the mounting blocks without compressing the shock bushing, insert a SAE 5/8" flat washer (not supplied) between the bushing and Mounting Block to ensure proper bushing preload.

- Squeeze Mounting Blocks together to compress the shock absorber bushing until bolt and roll pin holes align. **HINT:** A bench vice or C-clamp is useful for compressing shock bushing.
- Tap the 1/8" Roll Pin (C) through Mounting Block (B) and into corresponding hole in Cross Pin (A).

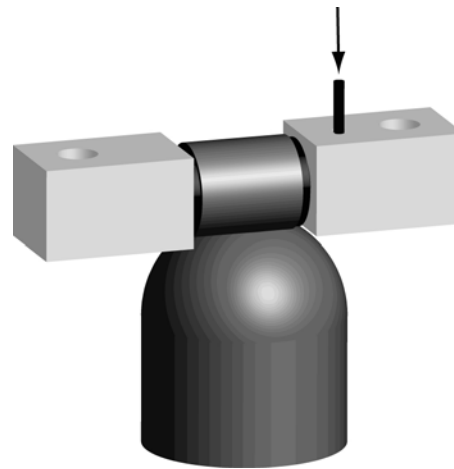

❑ 3. RE-INSTALL SHOCK ABSORBERS

- Clean any dirt or debris from the upper shock mounting surface on chassis. **HINT:** A sanding or grinding wheel is useful for removing any stubborn material.

- Place a Split Washer (E) on each of the supplied Hex Bolts (D).

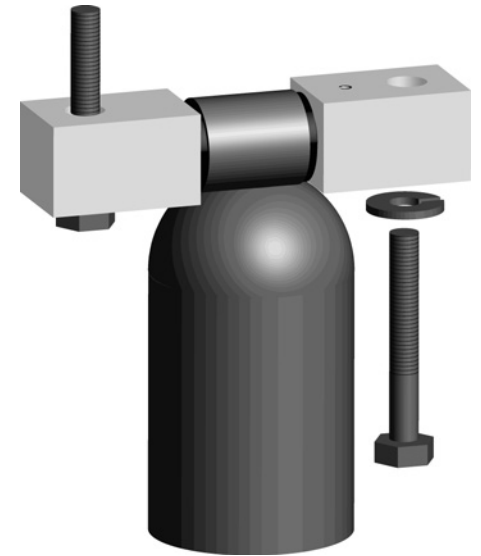

- Position Bar Pin Eliminator on mounting surface of chassis bracket. Insert 50mm Hex Bolts (D) through mounting blocks and thread into original shock mounting holes. **HINT:** Mounting Blocks of Bar Pin Eliminator must lay completely flat against surface of chassis bracket.
- Using a torque wrench, tighten 50mm Hex Bolts (D) to 25-35 ft-lbs.
- Install shock absorber to lower axle bracket using factory hardware.
- Using a torque wrench, tighten shock mounting bolt to 56 ft-lbs.

© 2009 JKS Manufacturing, Inc & Aftermarketing, LLC
Revision Date 7/25/2009