

JKS[®]

Installation Instructions

Product: Hydraulic BumpShocks

Part Number: PN BSE201

Application: Jeep Wrangler JK, 2007+ (front only)

Welcome

CONGRATULATIONS on purchasing a set of new Hydraulic BumpShocks from JKS Manufacturing! We are committed to providing you with the best products available and your satisfaction is our first priority.

PLEASE READ these Installation Instructions carefully, and save them for future reference, as they contain important installation and maintenance information.

Important

DO NOT EXCEED maximum range of bump shock adjustment – see illustration on page 3.

INSTALLATION of this product is not reversible and should only be performed by an experienced mechanic or fabricator.

Tools Required

- Hydraulic Floor Jack and Jack Stands
- Metric/Standard Socket Wrench Set
- Spanner or Strap Wrench *
(or similar tool for tightening Bump Shock Nut)
- Die Grinder with Cut-Off Wheel
(or reciprocating saw)
- File or Deburring Tool
- Emory Cloth (or similar paint stripping tool)
- Tape Measure
- Felt Tip Marker (or similar marking tool)
- Small Clamping Tool *
- Welding Equipment
- Drill with 3/8" Bit
- Coil Spring Compressor *
- Spray Lubricant (WD-40 or equivalent)
- Anti-Seize Lubricant
- Satin Black Spray Paint
- Factory Service Manual (recommended)

* Asterisk denotes tools that are not required for some applications. Thoroughly read instructions first to determine which tools will be required for your application.

Parts

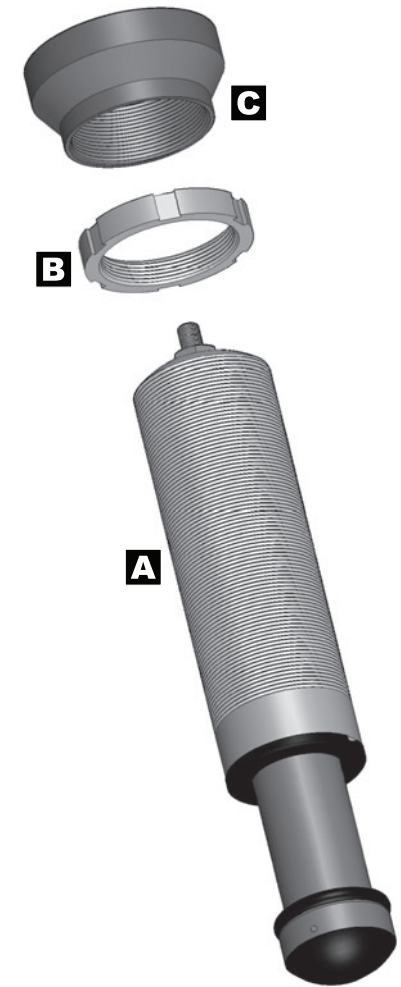

	DESCRIPTION	PART #	QTY
A	Bump Shock Assembly	PN RFC/BS02	2
B	Bump Shock Nut	PN RFC/SN50	2
C	Jounce Adapter	PN BSA001	2

Installation

1. REMOVE FRONT COIL SPRINGS

- Remove the front coil springs per the factory service manual instructions for your vehicle. **HINT:** A coil spring compressor is useful for removal.

Depending on the application, it may be necessary to completely or partially remove any of the following components before spring can be free from upper mount.

- Shock Absorber
- Swaybar
- Brake Line
- ABS Wire

2. MODIFY SPRING RETAINER

The factory bump stop holder is welded to the upper spring retainer and must be permanently removed in order to install the Hydraulic BumpShocks.

- Pry the original rubber bump stop (jounce bumper) free from the bump stop holder.

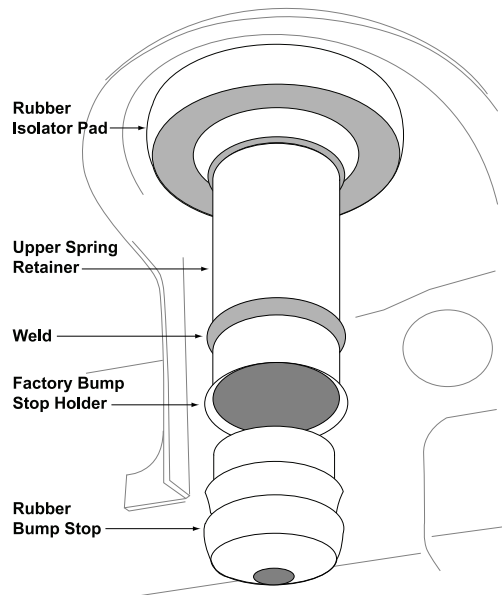

- Locate the factory weld that secures the bump stop holder to the upper coil spring retainer.

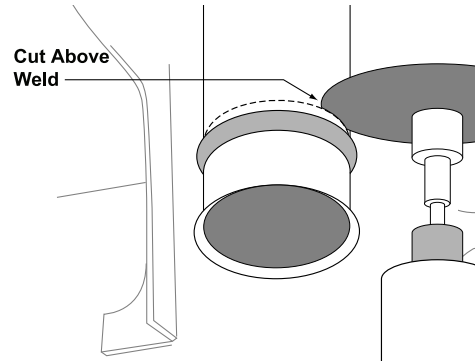

- Cut away the bump stop holder immediately above the weld as illustrated. **HINT:** A die grinder with cut-off wheel or reciprocating saw is useful for cutting away the bump stop holder.

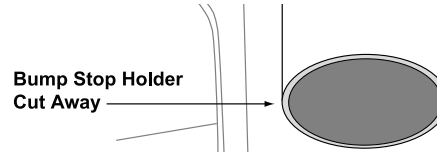

- Remove any sharp edges from the cut portion of the upper spring retainer. **HINT:** A file or deburring tool is useful for removing sharp edges.

3. PREPARE FOR WELDING

- Locate the supplied Jounce Adapters (C). The adapters are zinc plated from the factory to prevent corrosion. In preparation for welding, a small amount of plating must be removed to ensure the areas to be welded are clean.
- Slide the enlarged (non-threaded) end of the Jounce Adapter (C) onto the upper spring retainer until fully seated. Hold in position while completing the next step.
- Mark the perimeters of the upper spring retainer AND the Jounce Adapter (C) where they meet at three (3) locations that are accessible for welding. Each weld location should be at least 1/2" in length and spaced evenly apart. **HINT:** A felt tip marker or similar marking tool is useful for marking weld locations.

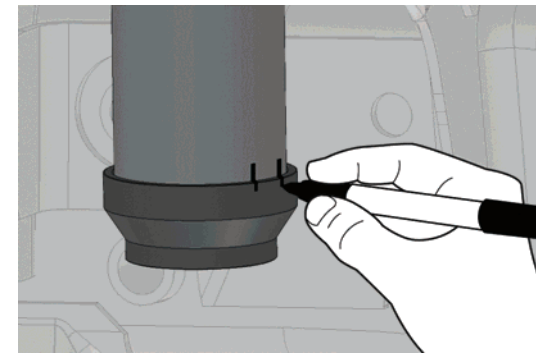

HINT: A pair of vertical lines spaced 0.5" apart is used to mark each weld location.

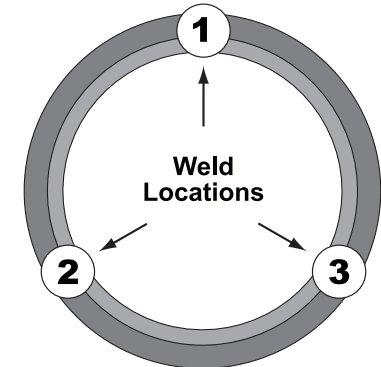
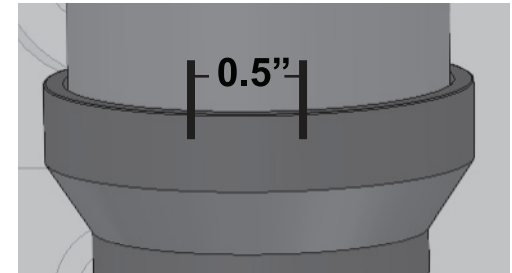

- Remove Jounce Adapter (C) from upper spring retainer and locate the weld location markings on the adapter and upper spring retainer.
- Remove the zinc plating from the marked locations on the Jounce Adapter (C). Also remove the factory paint from the corresponding locations on the upper spring retainer. **HINT:** Emory cloth or a suitable stripping tool is useful for removal of coatings. Make sure bare metal is completely exposed and free of contaminants to ensure proper weld penetration.

4. INSTALL JOUNCE ADAPTER ON PREPARED SPRING RETAINER

- With your welding equipment powered up and ready to go, reposition the Jounce Adapter (C) on the upper spring retainer, making sure the locations prepped for welding are in alignment.

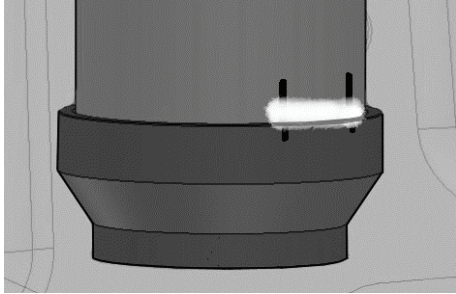

- Hold or clamp the Jounce Adapter (C) in position and tack weld the adapter to the spring retainer at each location. Make sure the adapter has remained fully seated against the spring retainer before proceeding.
- Next, weld a 1/2" long bead over each tack weld to ensure the Jounce Adapter (C) remains secured to the upper spring retainer. **HINT: As long as you achieve proper weld penetration on the adapter and spring retainer, it is not necessary to weld around the entire perimeter.**

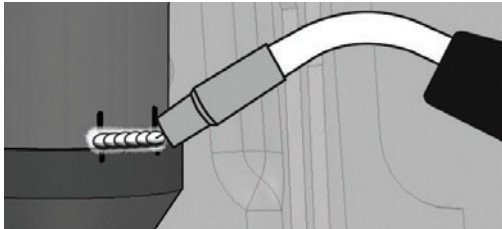

- Allow the welded sections to cool and then drill a 3/8" hole through the upper spring retainer immediately above one of the stitch welds. The purpose of the hole is to facilitate the evacuation of any moisture that may collect inside the retainer.

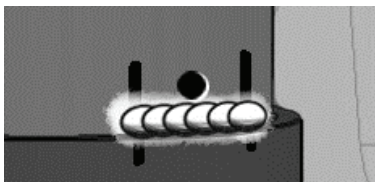

- To prevent corrosion, it will be necessary to paint all exposed surfaces on the Jounce Adapter (C) and spring retainer. Prepare for painting by thoroughly cleaning any dirt, debris or deposits from the area. **HINT: A clean piece of emory cloth or equivalent is useful for preparing the area to be painted.**
- Completely cover the exterior of the Jounce Adapter (C) and all exposed metal on the upper spring retainer with satin black spray paint. Protect inner threads of adapter from overspray.

5. INSTALL BUMP SHOCK ASSEMBLY

- Apply anti-seize lubricant to internal threads of Jounce Adapter (C) and Bump Shock Nut (B).
- Completely thread the Bump Shock Nut (B) onto Bump Shock Assembly (A).
- Thread Bump Shock Assembly (A) into Jounce Adapter (C) as far as possible.

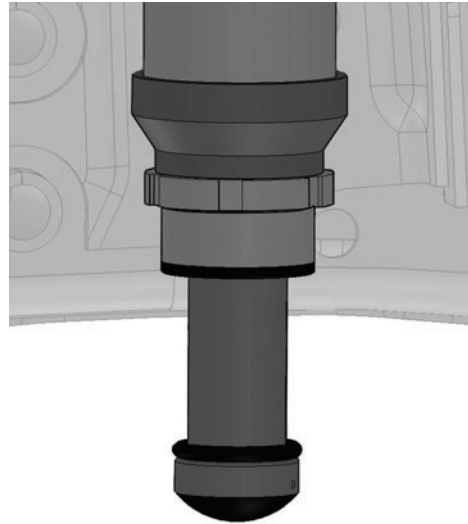

6. RE-INSTALL FRONT COIL SPRINGS

- Re-install the front coil springs per the factory service manual instructions for your vehicle. **HINT: A coil spring compressor is useful for installation.**
- Also re-install any of the components that were removed during the REMOVE FRONT COIL SPRINGS section of this installation.

7. ADJUST BUMP SHOCK POSITION

The ideal bump shock position is determined by the vehicle suspension and varies for each application.

- To properly set the bump shock position for your vehicle, you must first decide the point at which suspension compression should be limited. Take into consideration coil springs, shock absorbers, tire clearance, or any other factors that cause the vehicle to bottom out.

IMPORTANT: Because it replaces the original rubber bump stop, the bump shock should determine the limit of compression travel. The bump shock should be fully compressed when the suspension reaches maximum desired compression.

- With the vehicle on level ground and the suspension at full droop, extend the Bump Shock Assembly (A) to the desired position.

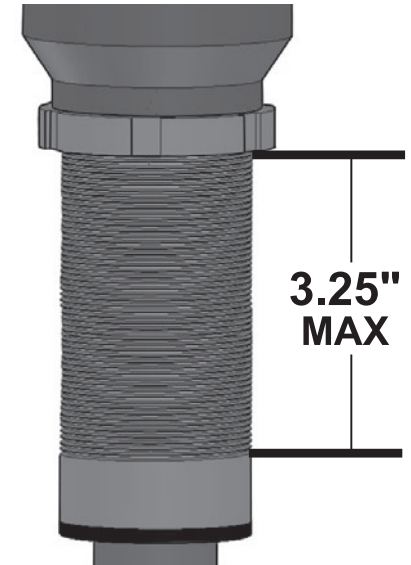

IMPORTANT: Internal threads of Jounce Adapter must remain fully engaged with Bump Shock Assembly at all times. Never operate vehicle when more than 3.25" of bump shock threads are exposed as illustrated above.

- Once the Bump Shock Assembly (A) is properly adjusted for your application, lock in place by turning the Bump Shock Nut (B) clockwise until it contacts the Jounce Adapter (C) and tighten. **HINT:** A spanner or strap wrench is useful for tightening Jounce Adapter Nut.

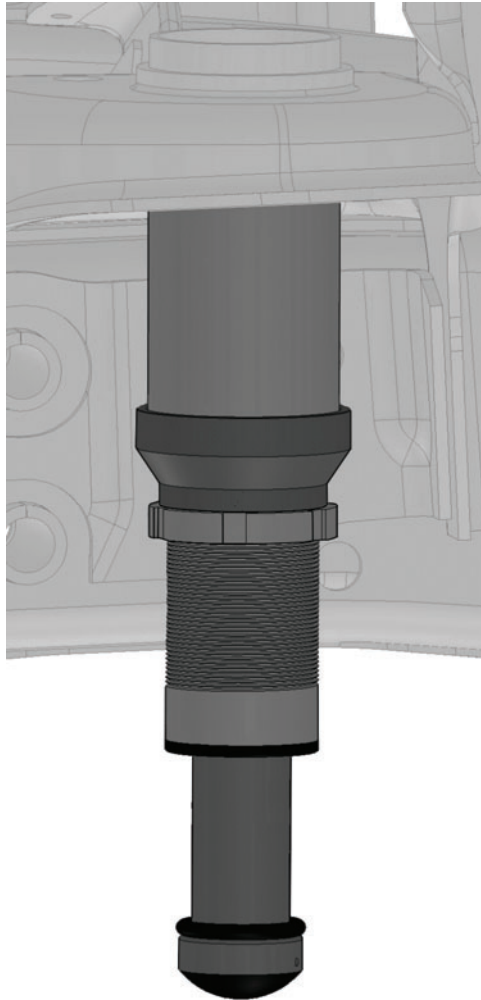

IMPORTANT: The suspension must be fully cycled to test for bump shock alignment and interference issues before the vehicle can be safely operated. The bump shock must contact the center portion of the lower spring pad at full compression, and there should be no interference between the bump shock and coil spring at full extension.

If you encounter any interference issues, contact JKS Manufacturing immediately for technical assistance.

JKS Technical Department	
Phone	(308) 762-6949
E-mail	tech@jksmfg.com

Operation

Bump Shock Adjustments

Future bump shock adjustments should be made with **NO LOAD** on the front coil springs, and the suspension at **FULL DROOP**.

Never attempt to adjust the Bump Shock Assembly (A) while under tension and always apply spray lubricant to threads before adjusting for ease of operation.

Bump Shock Pressure

The Bump Shock Assembly (A) is pre-charged with the proper amount of Nitrogen gas to suit most applications. Therefore it should not be necessary to adjust bump shock pressure prior to installation.

The Nitrogen charge is factory preset at 150 psi. For applications that require a higher or lower compression rate, the gas pressure can be manually adjusted to a minimum of 100 psi and a maximum of 200 psi.

To adjust pressure, the Bump Shock Assembly (A) must be removed from the vehicle. Nitrogen pressure is adjusted through the Schrader valve on top of the bump shock. Care should be taken when discharging the bump shock to ensure that no oil is lost. Most shops that service off-road racing or motorcycle shock absorbers can adjust bump shock pressure.



Maintenance

Regular cleaning with pressurized water is recommended to maximize ease of operation and reliability.

In addition, the 3/8" drainage holes that you drilled immediately above the Jounce Adapters (C) must be checked periodically for blockages. If necessary, clear debris from the holes to ensure any moisture trapped inside spring retainer is able to self-evacuate.

© 2011 JKS Manufacturing, Inc & Aftermarketing, LLC
Revision Date 3/25/2011