

JKS[®]

Installation Instructions

Product: Quick Disconnects™

Part Number: PN 5006 / 5007 / 9300 / 9400

Welcome

CONGRATULATIONS on purchasing a set of new Quick Disconnects™ from JKS Manufacturing. We are committed to providing you with the best products available and your satisfaction is our first priority.

PLEASE READ these Installation Instructions carefully, and save them for future reference, as they contain important installation and maintenance information.

Important

NOT COMPATIBLE WITH aftermarket swaybars. Install product with Original Equipment swaybar only.

SOME VEHICLES MAY REQUIRE extended front brake hoses or other modifications to compensate for additional suspension travel.

NEVER DISCONNECT swaybar when operating vehicle on public roads.

WHEN DISCONNECTED, swaybar must be secured to prevent interference with other suspension components or axle.

Tools Required

- Metric/Standard Socket Wrench Set
- Torque Wrench
- Angle Measuring Tool
- Grease Gun with Attachment for Flush Mount Zerk Fittings
- Wheel Bearing Grease

Parts

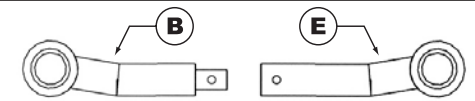
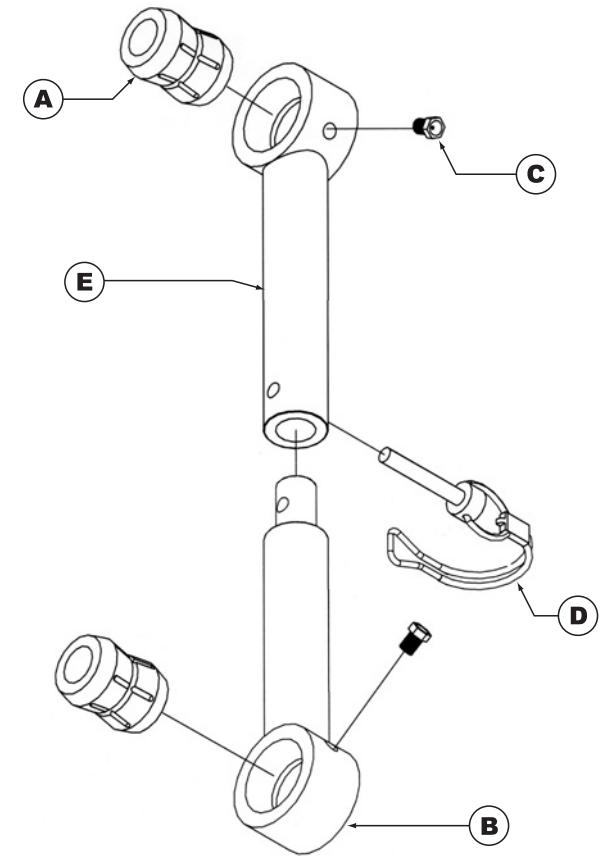

Part #9400 & #5007 (angled)

A	5/8" Polyurethane Bushing
B	Lower Male End
C	Flush Mount Grease Zerk
D	Stainless Steel Lynch Pin
E	Upper Female End

Installation

❑ 1. REMOVE ORIGINAL EQUIPMENT (OE) SWAYBAR LINKS

- Remove front swaybar drop links per the factory service manual instructions for your vehicle. Retain the original mounting hardware as it is required for Quick Disconnect installation.

❑ 2. MOUNT UPPER ENDS TO SWAYBAR

- Install Upper Female End (E) of Quick Disconnect to outboard side of swaybar, ensuring Grease Zerk (C) is facing forward.

IMPORTANT: Female end must be mounted on top to prevent it from collecting mud and debris.

- Secure Upper End (E) with the original tapered mounting bolt and hardware. Tighten to 40-50 ft-lb. using a torque wrench.

❑ 3. MOUNT LOWER ENDS TO AXLE

- Install Lower Male End (B) of Quick Disconnect to the front axle U-bolt plates, ensuring Grease Zerk (C) is facing forward.
- Secure Lower End (B) with the original mounting hardware. Tighten until all threads on nut engage the OE mounting stud, but do NOT overtighten polyurethane bushing.

❑ 4. MEASURE ANGLE OF SWAYBAR

- With the Quick Disconnects installed, and the vehicle on level ground and at normal ride height, measure swaybar angle to ensure it complies with the Acceptable Range below.

Vehicle	Part Number	Ideal Swaybar Angle (Acceptable Range)
YJ Wrangler	PN 5007	5°
	PN 9400	(0°-10°)
CJ5/CJ7/CJ8	PN 5006	5°
	PN 9300	(0°-10°)

HINT: See illustration of swaybar angle at top of next column.

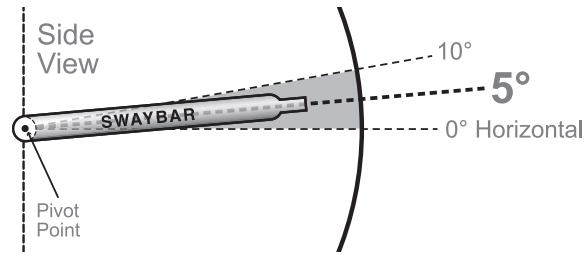

❑ 5. DISCONNECT AND RECONNECT ENDS OF QUICK DISCONNECT

HINT: Always disconnect and reconnect swaybar with vehicle on level ground and at normal ride height.

- Remove the Stainless Steel Lynch Pins (D) to disconnect swaybar.
- Rotate the swaybar up and out of the way.

IMPORTANT: When disconnected, the swaybar must be secured to vehicle chassis to prevent interference with suspension components or axle. Use plastic wire ties, bungee cord or equivalent.

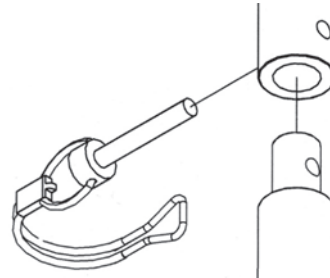

- To reconnect, rotate swaybar down and align both ends of Quick Disconnect so that male and female union slides together.
- Insert Stainless Steel Lynch Pin (D) through the male/female union to secure Quick Disconnect ends and lock the lynch pin in place.
HINT: It is normal to experience some difficulty when removing or inserting lynch pins following initial installation. Vehicle must be driven for a few days to break in Quick Disconnects and allow lynch pins to seat. With use, lynch pins will become easier to remove/insert.

❑ 6. LUBRICATE QUICK DISCONNECTS

Flush mount grease zerks require special grease gun attachment available at any auto parts store – use Lincoln® PN 83278 or equivalent.

- Lubricate all Grease Zerk fittings (C) on Quick Disconnects immediately after installation using common wheel bearing grease or equivalent.

Troubleshooting

If swaybar does not rotate freely, remove from vehicle, clean and apply rubber lubricant to chassis-mounted bushings, and reinstall.

90% of all Quick Disconnect problems are related to the leaf spring U-bolt plates, which must be parallel with the axle housing to ensure proper alignment of male and female ends. U-bolt plate alignment (fore/aft & side/side) and design are critical to Quick Disconnect operation.

The remaining 10% of problems are related to inconsistent swaybar manufacturing tolerances (swaybar twisted from factory), unevenly distributed vehicle weight (including accessories & passengers) and operation on unlevel surfaces.

If Stainless Steel Lynch Pins (D) are still difficult to remove after break in period, and you've already confirmed that the male and female ends are properly aligned, drill through the lynch pin hole (with Quick Disconnect connected) using a 1/4" drill bit.

OE shock bracket should not make contact with Quick Disconnect body – check near bend. Grind or hammer shock bracket to prevent interference if necessary.

PN 5007, 9400 only – Wrangler models.

Maintenance

Quick Disconnects should be lubricated regularly as part of vehicle maintenance schedule.

Regular cleaning with pressurized water is recommended to maximize ease of operation and reliability. Always lubricate afterwards to evacuate any moisture.

© 2009 JKS Manufacturing, Inc & Aftermarketing, LLC
Revision Date 8/5/2009