

Wiring Your Lights...

1. Find a suitable flat surface that has an open space behind (like the fairing), drill a 1/2" hole and mount the switch.
2. Remove the fuse from the red wire.
3. Plug the red and black wire set into the appropriate red and black wires on the light furthest (#1) from the switch. (see diagram)
4. Cut the terminals off of light #2. As you run the wire set past light #2, attach light #2 red and black wires using the enclosed wire splices.
5. Continue routing the red harness wire back to the switch and plug it into one of the switch wires.
6. Attach the fused red wire to the other switch wire and route it back to the positive (+) battery terminal.
7. Route the black wire back to the battery and attach to the negative (-) post or other suitable ground.
8. Use the enclosed wire ties and protective tubing as needed to secure and protect the wiring.
9. Replace the fuse in the red wire and test your lights.
10. Adjust lights as needed.
11. YOUR DONE!

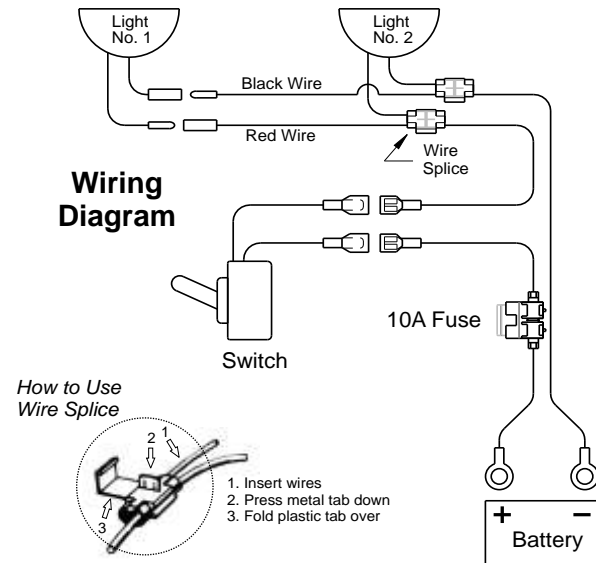

IF YOU HAVE ANY PROBLEMS OR QUESTIONS, PLEASE CALL
CUSTOMER SERVICE AT 800-528-0950

23 Year Warranty

See details on our website at
www.kchilites.com