



INTAKE SYSTEMS FOR VEHICLES LISTED ARE 50 STATE LEGAL. SEE KNFILTERS.COM FOR CARB STATUS ON EACH PART FOR A SPECIFIC VEHICLE.

INSTALLATION INSTRUCTIONS

57-1002

BMW 3 SERIES (E46)

1999-00 323i, ci

2001-05* 325i, ci

L6-2.5L

1999-00 328i

2000 328ci

2002-05 325xi

L6-2.8L

NOTE: * Excluding 2005 PZEV model with engine family 5BMXV02.5M56

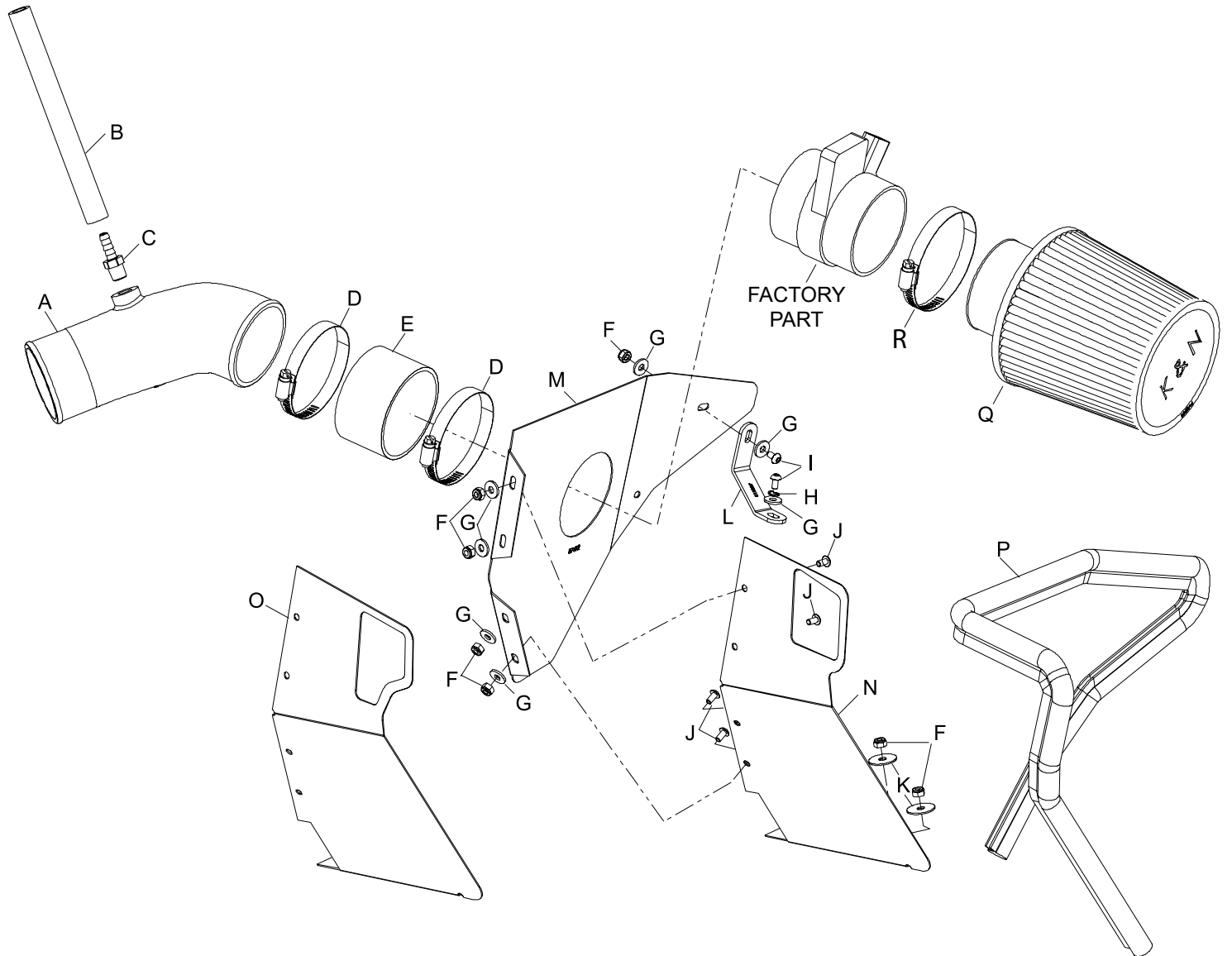

TOOLS NEEDED:

- Flat Blade Screwdriver
- Ratchet
- Extension
- 10mm Socket
- 10mm Wrench
- 4mm Allen

PARTS LIST:

| Description | Qty. | Part # | Description | Qty. | Part # | Description | Qty. | Part # |
|----------------------------|------|---------|---------------------------|------|--------|-------------------|------|---------|
| A INTAKE TUBE; EL | 1 | 087139A | G WASHER; 1/4"ID X 5/8"OD | 7 | 08275 | M HEAT SHIELD "A" | 1 | 07492 |
| B HOSE; 8MM ID X 2.25"L | 1 | 08062 | H WASHER; 1/4" LOCK | 1 | 08198 | N HEAT SHIELD "C" | 1 | 07497 |
| C FITTING; 5/16", 1/4" NPT | 1 | 08908 | I BOLT; M6 X 1 X 16MM | 2 | 07730 | O HEAT SHIELD "B" | 1 | 07494 |
| D HOSE CLAMP #48 | 2 | 08601 | J BOLT; M6-1 X 12MM | 4 | 07794 | P EDGE TRIM; 46"L | 1 | 102487 |
| E HOSE 3.25"ID X 2"L | 1 | 08690 | K WASHER; 1"D X 1/4"HOLE | 2 | 08160 | Q AIR FILTER | 1 | RU-4730 |
| F NUT; 6MM NYLOCK | 7 | 07553 | L BRACKET; "C" | 1 | 010087 | R HOSE CLAMP; #48 | 1 | 08601 |

If you need any assistance please call 1-800-858-3333 to speak with a representative in our Customer Service Center before returning the product.

NOTE: FAILURE TO FOLLOW INSTALLATION INSTRUCTIONS AND NOT USING THE PROVIDED HARDWARE MAY DAMAGE THE INTAKE TUBE, THROTTLE BODY AND ENGINE.

TO START:

1. Turn off the ignition and disconnect the negative battery cable.

NOTE: Disconnecting the negative battery cable erases pre-programmed electronic memories. Write down all memory settings before disconnecting the negative battery cable. Some radios will require an anti-theft code to be entered after the battery is reconnected. The anti-theft code is typically supplied with your owner's manual. In the event your vehicles' anti-theft code cannot be recovered, contact an authorized dealership to obtain your vehicles anti-theft code.



2. Depress the wire-locking clip and disconnect the mass air sensor electrical connection.



3. Pull up on the four fresh air duct-retaining pins to release them from the radiator core support.



4. Lift up and remove the fresh air duct from the vehicle as shown.
NOTE: Disconnect the fresh air tube from the fresh air duct.



5. Loosen the hose clamp that secures the intake tube to the mass air sensor and then disconnect the intake tube from the mass air sensor as shown.

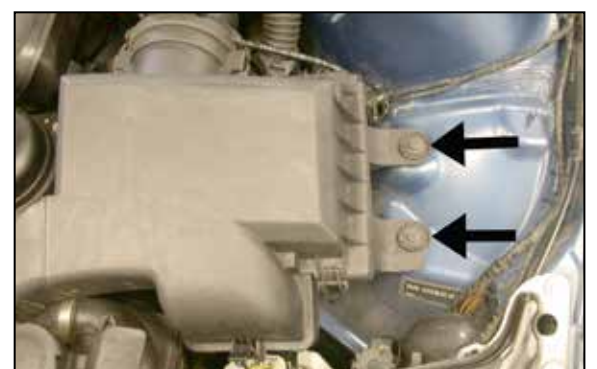

6. Remove the two factory air box mounting bolts shown.



7. Unhook the wiring harness from the rear of the factory air box.



8. Lift up and remove the air box from the vehicle.
NOTE: K&N Engineering, Inc., recommends that customers do not discard factory air intake.



9. Disconnect the vent tube from the factory intake tube as shown.



10. Loosen the lower hose clamp and remove the factory upper intake hose from the lower intake hose.



11. Unstrap the heater hose from the lower air box locator, and then pull up to remove the lower air box locator from the vehicle.



12. Install the provided 1/4" npt fitting into the intake tube as shown.
NOTE: Plastic NPT fittings are easy to cross thread. Install the vent fitting "hand" tight, then turn it two complete turns with a wrench.



13. Install the K&N® intake tube into the factory lower intake hose and secure with the factory hose clamp.

NOTE: Do not completely tighten the hose clamp at this time.



14. Remove the factory fresh air hose from the air box as shown.



15. Determine which style fresh air duct is used on your vehicle and choose the corresponding heat shield side panel that matches the assembly.



16. Assemble the heat shield using the side panel selected from step #15 and the provided hardware.



17. Install the provided edge trim onto the heat shield as shown.

NOTE: Some trimming of the edge trim may be necessary.



18. Trim the edge trim 1.5" as shown for clearance at the radiator water neck.

NOTE: Trim just the bulb portion of the edge trim leaving the pinched portion of the edge trim on the heat shield.



19. Release the two clips that secure the mass air sensor to the air box, then remove the mass air sensor as shown.



20. Install the silicone hose (08690) onto the mass air sensor and secure with the provided hose clamp.



21. Using a pair of pliers, carefully remove the wiring harness retaining clip from the inner fender as shown.



22. Install the mass air sensor assembly onto the K&N® intake tube and secure with the provided hose clamp.

NOTE: Do not completely tighten at this time.



23. Install the heat shield assembly into the vehicle and secure to the lower air box locating studs with the provided hardware as shown. Pass the mass air sensor through the hole in the heat shield.



24. Reinstall the lower rubber air box locator removed in step #11 and re-secure the heater hose.



25. Secure the wiring harness clip removed in step #21 to the heat shield as shown.

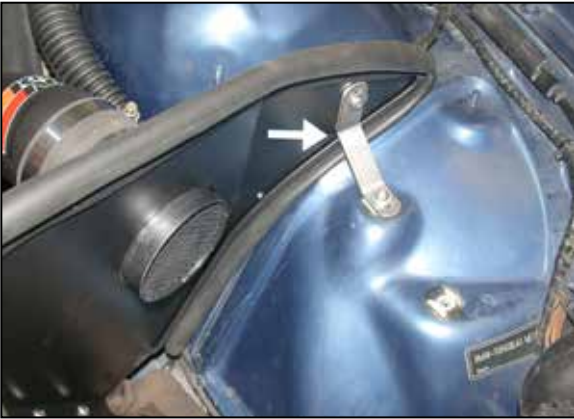

26. Install the provided bracket onto the heat shield and inner fender with the provided hardware as shown.

NOTE: The long portion of the bracket should attach to the heat shield.



27. Install the factory fresh air tube into the heat shield as shown.



28. Reinstall the fresh air duct removed in step #4 and secure with the four factory retaining pins.



29. Using the supplied silicone hose, attach the factory vent hose to the npt fitting on the intake tube.



30. Reconnect the mass air sensor electrical connection.



31. Install the air filter and secure with the hose clamp provided.

NOTE: Drycharger® air filter wrap; part # RU-4730DK is available to purchase separately. To learn more about Drycharger® filter wraps or look up color availability please visit <http://www.knfilters.com>®.



32. Reconnect the vehicle's negative battery cable. Double check to make sure everything is tight and properly positioned before starting the vehicle.

33. The C.A.R.B. exemption sticker, (attached), must be visible under the hood so that an emissions inspector can see it when the vehicle is required to be tested for emissions. California requires testing every two years, other states may vary.

34. It will be necessary for all K&N® high flow intake systems to be checked periodically for realignment, clearance and tightening of all connections. Failure to follow the above instructions or proper maintenance may void warranty.

ROAD TESTING:

1. Start the engine with the transmission in neutral or park, and the parking brake engaged. Listen for air leaks or odd noises. For air leaks secure hoses and connections. For odd noises, find cause and repair before proceeding. This kit will function identically to the factory system except for being louder and much more responsive.

2. Test drive the vehicle. Listen for odd noises or rattles and fix as necessary.

3. If road test is fine, you can now enjoy the added power and performance from your kit.

4. K&N Engineering, Inc., requires cleaning the intake system's air filter element every 100,000 miles. When used in dusty or off-road environments, our filters will require cleaning more often. We recommend that you visually inspect your filter once every 25,000 miles to determine if the screen is still visible. When the screen is no longer visible some place on the filter element, it is time to clean it. To clean and re-oil, purchase our filter Recharger® service kit, part number 99-5050 or 99-5000 and follow the easy instructions.

INTAKE SYSTEMS FOR VEHICLES LISTED ARE 50 STATE LEGAL. SEE KNFILTERS.COM FOR CARB STATUS ON EACH PART FOR A SPECIFIC VEHICLE.