



# INSTALLATION INSTRUCTIONS

**57-1506-2**  
**JEEP**  
**Grand Cherokee**  
**1993-98 V8-5.2L**  
**1998 V8-5.9L**

NOTE: This kit was not designed to fit vehicles with a body lift

**TOOLS NEEDED:**

- 7/16" Wrench or Socket
- 13mm Socket
- 3/4" Wrench or Socket
- Flat Blade Screwdriver
- 5mm Allen Wrench
- 4mm Allen Wrench
- 10mm Socket
- Ratchet

**PARTS LIST:**

Description	Part #	Qty.	Description	Part #	Qty.	Description	Part #	Qty.
A 1/4-20 Nylock Nut	07517	6	K Hose Clamp #6	08407	1	U Fender Washer 1"OD	08160	4
B Fender Washer 1.25"OD	08151	2	L Hose Clamp #60	08624	1	V Rubber Washer	21685	4
C Washer; 1.25x.30x.10 Rubber	21708	2	M Flat Head Allen Bolt	08376	1	W Rubber Isolator Stand Off	08005	2
D Intake Tube	08863	1	N Saddle	078855	1	X 6mm Allen Bolt	07852	1
E Gasket	09075	1	O Conical Nylon Washer	08180	1	Y Hose Clamp #64	08648	1
F Spacer	06402	2	P Flat Washer 5/8"od	08275	2	Z Air Filter Element	RF-1027	1
G Nut; 1/4-20, Hex, Zinc	07681	1	Q 6mm Nylock Nut	07553	1	AA Threadlocker	482	1
H Stud	08037	1	R Bracket	083156	1			
I Bolt; 1/4-20 X 2-1/4I, Tap	22209	1	S Trim Seal	102483	1			
J Bracket; Mild Stl. FB/PC	010129	1	T Heat Shield	08024	1			

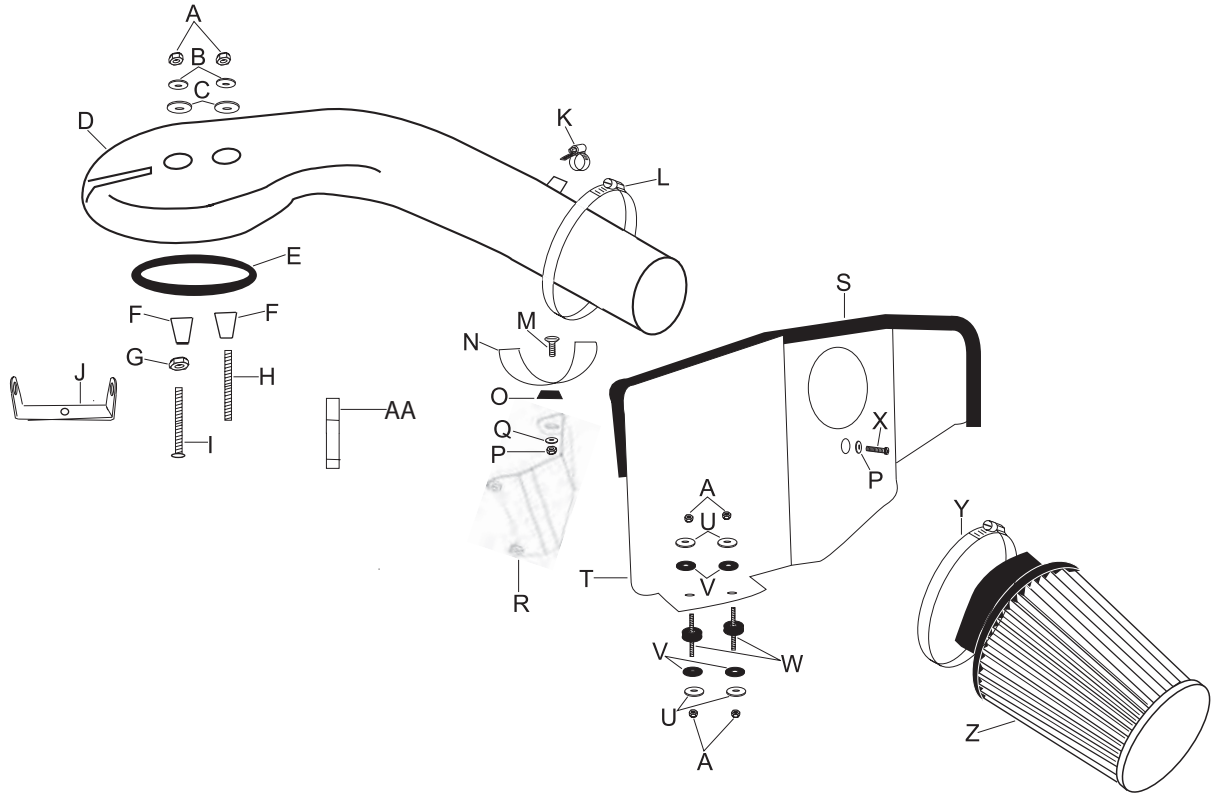

**NOTE: FAILURE TO FOLLOW INSTALLATION INSTRUCTIONS AND NOT USING THE PROVIDED HARDWARE MAY DAMAGE THE INTAKE TUBE, THROTTLE BODY AND ENGINE.**

**TO START:**

1. Turn off the ignition and disconnect the negative battery cable.  
**NOTE: Disconnecting the negative battery cable erases pre-programmed electronic memories. Write down all memory settings before disconnecting the negative battery cable. Some radios will require an anti-theft code to be entered after the battery is reconnected. The anti-theft code is typically supplied with your owner's manual. In the event your vehicles' anti-theft code cannot be recovered, contact an authorized dealership to obtain your vehicles anti-theft code.**

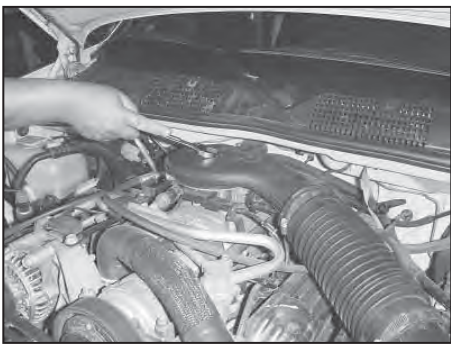

2. Loosen the nut at the intake plenum as shown.

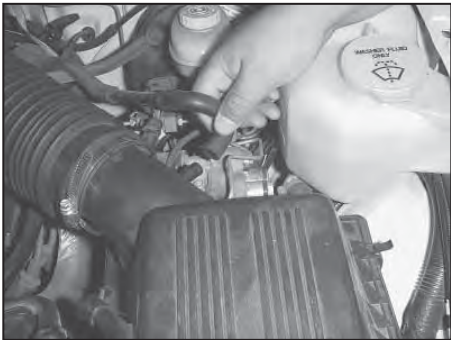

3. Disconnect the factory crankcase vent at the airbox.



4. Unclip the six over center clamps and remove complete upper intake assembly as shown.



5. Using a 1/2" socket, loosen and remove the three bolts that secure the airbox base.

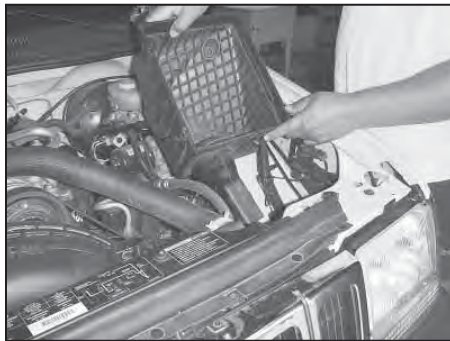

6. Remove the airbox base as shown.  
**NOTE: K&N Engineering, Inc., recommends that customers do not discard factory air intake.**



7. Using a 7/16" socket, loosen and remove the stud assembly as shown.



8. Install the two rubber isolator stand off using the provided hardware as shown.

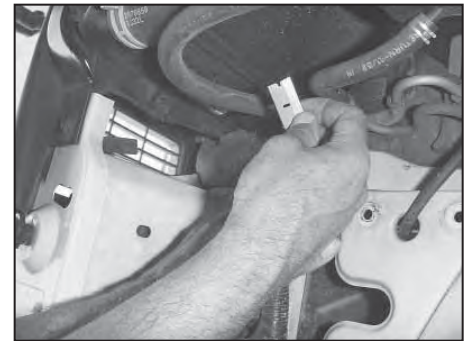

9. For maximum air, using a razor blade, cut the rubber splash guard to fully expose air from the grill.



10. Install the heat shield with the hardware provided.



11. Install the trim seal provided as shown above.

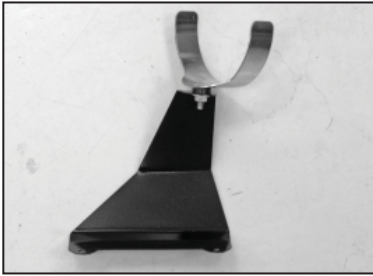

12. Assemble the saddle to the bracket using the hardware provided.

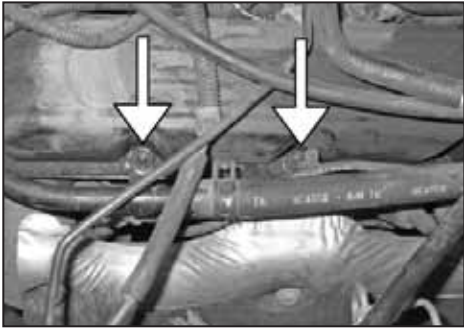

13. Remove the two valve cover retaining bolts shown. **NOTE: These bolts will be reused.**

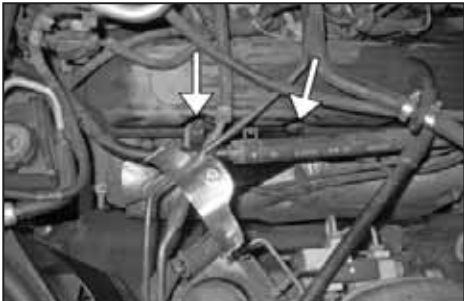

14. Install the saddle bracket assembly onto the valve cover as shown and secure with the factory bolts removed in step #13.

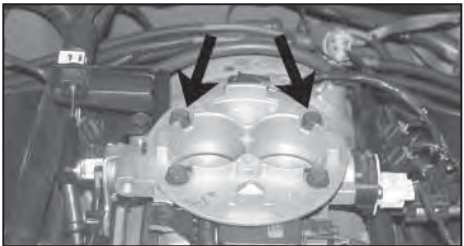

15. Remove the two rear throttle body bolts as shown.

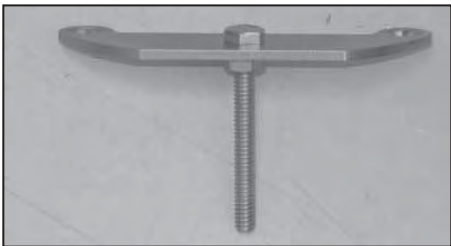

16. Install the provided 1/4"-20x2.25" bolt through the tube-mounting bracket and secure with the provided nut as shown.

**NOTE: Apply two drops of thread locker to the threads of the bolt and torque the nut to 30 inch-pounds.**



17. Install the tube mounting bracket assembly onto the throttle body and secure with the factory bolts removed in step #14. Torque the throttle body bolts to 17ftlbs.

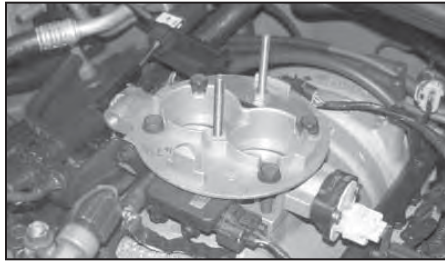

18. Install the provided stud into the threaded hole on the throttle body and tighten completely.

**NOTE: Apply two drops of thread locker to the stud and torque to 30 inch pounds. Failure to follow the above instructions may damage the throttle body.**

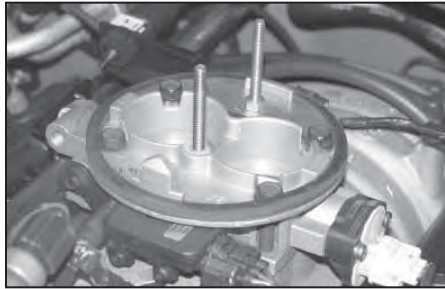

19. Install the provided gasket onto the throttle body sticky side down.

**NOTE: For extreme off road or dusty conditions, it is recommended that RTV silicone be applied to the gasket when it is installed.**

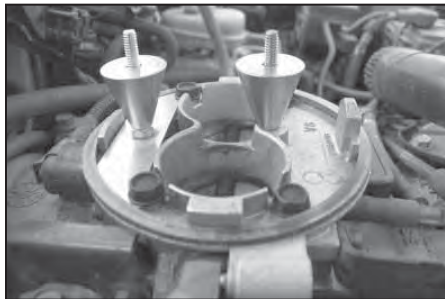

20. Install the provided stand off's onto the studs as shown.



21. Install the intake tube as shown.

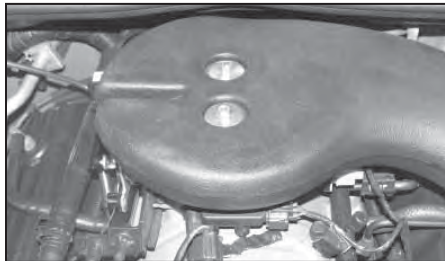

22. Secure the intake tube with the provided nut and washers as shown.



23. Install the hose clamp provided, around the saddle bracket and intake tube and tighten.

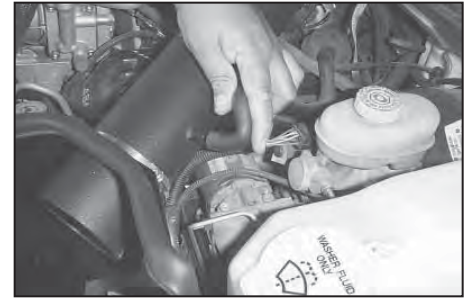

24. Install the crankcase vent hose onto the small fitting on the intake tube and secure with hose clamp provided.



25. Align and tighten the saddle bracket to the heat shield.



26. Install the air filter element onto the intake tube and tighten using the hose clamp provided.

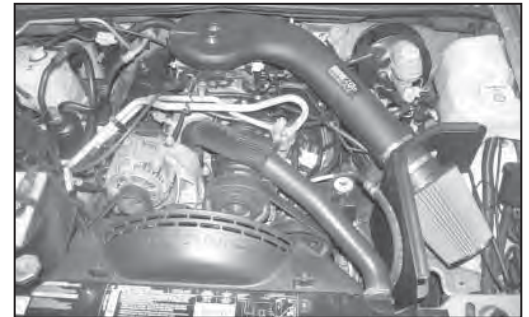

27. Reconnect the vehicle's negative battery cable. Double check to make sure everything is tight and properly positioned before starting the vehicle.

28. The C.A.R.B. exemption sticker, (attached), must be visible under the hood so that an emissions inspector can see it when the vehicle is required to be tested for emissions. California requires testing every two years, other states may vary.

29. It will be necessary for all K&N® high flow intake systems to be checked periodically for realignment, clearance and tightening of all connections. Failure to follow the above instructions or proper maintenance may void warranty.

#### ROAD TESTING:

1. Start the engine with the transmission in neutral or park, and the parking brake engaged. Listen for air leaks or odd noises. For air leaks secure hoses and connections. For odd noises, find cause and repair before proceeding. This kit will function identically to the factory system except for being louder and much more responsive.

2. Test drive the vehicle. Listen for odd noises or rattles and fix as necessary.

3. If road test is fine, you can now enjoy the added power and performance from your kit.

4. K&N Engineering, Inc., suggests checking the air filter element periodically for excessive dirt build-up. When the element becomes covered in dirt (or once a year), service it according to the instructions on the Recharger® service kit, part number 99-5050 or 99-5000.

**50-STATE STREET LEGAL**  
**K&N CARB EXEMPT K&N**

\* FREE K&N® decal To register your warranty, please see us online at [knfilters.com/register](http://knfilters.com/register). FREE K&N® decal \*

• 1455 CITRUS ST., P.O. BOX 1329, RIVERSIDE, CA., U.S.A. 92502 • TECH SERVICE 800-858-3333 • FAX 951-826-4001  
 • e-mail: [tech@knfilters.com](mailto:tech@knfilters.com) • WWW: <http://www.knfilters.com>