



AIRCHARGER™

HIGH-FLOW INTAKE KITS

NOT LEGAL FOR SALE OR USE ON ANY POLLUTION CONTROLLED MOTOR VEHICLE IN CALIFORNIA OR STATES ADOPTING CALIFORNIA EMISSION PROCEDURES.

See knfilters.com for CARB status on each part for a specific vehicle

INSTALLATION INSTRUCTIONS

63-2575

FORD / LINCOLN

2007-14 Expedition

2007-14 Navigator

2009-10 F-150

V8-5.4L

NOTE: This kit was not designed to fit vehicles with a body lift.

TOOLS NEEDED:

- Flat blade Screwdriver
- Ratchet
- Extension
- 8mm Socket
- 10mm Socket
- 13mm Socket
- 10mm Wrench
- T20 Torx Wrench
- 2.5mm Allen Wrench
- 4mm Allen Wrench

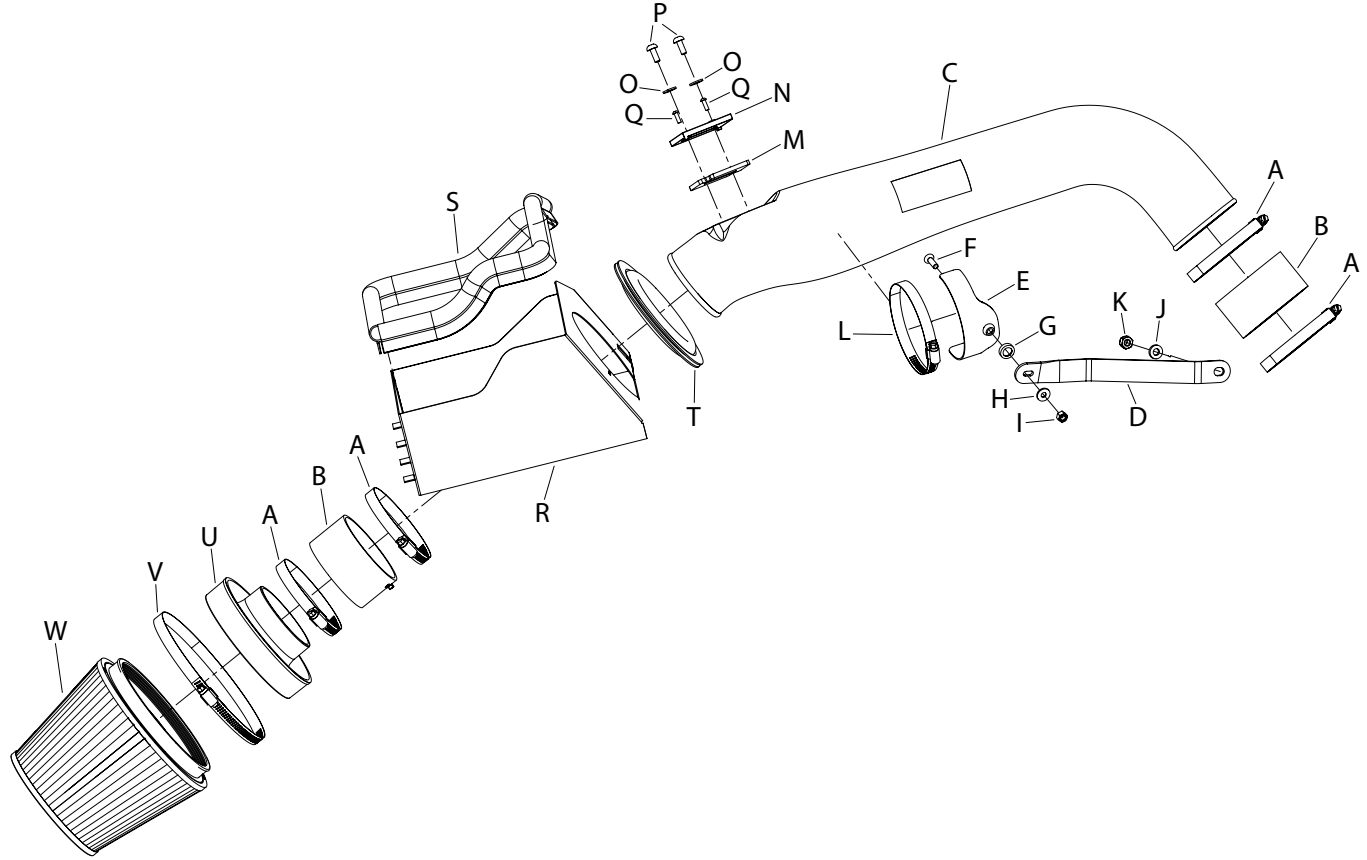

PARTS LIST:

Description	Qty.	Part #	Description	Qty.	Part #	Description	Qty.	Part #
A Hose Clamp #56	4	08620	I Nut; 6MM Nylock, Hexhead, SS	1	07512	Q Screw; M4- .7 X 12, Btnhd., SS	2	07726
B Hose; 3.5" ID X 2"L. Silicone	2	08630	J Washer; 5/16" ID X 5/8" OD, Flat	1	08276	R Heat Shield	1	07355-1
C Intake Tube	1	087220	K Nut, 8MM, Nylock	1	07542	S Edge Trim (42")	1	102499
D Bracket; "Z", STL, FB/PC	1	06508	L Hose Clamp #60	1	08624	T Edge Trim (17")	1	102469
E Bracket; Saddle, SS	1	078855	M Gasket; 3/16" Poron	1	09069	U Adaptor; #380	1	21512-1
F Bolt; 6MM-1.00 X 20MM F/H/A, SS	1	08376	N Adaptor; Nylopn 6/6 GF, Black	1	21515	V Hose Clamp #104	1	08697
G Washer; Conical, Nylon, Black	1	08180	O Washer; 6MM Flat, SS	2	08269	W Air Filter	1	RC-5173
H Washer; 1/4" ID X 5/8" OD-SAE	1	08275	P Bolt; M6 X 1.00 X 16MM, Btnhd., SS	2	07730			

NOTE: FAILURE TO FOLLOW INSTALLATION INSTRUCTIONS AND NOT USING THE PROVIDED HARDWARE MAY DAMAGE THE INTAKE TUBE, THROTTLE BODY, AND ENGINE.

TO START:

1. Turn off the ignition and disconnect the negative battery cable.

NOTE: Disconnecting the negative battery cable erases pre-programmed electronic memories. Write down all memory settings before disconnecting the negative battery cable. Some radios will require an anti-theft code to be entered after the battery is reconnected. The anti-theft code is typically supplied with your owner's manual. In the event your vehicles' anti-theft code cannot be recovered, contact an authorized dealership to obtain your vehicles anti-theft code.



2. Release the red locking tab and disconnect the mass air sensor electrical connection.



3. Remove the two bolts that secure the engine cover.

NOTE: Some vehicles may not be equipped with an engine cover.



4. Remove the engine cover as shown. **NOTE: Some vehicles may not be equipped with an engine cover.**



5. On the factory inlet tube, loosen the hose clamps at the upper air box housing and at the throttle body inlet.



6. Remove the factory inlet tube as shown.



7. Un-snap the three latches securing the upper air box housing to the lower air box housing as shown.



8. Remove the upper air box housing and air filter from the lower air box housing as shown.

NOTE: K&N Engineering, Inc., recommends that customers do not discard factory air intake.



9. Install silicone hose (#08630) onto the throttle body inlet tube with the provided hose clamps as shown.



10. Remove the two screws securing the mass air sensor, then remove the mass air sensor from the upper air box housing as shown.



11. Install the provided gasket onto the mass air sensor adapter as shown with the sticky side down.



12. Install the mass air sensor onto the mass air sensor adapter with the provided hardware as shown.



13. Install the mass air sensor assembly into the intake tube.
NOTE: Verify the open end of the mass air sensor is facing toward the "air filter end" of the intake tube.



14. Secure the mass air sensor assembly onto the intake tube with the provided hardware as shown.



15. Install the long edge trim onto the heat shield as shown.
NOTE: Some trimming of the edge trim may be necessary.



16. Install the short edge trim into the hole in the heat shield as shown.
NOTE: Some trimming of the edge trim may be necessary.



17. Remove the center latch from the lower air box as shown.



18. Install the heat shield and secure with the two remaining latches as shown.
NOTE: A gap is normal between the lower air box and heat shield on the clip side of the heat shield.



19. Install the saddle clamp onto the tube bracket (#06508) and secure with the provided hardware.



20. Install the tube bracket assembly onto the timing cover stud at the front of the engine as shown.



21. Install the air filter adapter into the K&N® air filter and secure with the provided hose clamp as shown.



22. Install silicone hose (#08630) onto the air filter adapter and secure with the provided hose clamp.



23. Place the air filter assembly into the heat shield as shown.



24. Install the intake tube into the air filter assembly and silicone hose at the engine inlet tube, then align with the tube bracket and secure with the provided hose clamps as shown.



25. Secure the K&N® air filter assembly onto the K&N® intake tube with the provided hose clamp as shown.



26. Re-connect the mass air sensor electrical connection as shown.

27. Re-connect the vehicle's negative battery cable. Ensure everything is tight and properly positioned before starting the vehicle.

28. It will be necessary for all K&N® high flow intake systems to be checked periodically for realignment, clearance and tightening of all connections. Failure to follow the above instructions or proper maintenance may void warranty.

ROAD TESTING:

1. Start the engine with the transmission in neutral or park, and the parking brake engaged. Listen for air leaks or odd noises. For air leaks secure hoses and connections. For odd noises, find cause and repair before proceeding. This kit will function identically to the factory system except for being louder and much more responsive.

2. Test drive the vehicle. Listen for odd noises or rattles and fix as necessary.

3. If road test is fine, you can now enjoy the added power and performance from your kit.

4. K&N Engineering, Inc., requires cleaning the intake system's air filter element every 100,000 miles. When used in dusty or off-road environments, our filters will require cleaning more often. We recommend that you visually inspect your filter once every 25,000 miles to determine if the screen is still visible. When the screen is no longer visible some place on the filter element, it is time to clean it. To clean and re-oil, purchase our filter Recharger® service kit, part number 99-5050 or 99-5000 and follow the easy instructions.

NOT LEGAL FOR SALE OR USE ON ANY POLLUTION CONTROLLED MOTOR VEHICLE IN CALIFORNIA OR STATES ADOPTING CALIFORNIA EMISSION PROCEDURES.

See knfilters.com for CARB status on each part for a specific vehicle

* FREE K&N® decal To register your warranty, please see us online at knfilters.com/register. FREE K&N® decal *