



AIRCHARGER[®]

HIGH-FLOW INTAKE KITS

NOT LEGAL FOR SALE OR USE ON ANY POLLUTION CONTROLLED MOTOR VEHICLE IN CALIFORNIA OR STATES ADOPTING CALIFORNIA EMISSION PROCEDURES.
See knfilters.com for CARB status on each part for a specific vehicle

INSTALLATION INSTRUCTIONS

63-2579

FORD

2010-14 Mustang GT500

V8-5.4L / 5.8L Supercharged

TOOLS NEEDED:

- Ratchet
- Extension
- 10mm Socket
- Flat Blade Screwdriver
- T20 TORX
- 3/4" Wrench
- 9/16" Wrench
- 10mm Wrench
- 4mm Allen Wrench
- 3mm Allen Wrench

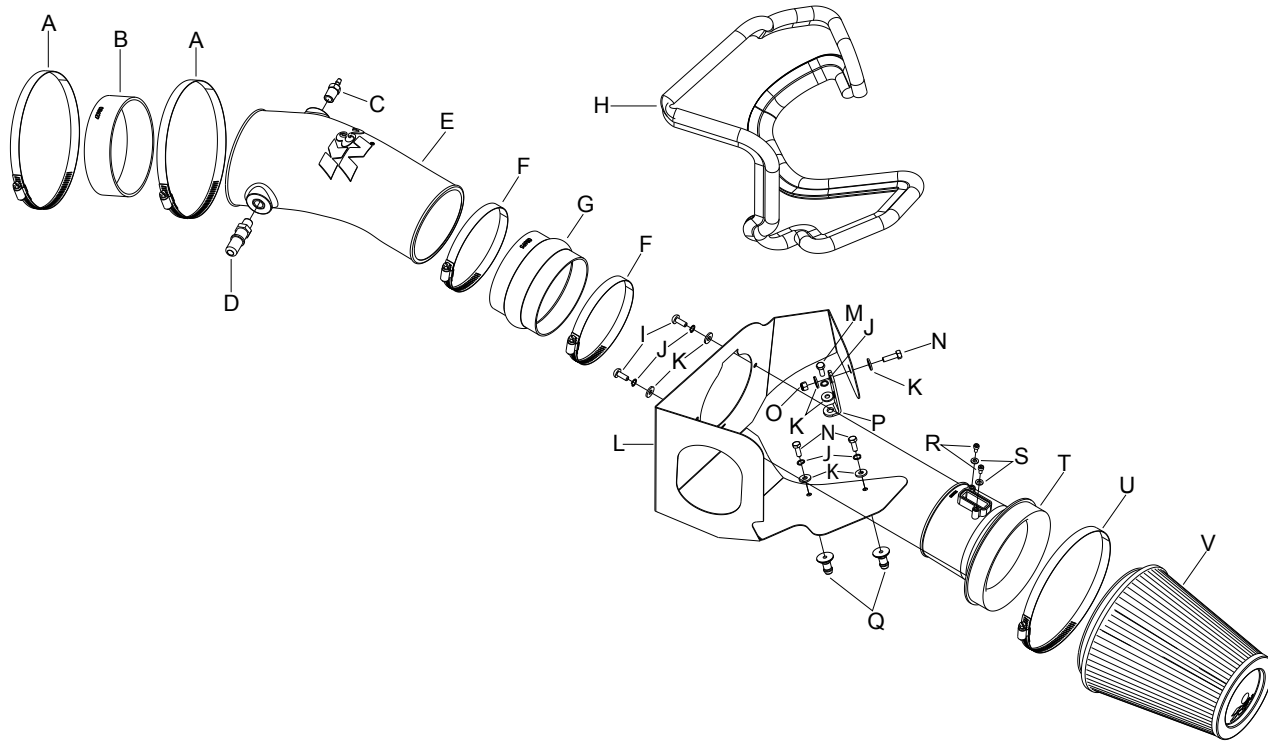

PARTS LIST:

Description	Qty.	Part #
A Hose Clamp #80 Stainless	2	08685
B Hose; 5" ID X 1-1/2" L Reinforced	1	08627
C Vent; Strt, 3/16 Barbed 1/4"NPT, Nylon	1	080021
D Vent; 1/4 NPT TO Quick Disconnect	1	082628
E Intake Tube (HZ)	1	087240
F Hose Clamp #72	2	08671
G Hose; 4-1/2" ID X 3" L Hump Reinforced	1	08695
H Edge trim (66")	1	102472
I Bolt; M6 X 1.00 X 16MM , Buttonhead, SS	2	07730
J Washer; 1/4" Lock, ZN	5	08198
K Washer; 1/4"ID X 5/8"OD - SAE	7	08275
L Heat Shield	1	074077
M Bolt; M6 X 1.00" X 20MM HEX, SS	1	07795
N Bolt; 6MM-1.00 X 16MM, SS	3	07812
O Nut; 6MM Nylock, Hexhead, SS	1	07512
P Bracket; 57-1532, SM."L", Mild STL. TB/PC	1	07158
Q Nipple, Heat Shield	2	8-186
R Bolt; M4 - 0.07 8MM, A/H CAP, SS	2	07733
S Washer; 5MM Flat, SS	2	08212
T Adapter; MAF Sensor Housing	1	088035
U Hose Clamp # 104	1	08697
V Air Filter	1	RF-1044

NOTE: FAILURE TO FOLLOW INSTALLATION INSTRUCTIONS AND NOT USING THE PROVIDED HARDWARE MAY DAMAGE THE INTAKE TUBE, THROTTLE BODY AND ENGINE.

TO START:

1. Turn off the ignition and disconnect the negative battery cable.

NOTE: Disconnecting the negative battery cable erases pre-programmed electronic memories. Write down all memory settings before disconnecting the negative battery cable. Some radios will require an anti-theft code to be entered after the battery is reconnected. The anti-theft code is typically supplied with your owner's manual. In the event your vehicles' anti-theft code cannot be recovered, contact an authorized dealership to obtain your vehicles anti-theft code.

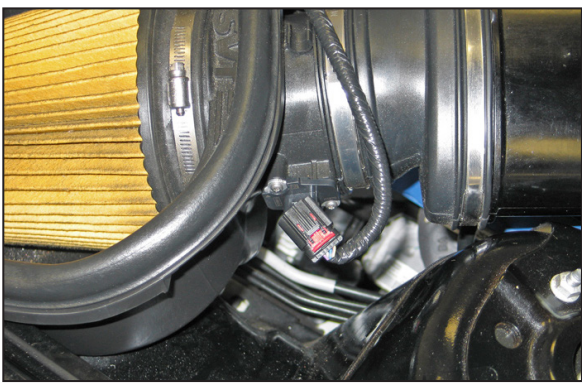

2. Release the red locking tab and then disconnect the mass air sensor electrical connection.

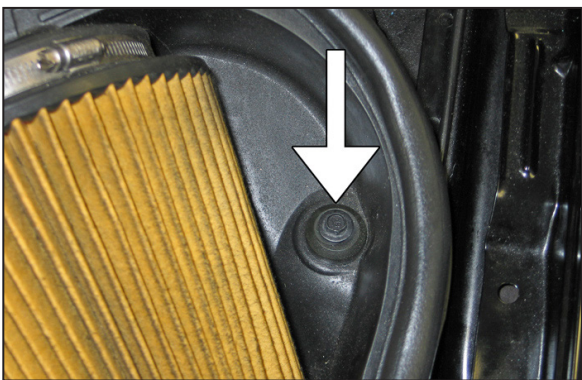

3. Remove the bolt that secures the airbox housing to the inner fender.

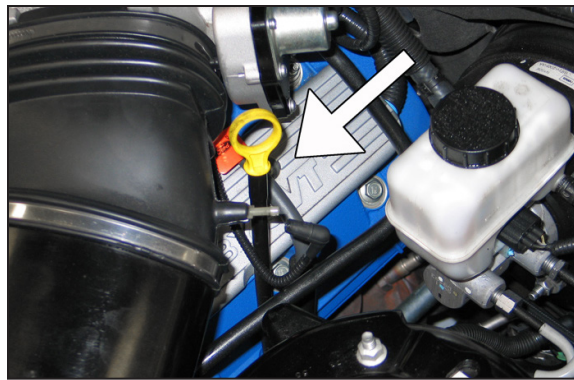

4. Disconnect the vacuum line from the stock intake tube as shown.

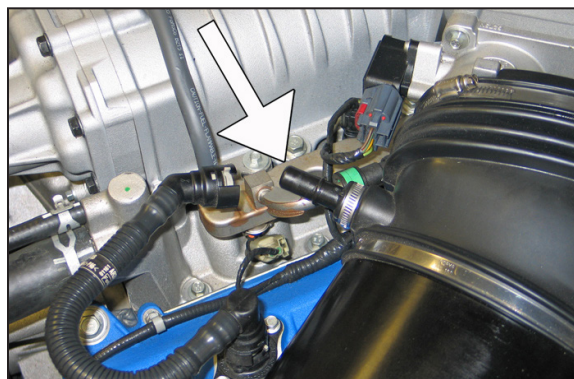

5. Rotate the locking ring and then disconnect the crankcase vent hose as shown.

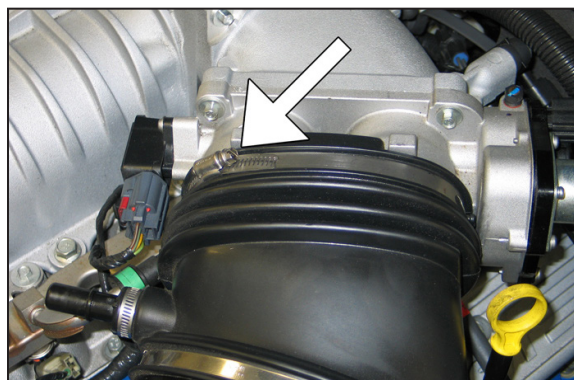

6. Loosen the hose clamp securing the stock intake tube to the throttle body.



7. Disconnect the intake tube from the throttle body and then remove the complete intake system from the vehicle.

NOTE: It will be necessary to unhook the mass air sensor harness from the airbox.

NOTE: K&N Engineering, Inc., recommends that customers do not discard factory air intake.

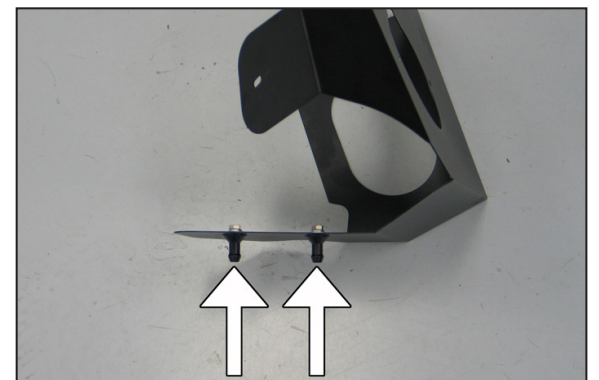

8. Install the heat shield mounting posts to the heat shield using the provided hardware as shown.

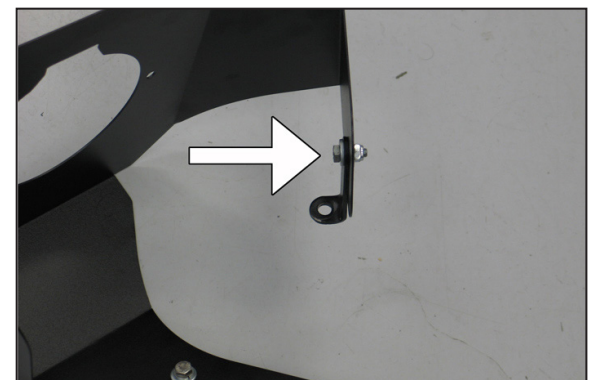

9. Install the heat shield mounting bracket (07158) onto the heat shield using the provided hardware.



10. Install the provided edge trim onto the heat shield as shown.

NOTE: Some trimming of the edge trim will be necessary.



11. Install the mass air sensor into the heat shield, rotate the sensor 180° so the sensor boss is pointed downward, and then secure with the provided hardware.

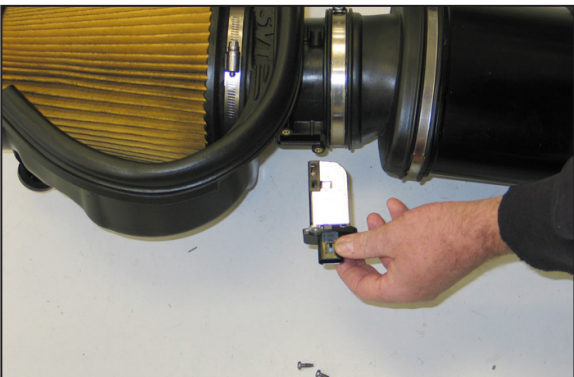

12. Remove the two screws securing the mass air sensor to the factory housing, then remove the mass air sensor as shown.



13. Install the mass air sensor into the K&N® mass air sensor housing and secure with provided hardware.

NOTE: Be sure to place the provided washers between the mass air sensor and housing.

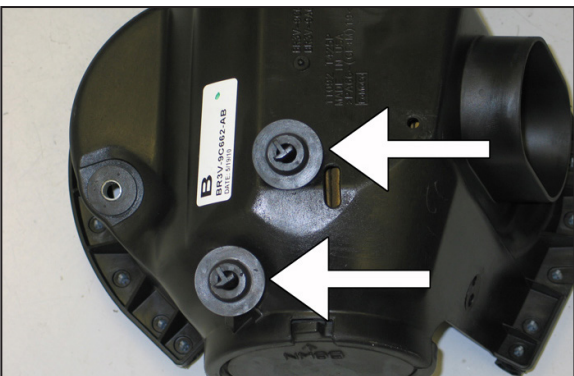

14. Remove the two factory mounting grommets shown from the airbox.

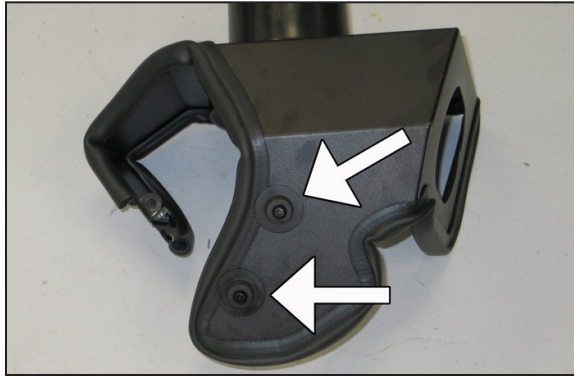

15. Install the factory mounting grommets to the two mounting posts installed on the K&N® heat shield assembly as shown.

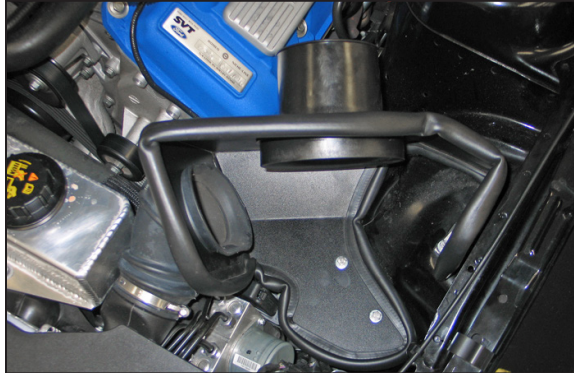

16. Install the heat shield assembly into the vehicle so the mounting bracket aligns with the factory airbox mounting location and the mounting grommets set into the mounting holes. Insert the fresh air duct into the heat shield.

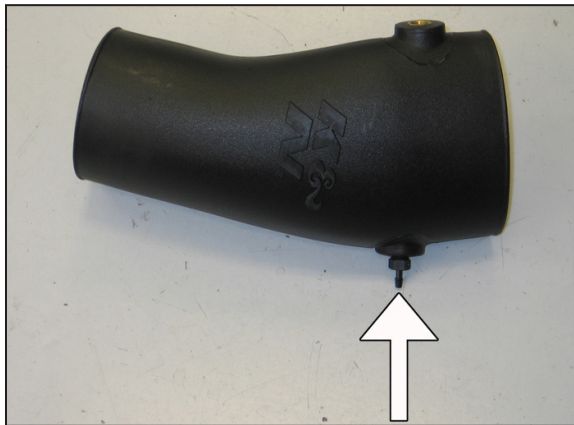

17. Install the provided 3/16" vacuum fitting into the K&N® intake tube as shown.

NOTE: Plastic NPT fittings are easy to cross thread. Install the vent fitting "hand" tight, then turn it two complete turns with a wrench.



18. Install the quick disconnect fitting into the K&N® intake tube as shown.

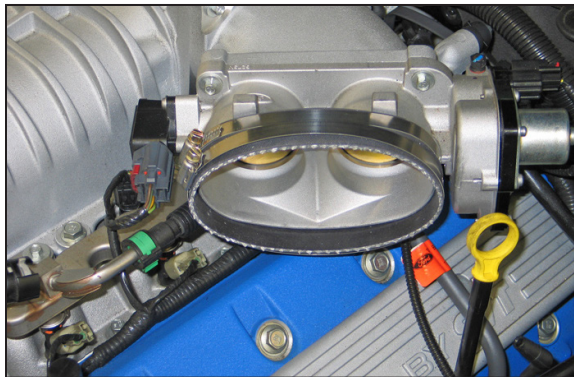

19. Install the provided silicone hose (08627) onto the throttle body and secure with the provided hose clamp.



20. Install the provided silicone hose (08695) onto the K&N® intake tube, slide the hose all the way onto the K&N® intake tube; do not tighten at this time.



21. Install the K&N® intake tube into the silicone hose at the throttle body and align with the mass air sensor housing. Slide the silicone hose down the K&N® intake tube onto the mass air sensor housing. Align the tube for best fit and then secure with the provided hose clamps.

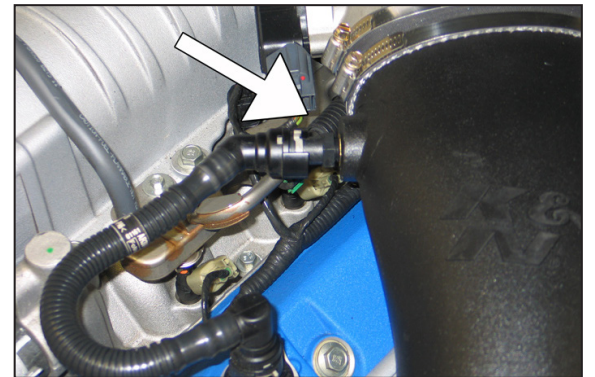

22. Connect the crankcase vent line to the quick disconnect fitting installed into the K&N® intake tube.



23. Connect the vent line to the 3/16" fitting installed into the K&N® intake tube.

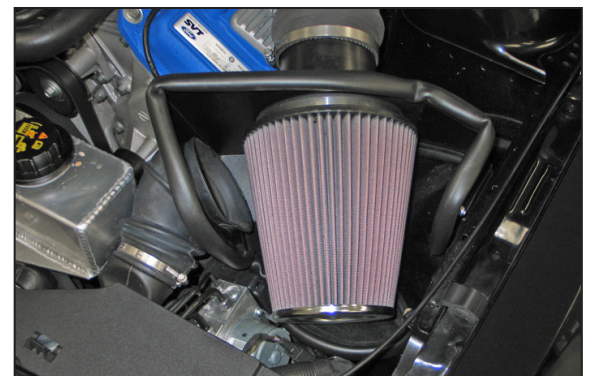

24. Install the K&N® air filter and secure with the provided hose clamp.
NOTE: Drycharger® air filter wrap; part # RF-1020DK is available to purchase separately. To learn more about Drycharger® filter wraps or look up color availability please visit <http://www.knfilters.com>.

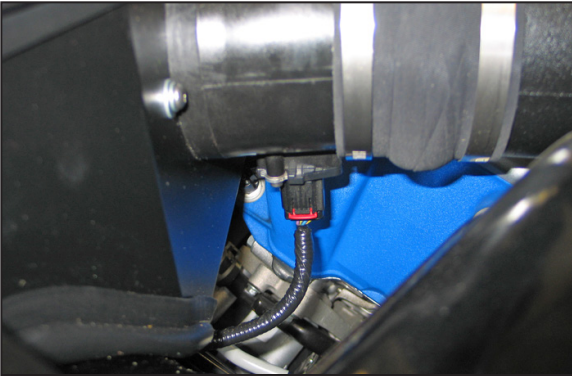

25. Reconnect the mass air sensor electrical connection.



26. Reconnect the vehicle's negative battery cable. Double check to make sure everything is tight and properly positioned before starting the vehicle.

27. It will be necessary for all K&N® high flow intake systems to be checked periodically for realignment, clearance and tightening of all connections. Failure to follow the above instructions or proper maintenance may void warranty.

ROAD TESTING:

1. Start the engine with the transmission in neutral or park, and the parking brake engaged. Listen for air leaks or odd noises. For air leaks secure hoses and connections. For odd noises, find cause and repair before proceeding. This kit will function identically to the factory system except for being louder and much more responsive.
2. Test drive the vehicle. Listen for odd noises or rattles and fix as necessary.
3. If road test is fine, you can now enjoy the added power and performance from your kit.
4. K&N Engineering, Inc., suggests checking the air filter element periodically for excessive dirt build-up. When the element becomes covered in dirt (or once a year), service it according to the instructions on the Recharger® service kit, part number 99-5050 or 99-5000.

NOT LEGAL FOR SALE OR USE ON ANY POLLUTION CONTROLLED MOTOR VEHICLE IN CALIFORNIA OR STATES ADOPTING CALIFORNIA EMISSION PROCEDURES.

See knfilters.com for CARB status on each part for a specific vehicle