



AIRCHARGER®

HIGH-FLOW INTAKE KITS

NOT LEGAL FOR SALE OR USE ON ANY POLLUTION CONTROLLED MOTOR VEHICLE IN CALIFORNIA OR STATES ADOPTING CALIFORNIA EMISSION PROCEDURES.

See knfilters.com for CARB status on each part for a specific vehicle

INSTALLATION INSTRUCTIONS

63-3068
CADILLAC
2006-07 CTS V
V8-6.0L

TOOLS NEEDED:

- 5/8" wrench
- 4mm Allen Wrench
- 10mm Socket
- 10mm Wrench
- Flat Blade Screwdriver
- Extension
- Ratchet

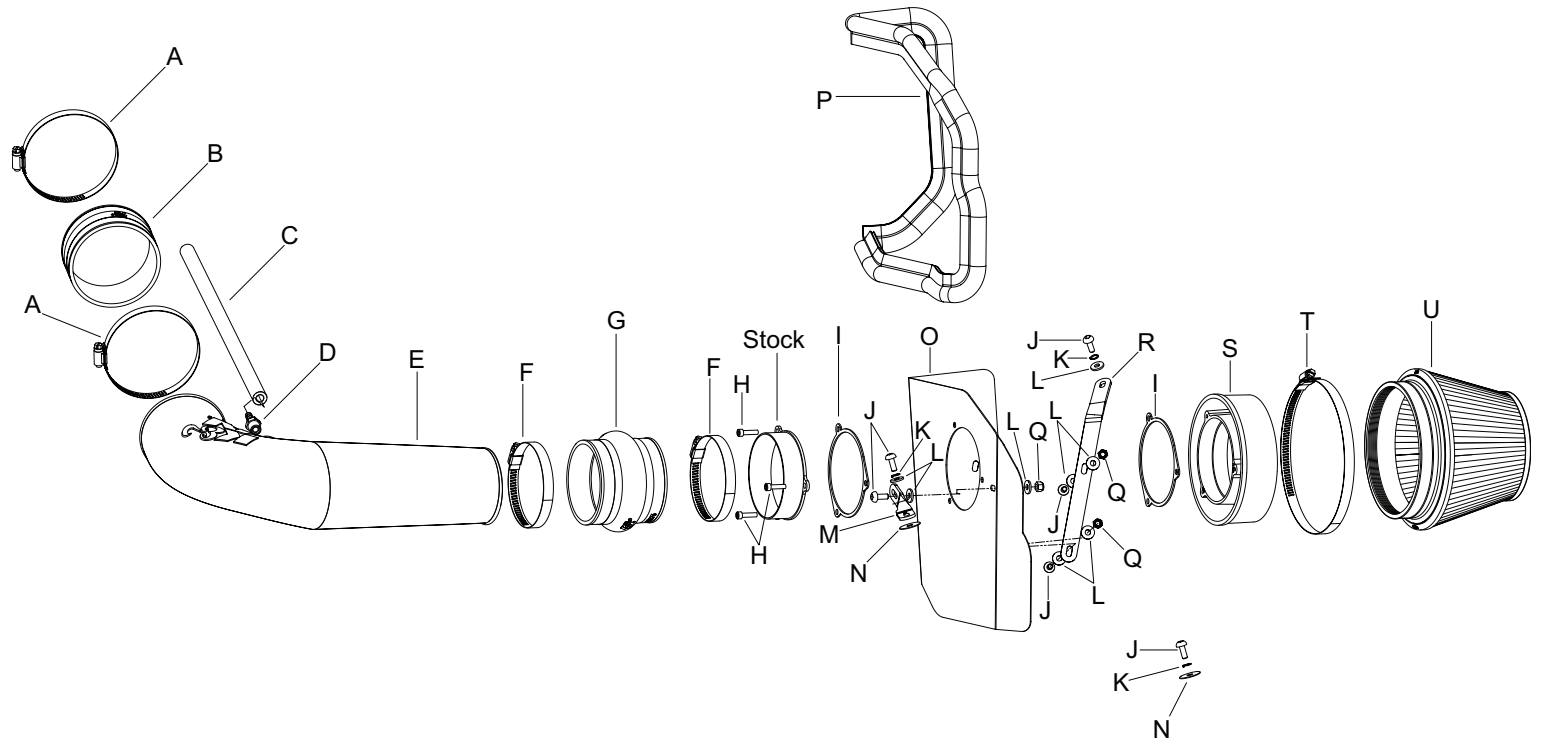

PARTS LIST:

Description	Qty.	Part #
A Hose Clamp #64 Stainless	2	08645
B Hose; 4" ID X 2" L Molded	1	08625
C Hose; 3/8" ID X 17" L	1	08404
D Vent; Strt, 3/8"Hose, 1/4"NPT, Plas.	1	08047
E Intake Tube	1	087053
F Hose Clamp #60 Stainless	2	08628
G Hose; 3-5/8" ID X 3-3/8" L Hump Molded	1	08176
H Bolt; 5MM-.80 X 20mm, Allen ZN	3	08320
I Gasket; 99 Silverado, 1/16"Neoprene	2	09033
J Bolt; M6 X 1.00 X 16mm , BtnHd., SS	6	07730
K Washer; 1/4" Lock, ZN	3	08198
L Washer; 1/4"ID X 5/8"OD - SAE	8	08275
M Bracket; Twist, Mild STL. FB/PC	1	010127
N Washer; 1"D X 1/4 Hole Fender	2	08160
O Heat Shield	1	07666
P Edge Trim (48")	1	102485
Q Nut; 6mm Nylock, Hexhead, SS	3	07512
R Bracket; Angle, Mild STL. FB/PC	1	010126
S Adaptor; FB/PC #240	1	08783
T Hose Clamp #104	1	08697
U Air Filter	1	RC-2960

NOTE: FAILURE TO FOLLOW INSTALLATION INSTRUCTIONS AND NOT USING THE PROVIDED HARDWARE MAY DAMAGE THE INTAKE TUBE, THROTTLE BODY AND ENGINE.

TO START:

1. Turn off the ignition and disconnect the negative battery cable.
NOTE: Disconnecting the negative battery cable erases pre-programmed electronic memories. Write down all memory settings before disconnecting the negative battery cable. Some radios will require an anti-theft coded to be entered after the battery is reconnected. The anti-theft code is typically supplied with your owner's manual. In the event your vehicles' anti-theft code cannot be recovered, contact an authorized dealership to obtain your vehicles anti-theft code.

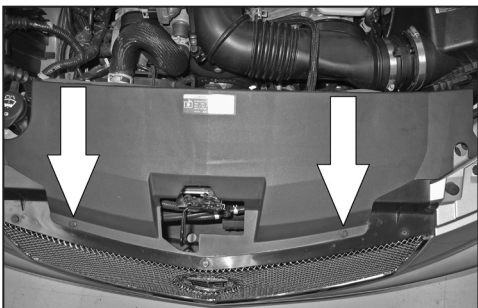

2. Release the two radiator cover retaining pins.

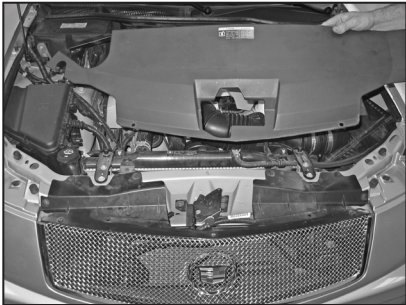

3. Remove the radiator cover from the vehicle.

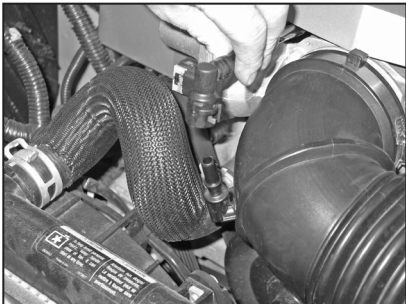

4. Release the crank case vent clip and then disconnect the crank case vent hose from the intake tube as shown.



5. Loosen the hose clamps which secure the intake tube to the throttle body and air filter, then remove the intake tube from the vehicle as shown.



6. Lift up the engine cover to dislodge it from the mounting grommets and then remove the cover from the vehicle.



7. Remove the factory crank case vent hose from the valve cover.

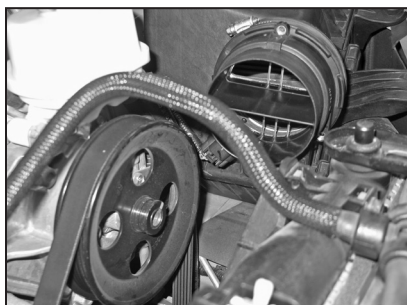

8. Disconnect the mass air sensor electrical connection.

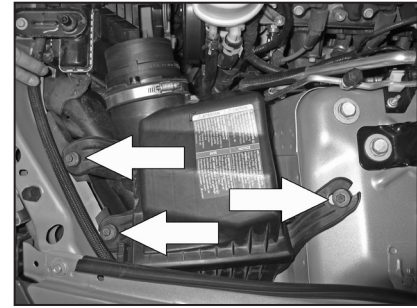

9. Remove the three bolts which retain the air box.



10. Remove the air box assembly from the vehicle.
NOTE: K&N Engineering, Inc., recommends that customers do not discard factory air intake.



11. Loosen the hose clamp which secures the mass air sensor to the air box and then remove mass air sensor from the air box.



12. Secure the splash shield to the core support with the hardware provided.

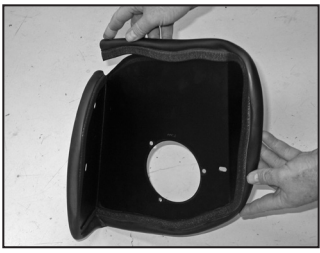

13. Install the edge trim onto the heat shield as shown.

NOTE: Some trimming of the edge trim will be necessary.

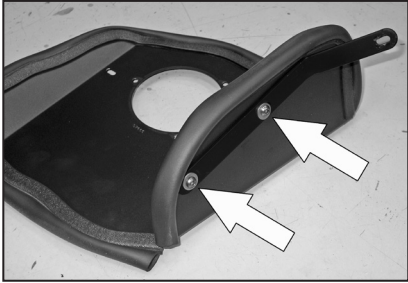

14. Install the heat shield mounting bracket (010126) onto the heat shield as shown using the provided hardware.

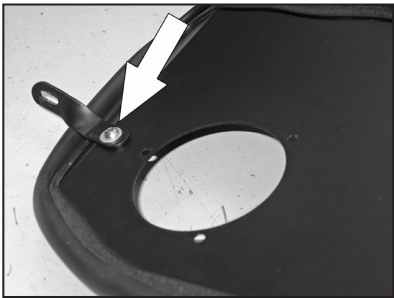

15. Install the heat shield mounting bracket (010127) onto the heat shield as shown using the provided hardware.



16. Assemble the mass air sensor and filter adapter with the provided gaskets onto the heat shield as shown using the provided hardware.

NOTE: Be sure to place one of the two gaskets on each side of the heat shield.



17. Install the K&N® air filter onto the filter adapter and secure with the provided hose clamp.

NOTE: Drycharger® air filter wrap; part number 22-8049DK is available to purchase separately. To learn more about Drycharger® filter wraps or look up color availability please visit <http://www.knfilters.com>®.

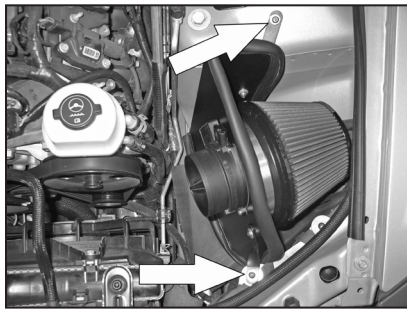

18. Install the heat shield assembly into the engine compartment and secure with the provided hardware.

NOTE: Be sure to place the fender washer under the mounting bracket to retain the splash guard.



19. Install the silicone hose (08625) onto the throttle body and secure with the provided hose clamp.

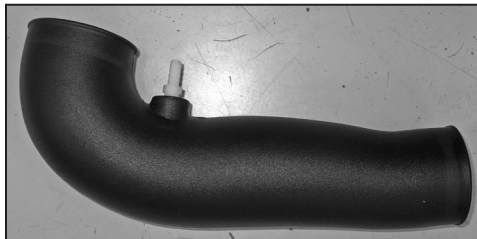

20. Install the crank case vent fitting into the K&N® intake tube as shown.

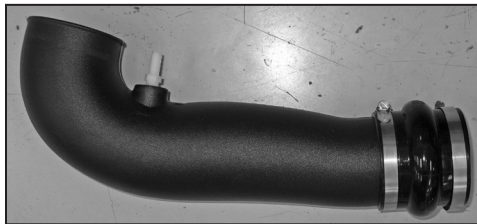

21. Install the silicone hose (08176) onto the K&N® intake tube and secure with the provided hose clamp.



22. Install the K&N® intake tube onto the mass air sensor and then into the silicone hose on the throttle body. Secure the intake tube with the provided hose clamps.

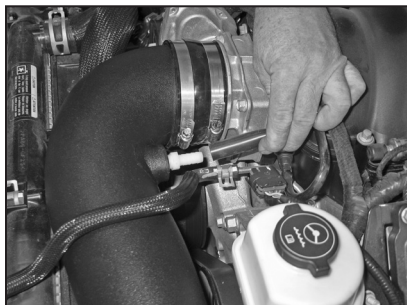

23. Install the provided crank case vent hose onto the valve cover and then connect the open end to the vent fitting on the K&N® intake tube.

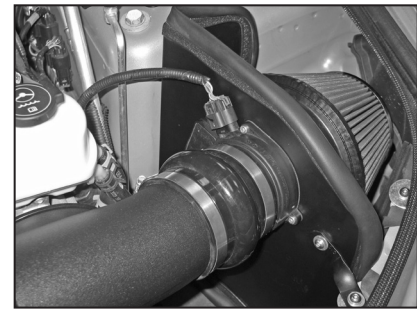

24. Reconnect the mass air sensor electrical connection.



25. Reinstall the engine cover and radiator cover. Secure the radiator cover with the factory retainers.



26. Reconnect the vehicle's negative battery cable. Double check to make sure everything is tight and properly positioned before starting the vehicle.

27. It will be necessary for all K&N® high flow intake systems to be checked periodically for realignment, clearance and tightening of all connections. Failure to follow the above instructions or proper maintenance may void warranty.

ROAD TESTING:

1. Start the engine with the transmission in neutral or park, and the parking brake engaged. Listen for air leaks or odd noises. For air leaks secure hoses and connections. For odd noises, find cause and repair before proceeding. This kit will function identically to the factory system except for being louder and much more responsive.

2. Test drive the vehicle. Listen for odd noises or rattles and fix as necessary.

3. If road test is fine, you can now enjoy the added power and performance from your kit.

4. K&N Engineering, Inc., requires cleaning the intake system's air filter element every 100,000 miles. When used in dusty or off-road environments, our filters will require cleaning more often. We recommend that you visually inspect your filter once every 25,000 miles to determine if the screen is still visible. When the screen is no longer visible some place on the filter element, it is time to clean it. To clean and re-oil, purchase our filter Recharger® service kit, part number 99-5050 or 99-5000 and follow the easy instructions.

NOT LEGAL FOR SALE OR USE ON ANY POLLUTION CONTROLLED MOTOR VEHICLE IN CALIFORNIA OR STATES ADOPTING CALIFORNIA EMISSION PROCEDURES.

See knfilters.com for CARB status on each part for a specific vehicle