



AIRCHARGER[®]

HIGH-FLOW INTAKE KITS

LEGAL IN CALIFORNIA ONLY FOR RACING VEHICLES WHICH MAY NEVER BE USED, REGISTERED OR LICENSED FOR USE UPON A HIGHWAY.

See knifilters.com for CARB status on each part for a specific vehicle

INSTALLATION INSTRUCTIONS

63-9022
TOYOTA / LEXUS
2003-04 4RUNNER
2003-04 GX470
V8-4.7L

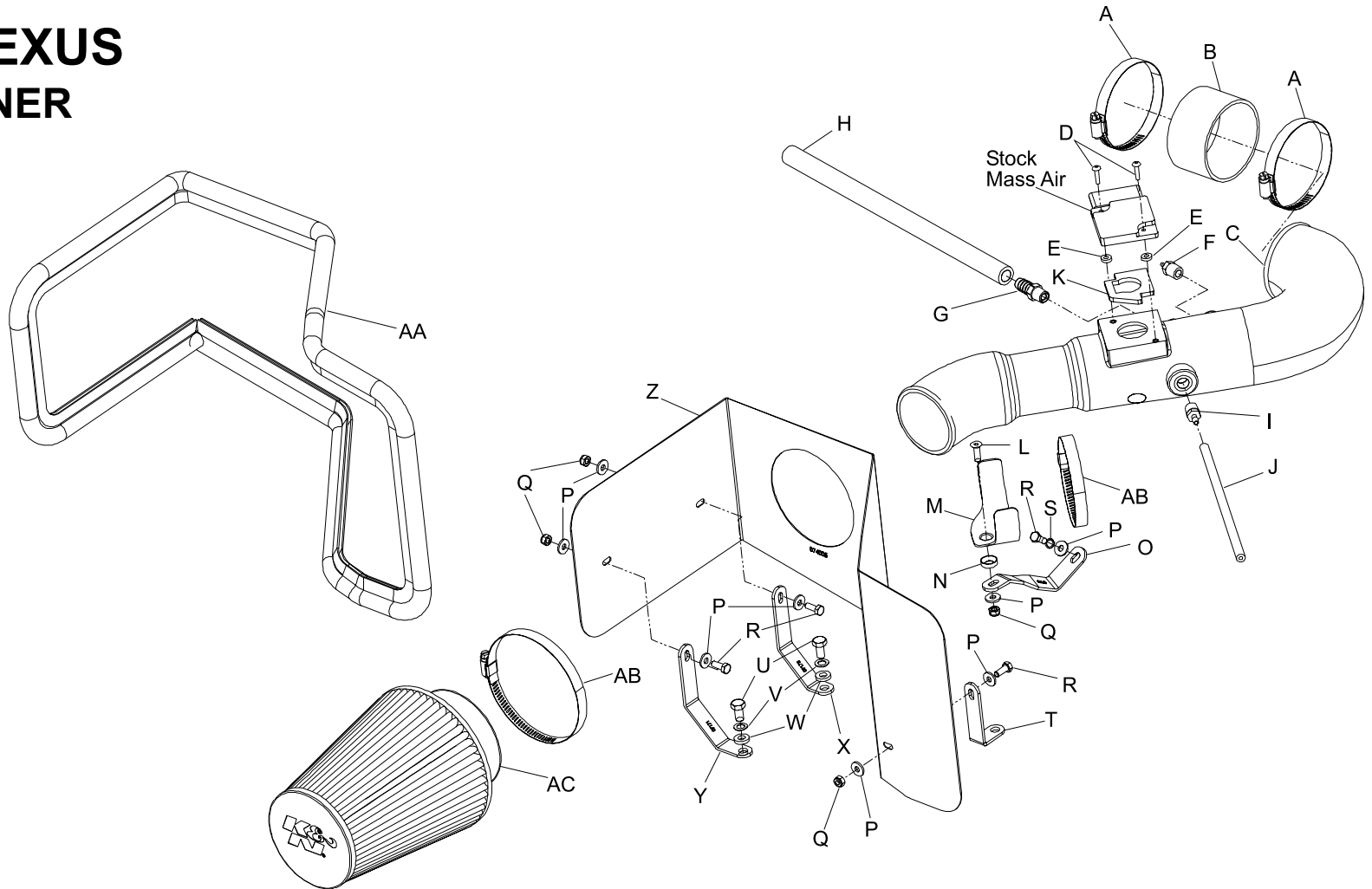

PARTS LIST:

Description	Qty.	Part #	Description	Qty.	Part #	Description	Qty.	Part #	Description	Qty.	Part #
A HOSE CLAMP; #48	2	08601	I VENT; 1/4"NPT, 3/16 BARB	1	080021	Q NUT; 6MM NYLOCK	4	07553	Y BRACKET; "U"	1	07171A
B HOSE; 3.25"ID X 2"L	1	08690	J HOSE; 5/32"ID X 9"L	1	08139	R BOLT; M6-1.00 X 16MM	4	07703	Z HEAT SHIELD	1	074005
C INTAKE TUBE; (DA)	1	087095A	K GASKET; 3/16" PORON	1	09026	S WASHER; 1/4" LOCK	1	08198	AA EDGE TRIM; 75"L	1	102460
D SCREW; M4-.7 X 16MM	2	07793	L BOLT; M6-1.00 X 20MM	1	08376	T BRACKET; "L"	1	070632A	AB HOSE CLAMP; #52	2	08610
E SPACER; .437"OD X .200"ID	2	06503	M BRACKET; SADDLE	1	078855	U BOLT; 8MM-1.25 X 16MM	2	07844	AC AIR FILTER	1	RU-5100
F VENT; STRT, 1/8 HOSE	1	08052	N WASHER; CONICAL	1	08180	V WASHER; 8MM SPRING	2	08239			
G VENT; STRT, 1/2" HOSE	1	080022	O BRACKET;	1	07173	W WASHER; 5/16"ID X 5/8"OD	2	08276			
H HOSE; 1/2"ID X 14"L	1	08402	P WASHER; 1/4"ID X 5/8"OD	8	08275	X BRACKET; "U"	1	07172			

NOTE: FAILURE TO FOLLOW INSTALLATION INSTRUCTIONS AND NOT USING THE PROVIDED HARDWARE MAY DAMAGE THE INTAKE TUBE, THROTTLE BODY AND ENGINE.

TO START:

1. Turn off the ignition and disconnect the negative battery cable.
NOTE: Disconnecting the negative battery cable erases pre-programmed electronic memories. Write down all memory settings before disconnecting the negative battery cable. Some radios will require an anti-theft code to be entered after the battery is reconnected. The anti-theft code is typically supplied with your owner's manual. In the event your vehicles' anti-theft code cannot be recovered, contact an authorized dealership to obtain your vehicles anti-theft code.



2. Loosen the two nuts that secure the throttle body cover then remove the throttle body cover.
Note: The cover may be different. On Lexus GX470 models, the passenger side engine compartment cover panel will also need to be removed.



3. Disconnect the mass air sensor electrical connection, then release wire loom from air box.

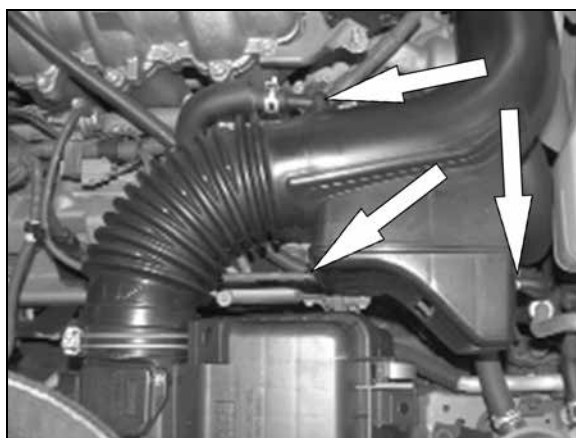

4. Remove the three vent lines from the air intake resonator as shown.



5. Loosen the hose clamp at the throttle body and air box, then remove intake tube from vehicle.



6. Remove the air box lid and filter to gain access to the three bolts that retain the air box to vehicle.



7. Remove the three bolts that retain the air box to vehicle, then remove the air box.

NOTE: K&N Engineering, Inc., recommends that customers do not discard factory air intake.

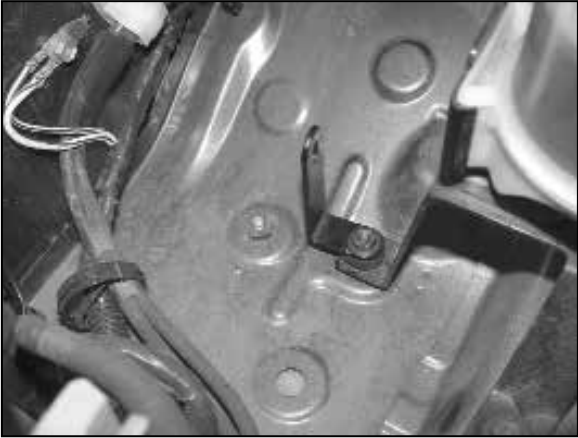

8. Remove the 12mm bolt that retains the power steering reserve to vehicle then mount the provided bracket (070632) onto the vehicle with the bolt that was removed.



9. Mount the two provided brackets onto the vehicle with the provided hardware.

NOTE: Bracket (07172) mounts closest to engine.



10. Install the edge trim onto the heat shield as shown. Trim if needed.



11. Install the heat shield onto the vehicle then secure to brackets with the provided hardware.

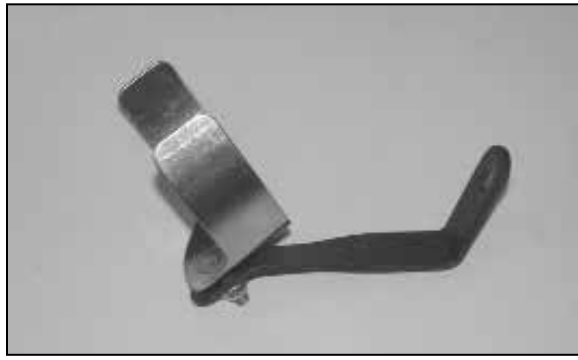

12. Assemble the saddle bracket assembly with the provided hardware as shown.



13. Install the saddle bracket assembly onto the threaded boss on the cam cover with the provided hardware as shown.



14. Install the provided silicone hose (08690) onto the throttle body with the provided hose clamp.



15. Remove the two screws that secure the mass air sensor to the air box lid, then remove the mass air sensor as shown.



16. Apply the gasket to the mass air sensor, sticky side down as shown.



17. Secure the mass air sensor to the K&N® intake tube using the provided screws and spacers as shown.



18. Assemble the vent fittings onto the K&N® intake tube as shown.

NOTE: Plastic NPT fittings are easy to cross thread. Install the vent fitting "hand" tight, then turn it two complete turns with a wrench.



19. Install the K&N® intake tube onto the throttle body and align with the saddle bracket.



20. Secure the K&N® intake tube to the saddle bracket with the provided hose clamps also tighten the hose clamp at the throttle body.



21. Install the provided silicone hose onto the K&N® intake tube and re-connect the one existing vent line as shown.



22. Install the K&N® air filter onto the intake tube as shown.

NOTE: Drycharger® air filter wrap; part #RC-5100DK is available to purchase separately. To learn more about Drycharger® filter wraps or look up color availability please visit <http://www.knfilters.com>.



23. Disconnect the ground strap that's attached to the mass air sensor wiring harness at the inner fender as shown.



24. Using the bolt that was removed in the previous step, connect the ground strap to wheel well as shown.



25. Reconnect the mass air sensor electrical connections.



26. Re-install the throttle body cover as shown.

Note: On Lexus GX470 models the Passenger side engine compartment panel will fit, light pressure will need to be applied down so the clips can be engaged. The cover can be left off if desired.



27. Reconnect the vehicle's negative battery cable. Double check to make sure everything is tight and properly positioned before starting the vehicle.

28. It will be necessary for all K&N® high flow intake systems to be checked periodically for realignment, clearance and tightening of all connections. Failure to follow the above instructions or proper maintenance may void warranty.

ROAD TESTING:

1. Start the engine with the transmission in neutral or park, and the parking brake engaged. Listen for air leaks or odd noises. For air leaks secure hoses and connections. For odd noises, find cause and repair before proceeding. This kit will function identically to the factory system except for being louder and much more responsive.

2. Test drive the vehicle. Listen for odd noises or rattles and fix as necessary.

3. If road test is fine, you can now enjoy the added power and performance from your kit.

4. K&N Engineering, Inc., requires cleaning the intake system's air filter element every 100,000 miles. When used in dusty or off-road environments, our filters will require cleaning more often. We recommend that you visually inspect your filter once every 25,000 miles to determine if the screen is still visible. When the screen is no longer visible some place on the filter element, it is time to clean it. To clean and re-oil, purchase our filter Recharger® service kit, part number 99-5050 or 99-5000 and follow the easy instructions.

LEGAL IN CALIFORNIA ONLY FOR RACING VEHICLES WHICH MAY NEVER BE USED, REGISTERED OR LICENSED FOR USE UPON A HIGHWAY.

See knfilters.com for CARB status on each part for a specific vehicle