



TYPHOON INTAKE SYSTEMS

INTAKE SYSTEMS FOR VEHICLES LISTED ARE 50 STATE LEGAL. SEE KNFILTERS.COM FOR CARB STATUS ON EACH PART FOR A SPECIFIC VEHICLE.

INSTALLATION INSTRUCTIONS

69-2551TS CHRYSLER 2015-17 200 L4-2.4L

NOTE: EXCLUDING LEV3 SULEV30
2015-17 TEST GROUPS FCRXJ02.4CP0,
GCRXJ02.4CP0 and HCRXJ02.4CP0

TOOLS NEEDED:

- flat blade screw driver
- ratchet
- extension
- 10mm socket
- 3mm allen key

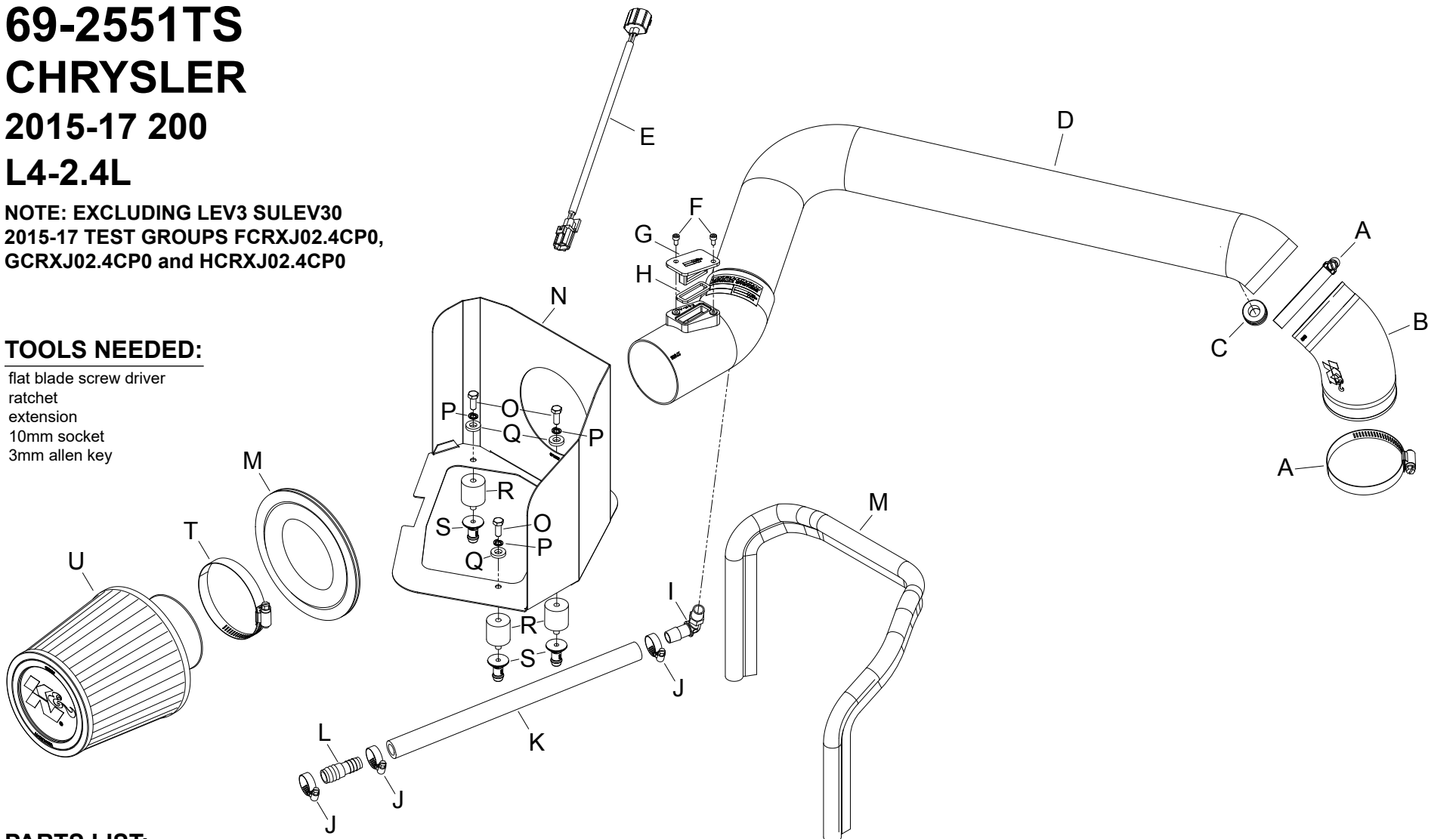

PARTS LIST:

Description	Qty.	Part #	Description	Qty.	Part #	Description	Qty.	Part #
A HOSE CLAMP #44 STAINLESS	2	08560	H GASKET; MASS AIR SENSOR	1	09076	O BOLT; 6MM-1.00 X 16MM, SS	3	07812
B HOSE; 2.75"ID ANGLED 30DEG	1	08489	I VENT; 90DEG, 1/2"HOSE, NPT	1	08110FK	P WASHER, M6 SPLIT LOCK ZINC	3	1-3025
C GROMMET; 1"OD, 1/2"ID, 1/2"	1	08064	J HOSE CLAMP #6 MINI	3	08407	Q WASHER; 1/4"ID X 5/8"OD	3	08275
D INTAKE TUBE	1	27635S	K HOSE; 1/2"ID X 12"L	1	087031	R STUD; RUBBER MOUNT, M6	3	02033
E EXTENSION HARNESS; IAT	1	21680	L HOSE MENDER; 1/2" TO 5/8"	1	08726	S MOUNT, PLASTIC AIRBOX	3	8-186-1
F BOLT; M4 - 0.7 8MM, A/H CAP	2	07733	M EDGE TRIM (46")	1	102487	T HOSE CLAMP #52	1	08610
G BLOCK OFF PLATE; MASS AIR	1	21508	N HEAT SHIELD	1	073207	U AIR FILTER	1	RU-4990

If you need any assistance please call 1-800-858-3333 to speak with a representative in our Customer Service Center before returning the product.

NOTE: FAILURE TO FOLLOW INSTALLATION INSTRUCTIONS AND NOT USING THE PROVIDED HARDWARE MAY DAMAGE THE INTAKE TUBE, THROTTLE BODY AND ENGINE.

TO START:

1. Turn off the ignition and disconnect the negative battery cable.
NOTE: Disconnecting the negative battery cable erases pre-programmed electronic memories. Write down all memory settings before disconnecting the negative battery cable. Some radios will require an anti-theft code to be entered after the battery is reconnected. The anti-theft code is typically supplied with your owner's manual. In the event your vehicles anti-theft code cannot be recovered, contact an authorized dealership to obtain your vehicles anti-theft code.



2. Lift up and remove the decorative engine cover.



3. Disconnect the inlet air temperature sensor electrical connection.



4. Remove the push pin that secures the resonator chamber onto the valve cover.



5. Disconnect the crank case vent hose from the factory intake tube.



6. Loosen the hose clamp that secures the intake tube to the air filter housing.



7. Loosen the hose clamp that secures the intake tube to the throttle body and then remove the intake tube from the vehicle.



8. Lift up and remove the factory air filter housing from the vehicle.

NOTE: Some models may be equipped with a humidity sensor, disconnect the electrical connection if equipped.

NOTE: K&N Engineering, Inc., recommends that customers do not discard factory air intake.



9. Install the three provided mounting pins onto the three rubber isolators as shown.



10. Install the mounting studs onto the heat shield using the provided hardware.

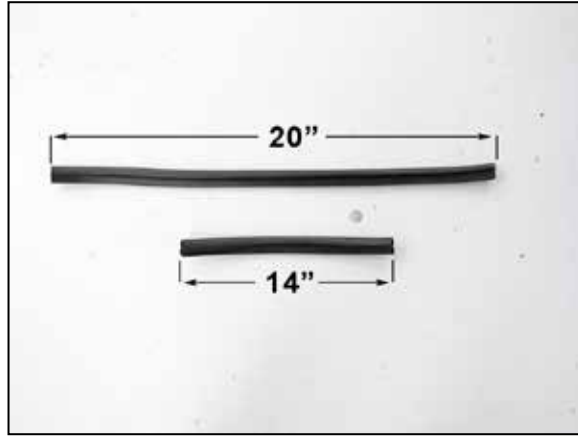

11. Cut the provided edge trim into two sections, one section will be 14" long and one section will be 20" long.



12. Install the edge trim onto the heat shield as shown.



13. Install the heat shield assembly onto the lower air filter housing mount so that the mounting studs insert into the factory grommets.



14. Install the K&N® air filter through the heat shield as shown.



15. On vehicles that are not equipped with a mass air sensor, install the provided gasket onto the mass air sensor mount block off as shown and then install the block off onto the K&N® intake tube.



16. If the vehicle is equipped with a mass air sensor, remove the sensor from the factory housing and install it into the K&N® intake tube using the provided hardware.



17. Install the provided 90° npt fitting into the K&N® intake tube as shown.

NOTE: Plastic NPT fittings are easy to cross thread. Install the vent fitting "hand" tight, then turn it two complete turns with a wrench.



18. Install the provided hose mender into the provided crank case vent hose and secure with the provided clamp.



19. Install the crank case vent hose assembly onto the 90° fitting installed into the K&N® intake tube.



20. Install the provided grommet into the K&N® intake tube as shown.



21. Remove the inlet air temperature sensor from the factory intake tube.

NOTE: Use caution when removing the inlet air temperature sensor as it is very fragile.



22. Remove the O-Ring from the sensor and then install the sensor into the grommet installed into the K&N intake tube.



23. Install the extension harness onto the inlet air temperature sensor.



25. Install the K&N® intake tube into the K&N® air filter and then connect the coupling hose to the throttle body. Adjust the tube and hose for best fit and then secure with the provided hose clamps.



26. Connect the inlet air temperature sensor extension harness to the factory harness.



27. Connect the crank case vent hose and secure with the provided hose clamp. If the vehicle is equipped with a mass air sensor connect the electrical connection.



28. Reinstall the decorative engine cover.



29. Reconnect the vehicle's negative battery cable. Double check to make sure everything is tight and properly positioned before starting the vehicle.

30. The C.A.R.B. exemption sticker, (attached), must be visible under the hood so that an emissions inspector can see it when the vehicle is required to be tested for emissions. California requires testing every two years, other states may vary.

31. It will be necessary for all K&N® high flow intake systems to be checked periodically for realignment, clearance and tightening of all connections. Failure to follow the above instructions or proper maintenance may void warranty.

ROAD TESTING:

1. Start the engine with the transmission in neutral or park, and the parking brake engaged. Listen for air leaks or odd noises. For air leaks secure hoses and connections. For odd noises, find cause and repair before proceeding. This kit will function identically to the factory system except for being louder and much more responsive.

2. Test drive the vehicle. Listen for odd noises or rattles and fix as necessary.

3. If road test is fine, you can now enjoy the added power and performance from your kit.

4. K&N Engineering, Inc., requires cleaning the intake system's air filter element every 100,000 miles. When used in dusty or off-road environments, our filters will require cleaning more often. We recommend that you visually inspect your filter once every 25,000 miles to determine if the screen is still visible. When the screen is no longer visible some place on the filter element, it is time to clean it. To clean and re-oil, purchase our filter Recharger® service kit, part number 99-5050 or 99-5000 and follow the easy instructions.

INTAKE SYSTEMS FOR VEHICLES LISTED ARE 50 STATE LEGAL. SEE KNFILTERS.COM FOR CARB STATUS ON EACH PART FOR A SPECIFIC VEHICLE.